

eyecon™ 9420

Avery Weigh-Tronix



Revolutionary Tabletop Automation

Prescription Validation,
Counting and Filling System

eyecon™ 9420

The next generation pharmacy automation system

Eyecon continues to become the preferred choice of pharmacies looking to improve their prescription filling process. Eyecon 9420 builds on the revolutionary technology of the original Eyecon machine, with enhanced features that take the system to the next level.

Filling automation improves Rx accuracy, improving inventory control with an average pharmacy saving thousands of dollars per year.

The Eyecon 9420 uses a unique Visual Counting System™ that is up to 76% faster and significantly more accurate than manual counting. It helps reduce tedium and stress while allowing employees to spend more time with customers. Your customers will benefit from improved customer service and Rx accuracy.

The updated Eyecon 9420 widescreen display presents more information in a single view and the touchscreen delivers enhanced brightness, touch accuracy and supports multi-touch for pinch and zoom.

A new i3 processor supports multi-tasking and together with 8GB of RAM and a 128GB SSD, provides improved responsiveness, especially with higher counts of smaller pills.

Satisfied Eyecon Owners

"I have three pharmacies and an Eyecon in each location. Everyone loves it and would not want to work without it. Hands down this is the best investment in technology that I have ever made."

"Eyecon has helped tremendously in our store. I would estimate the Eyecon frees me up about half an hour a day extra to focus on my business and patients."

"It's nice to be able to go home and rest knowing that everything has been filled correctly!"



Visit our website to see a growing list of endorsements from pharmacists across the country:

www.eyeconvpc.com/endorsements

How Eyecon works

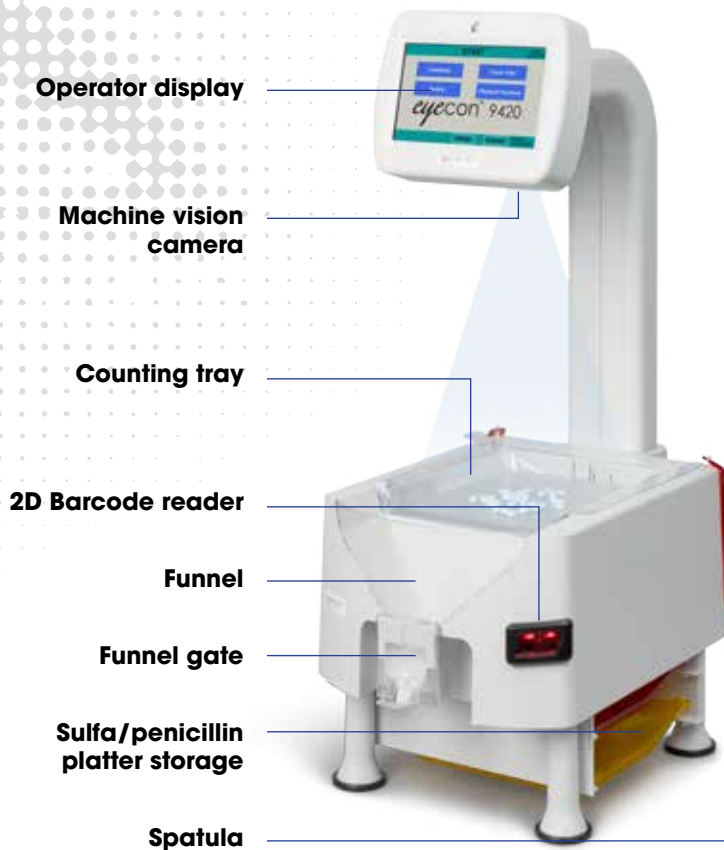

Eyecon is a unique machine vision counting system. A camera mounted above the counting platter captures photo images used to count pills five times per second.

- **Safety** - Validation mode ensures patient safety with proper dispensing. Separate sulfa and penicillin platters prevent cross-contamination.
- **Speed** - Counts poured pills in 200 ms, updating pill count up to 5 times per second.
- **Accuracy** - Field-tested approaching 100%.
- **Quality** - Recognizes and identifies foreign matter and tablet fragments of dissimilar size and shape.
- **Confidence** - The open design allows quick and easy inspection of the medication being dispensed.
- **Versatility** - Counts all sizes and shapes of capsules and tablets. Can also be used for validation and inventory of ointments, creams, solutions and pre-packs.
- **Longevity** - Regular updates to drug database and user interface.
- **Cleaning** - No hidden compartments or disassembly required.
- **Photographic Documentation** - An annotated pill tray photograph with individually numbered pills is saved for every Rx transaction.
- **On-Screen Reports** - Various transaction reports can be viewed on the Eyecon's screen and exported when needed. The pill tray photo(s) associated with any selected transaction can be viewed on the Eyecon screen or any network computer in your pharmacy.
- **Interface** - Connect Eyecon to your pharmacy management software (PMS) to make Eyecon aware of all the prescriptions that are waiting to be filled and allow Eyecon to send the fill results back to your PMS, which can advance the Rx to pharmacist verification and record the Drug Number and quantity filled, the time/date of fill, and other details.

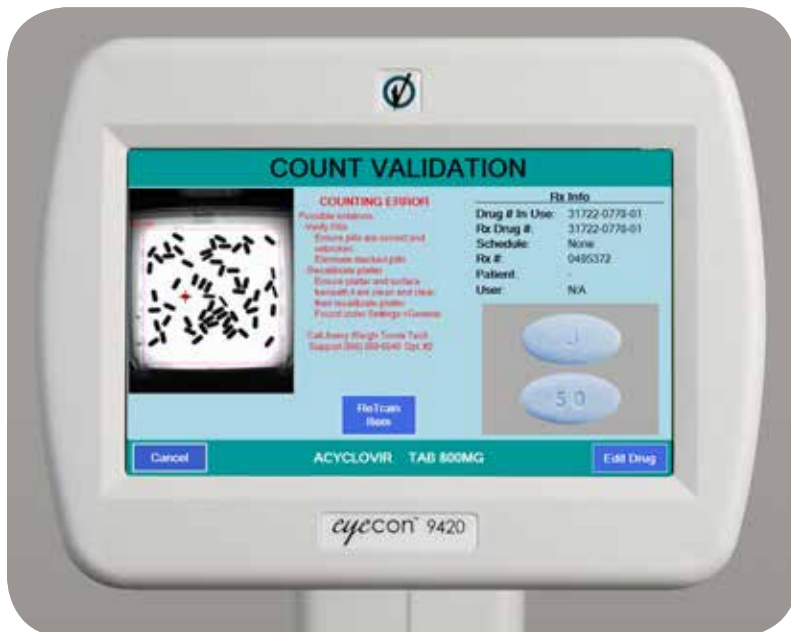

Counting Errors - If Eyecon detects objects on the tray that are sufficiently different in size or shape than the pills being counted, a counting error screen is shown. A pill tray photo displays the object(s) in question identified by a red plus sign.

Rx validation mode

Eyecon helps ensure that the medication dispensed into the vial matches what is on the prescription.



1

Scan Label - Scan barcode containing Drug Number, quantity, and Rx number. Or, with an interface, scan the existing barcode already on your vial label.



2

Scan Bottle - Scan barcode on stock bottle to validate that you've pulled the correct medication or be alerted to a generic substitution.



3

Verify - Eyecon will proceed to count mode if Rx label matches the stock bottle. Eyecon will display error if mismatch is detected.



4

Count Pills - Pour pills onto tray until display turns green, indicating match between required number of pills and number of pills on the tray (see below).



5

Dispense - Press Finish button to record the transaction, then lift platter to slide pills into funnel.



6

Fill Vial - Use vial to lift funnel gate and allow pills to flow into vial.



Yellow indicates under count.



Green indicates correct count.



Red indicates over count.

Counting features



Alert Screens

When various situations occur, an alert screen is displayed, notifying the operator of the issue.

- **Wrong Fill Quantity Warning** - When finishing a fill in validation mode, if the displayed quantity does not match the prescription quantity, a warning is displayed allowing the operator to correct the fill amount. This prevents a common cause of fill errors when the operator correctly counts the incorrect quantity.
- **Partial Fills** - Eyecon tracks partially filled prescriptions. When stock is replenished and the Rx label barcode is scanned, a notice of the prior partial fill is provided to the operator. A tray photo is saved for each dispensed amount.
- **Generic Substitutions** - Allows the operator to dispense a generic equivalent of the Drug Number that was specified in the data sent to Eyecon. An alert screen is shown allowing the operator to accept or refuse the substitution. Alternatively, generic substitutions can be automatically rejected, if that is your preference.
- **Double-Count and Back-Count** - Eyecon can be configured to either double-count your Rx fills and/or back-count the remainder in your stock bottle after filling an Rx, based on the DEA classification level as compared to DEA level specified in the Eyecon setup for each feature.

Annotated Tray Photo

Eyecon is the first vision-based validation and pill counting system that also saves a photo of every transaction. If a count is questioned, the photo can be viewed and/or printed. Every pill is sequentially numbered and all of the prescription data is annotated onto the photo as shown in the sample below.

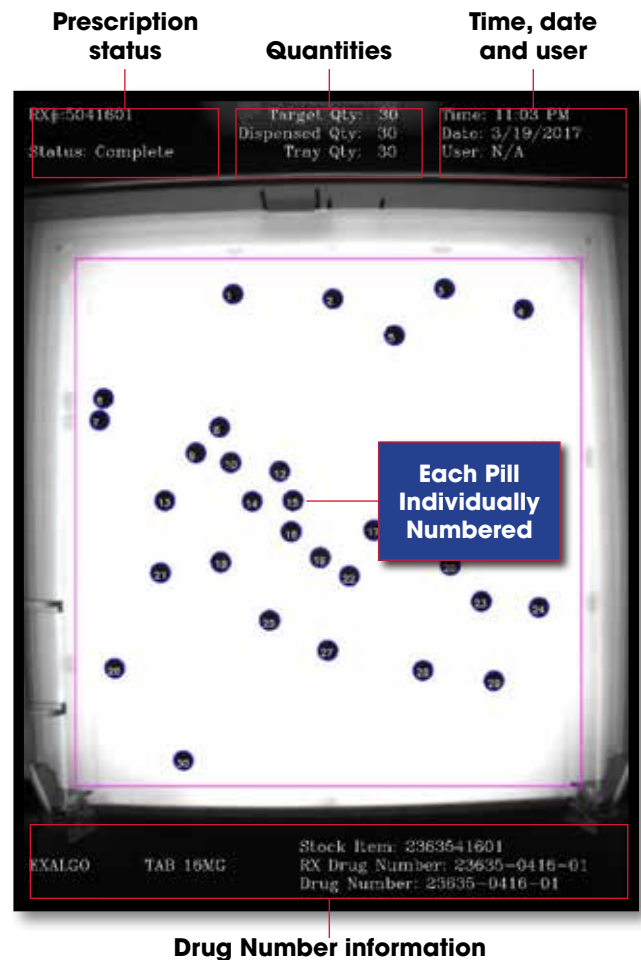

Eyecon in Action

Get a sense of the true speed of Eyecon counting by viewing a testimonial video. The video shows an experienced operator using Eyecon to fill prescriptions, as well as an interview with the pharmacy owner.

Visit: www.youtube.com/EyeconVPC

Physical inventory mode

Use Eyecon to periodically perform a physical inventory or cycle count. Using a similar process as prescription filling, Eyecon quickly counts all medications within the pharmacy and records the results in a database.

- 1. Scan the stock bottle at Eyecon.**
- 2a. For full bottles, blister packs, liquids, or other non-countables, press Unit of Use to display the full package quantity, type in the number of full containers.** Press the Ok button to accept or edit as necessary.
- 2b. For discrete pills, pour the pills onto the tray.** Eyecon counts the pills just as if it were counting them to fill a prescription. If the stock bottle contains more than what the tray will hold, press Add to Total, and then empty the tray and resume counting.
- 3. Store records.** Press the Finish button to store the results or scan the user's barcode to identify who performed the count.
- 4. Download results.** After counting inventory, go to the settings menu and press the Download Inventory button to convert data into a format suitable for importing.



- Reduce carrying costs by increasing inventory turns and eliminating excess inventory.
- Free up staff to conduct more patient consultations.
- Reduce inventory variances and conduct fewer physical inventories due to increased prescription filling accuracy.
- Significantly reduce time spent conducting physical inventories.
- Improve employee morale by eliminating monotony of manual pill counting.

Unit of use

Unit of Use allows the operator to dispense a full bottle or manually entered quantity and record that in the Report Database. Also allows the combining of Eyecon counted pills with the full bottle or manually entered quantity.

Within inventory mode, Unit of Use allows multiple full bottles to be scanned and counted and then added to the quantity in the open bottles for faster, more accurate physical inventory counts.

Audit reports

Audit reports allow staff to analyze various aspects of prescriptions filled by Eyecon. Using filters, you can choose to view only C-II prescriptions, only fills of a specific Drug Number, all fills performed by specific user, all open partial-fills, or a summary of the types and number of prescriptions filled per day, and more.



Connectivity

Every Eyecon unit includes a built-in Ethernet interface to connect with a variety of pharmacy management software systems. After data entry, the prescription record is sent to the Eyecon where it is held until the associated Rx# or Order ID barcode is scanned. Next, the prescribed Drug Number is validated against the stock bottle to ensure the correct drug is dispensed.

After the prescription has been filled, data can be transmitted back to the pharmacy system to record data about the fill and advance the stage of the Rx in the pharmacy workflow.

Eyecon can also transfer a summary of all physical inventory counts to more quickly and accurately update perpetual counts in an inventory management system.

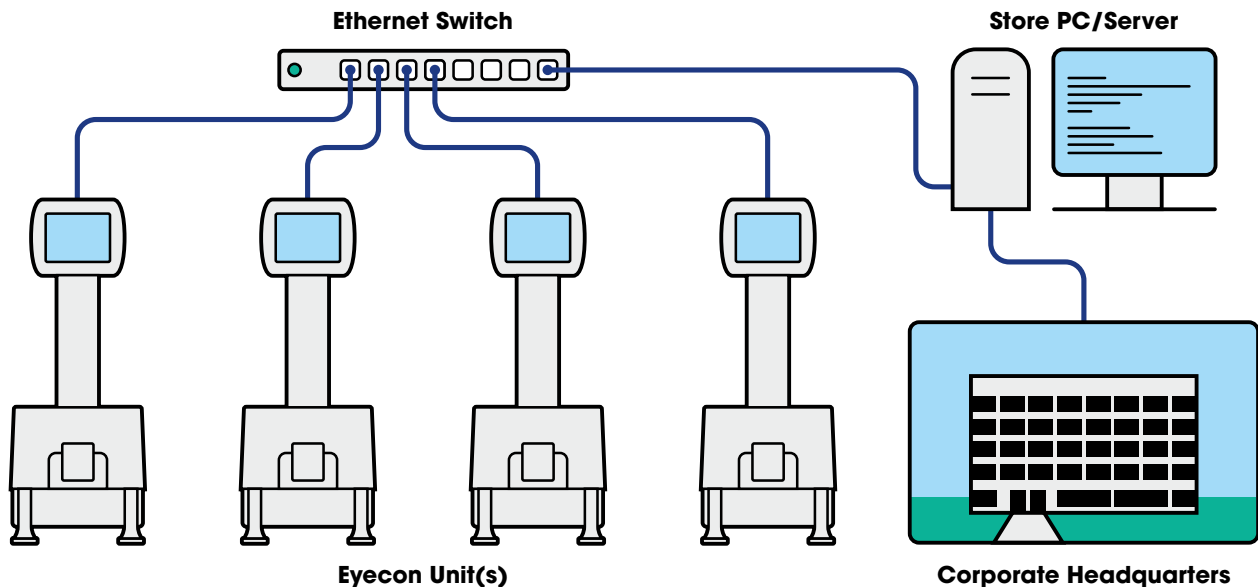

Specifications

- **Platter Surface Area:** 48" sq
- **Dimensions:** 28" H x 11" W x 17.5" D
- **Weight:** 18 lb (30 lb ship weight)
- **Widescreen Display:** 7" diagonal, 800 x 480 IPS LCD with LED backlighting
- **Integrated Barcode Scanner:** High performance 1D and 2D scan engine, motion tolerant and LED aiming dot
- **Warranty:** Two year limited
- Pill database updates provided regularly
- **Interfaces:** Over 20 pharmacy management software interfaces supported
- **USB:** Two USB 3.0 ports on the rear panel
- **Ethernet:** Gigabit LAN, RJ45 connection
- **Operating System:** Windows 10 Enterprise 2016 LTSB
- **Processor:** Intel® Core™ i3-5010U dual core
- **Storage:** 128 GB SSD
- **RAM:** 8 GB
- **Power:** 100-240 VAC, 47-60 Hz

- **Approvals:** UL/cUL approval for USA and Canada. UL file number E490213
- **US Patent #:** 8,682,047

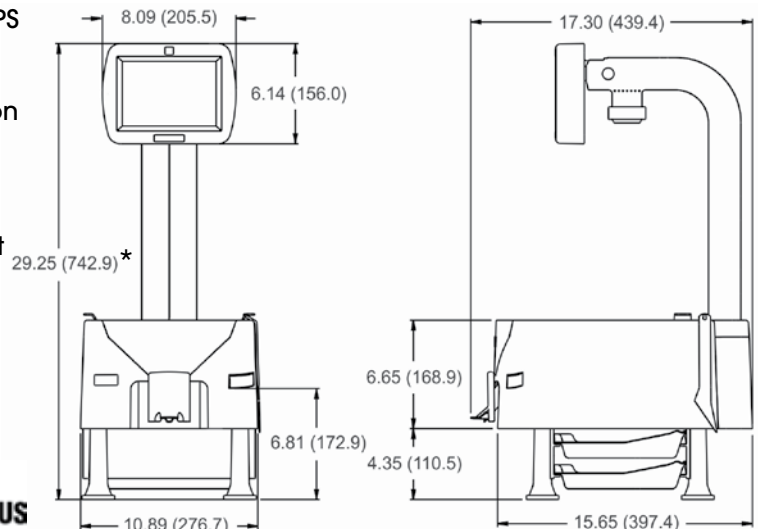

*maximum height when display is tilted upward



Return on investment

For most pharmacies, Eyecon pays for itself very quickly. For new pharmacies, Eyecon can delay the need to hire additional staff while providing the reassurance that your prescriptions are being filled correctly. Established pharmacies will discover increased throughput and accuracy.

- Eliminate over-dispensing and giving away pills.
- Fill prescriptions more quickly for reduced patient wait-time.
- Reduce customer frustration by avoiding under-fills.
- Ensure the correct drug is dispensed.
- Fewer partial-fills due to more accurate inventory.
- Reduce time spent on physical inventories.
- Reduce the number of nuisance claims of under-filled prescriptions for narcotics.
- Many false claimants cease attempts to obtain more pills once they are shown the annotated tray photo.
- Reduce legal liability through stock bottle validation and enhanced record-keeping.
- Save time and improve the accuracy of keeping track of partial fills.
- Produce reports for external auditors to document prescription filling activity.
- Be confident placing higher price and narcotic drugs into robotics by using Eyecon to double-count.

Testing shows Eyecon is fastest.

Prescription filling process was timed from stock bottle (start) to patient vial (finish). Process was performed five times to calculate average Rx fill time. Individual results may vary.



Pill Count	Product	Avg. Fill Time
30 pills	Eyecon®	13.6 sec
	GSE Model 664 Scale	15.6
	Competitive brand	17.1
	Hand counting	26.9
60 pills	Eyecon®	14.1 sec
	GSE Model 664 Scale	16.9
	Competitive brand	21.9
	Hand counting	47.7
90 pills	Eyecon®	15.9 sec
	GSE Model 664 Scale	17.0
	Competitive brand	26.8
	Hand counting	66.6

AUTHORIZED DISTRIBUTOR

eyecon™ 9420

www.eyeconvpc.com
Eyecon@awtxglobal.com
866-260-6540

Avery Weigh-Tronix

See our other non-pharmacy products at
www.averyweigh-tronix.com

Avery Weigh-Tronix is an ITW company



Visual Precision Counting™



Eyecon is part of Avery Weigh-Tronix. Avery Weigh-Tronix is a trademark of the Illinois Tool Works group of companies whose ultimate parent company is Illinois Tool Works Inc ("Illinois Tool Works"). Copyright © 2017 Illinois Tool Works. All rights reserved. This publication is issued to provide outline information only and may not be regarded as a representation relating to the products or services concerned. This publication was correct at the time of going to print, however Avery Weigh-Tronix reserves the right to alter without notice the specification, design, price or conditions of supply of any product or service at any time.

eyecon9420_L_501679.indd
5/17 AWT35-501679