

ZQ375
Checkweigher



User Instructions

Avery Weigh-Tronix is a trademark of the Illinois Tool Works group of companies whose ultimate parent company is Illinois Tool Works Inc (“Illinois Tool Works”). Copyright © 2016 Illinois Tool Works. All rights reserved.

No part of this publication may be reproduced by making a facsimile copy, by the making of a copy in three dimensions of a two-dimensional work and the making of a copy in two dimensions of a three-dimensional work, stored in any medium by electronic means, or transmitted in any form or by any means, including electronic, mechanical, broadcasting, recording or otherwise without the prior written consent of the copyright owner, under license, or as permitted by law.

This publication was correct at the time of going to print, however Avery Weigh-Tronix reserves the right to alter without notice the specification, design, price or conditions of supply of any product or service at any time.

Table of Contents

	<i>page</i>
Chapter 1 General information and warnings	7
About this manual	7
Text conventions	7
Special messages	7
Installation	8
Safe handling of equipment with batteries	8
Wet conditions	8
Routine maintenance	8
Cleaning the machine	9
ZQ375 cleaning process	9
Indicator	10
Cleaning the Rear of the Column	11
Base Cleaning	11
Training	11
Sharp objects	12
FCC and EMC declarations of compliance	12
United States	12
Canada	12
European Countries	12
Declarations of Conformity	13
Chapter 2 Introduction	15
Initial setup	15
Front panel	16
Annunciators	18
Tolerance entry procedure	19
Example: To increase a value of 0.002 to 0.125:	19
Numeric entry procedure	20
Example: To key in the number 507:	20
ID Entry Procedure	20
String index/character data entry	21
Powering up the ZQ375	23
Battery option	23
Installation	24
Proper charging of the ZQ-BAT	25
Charging the battery pack using the supplied wall charger	25
Charging the battery pack through a ZQ375 indicator:	26
Battery states indicated by LEDs	26
Checkweigher Operation on Battery Power	27
Light stack option	28
Light stack operation	28
Chapter 3 Checkweighing applications	29
Checkweighing terminology	29
Normal weighing procedures	31
Gross weighing	31
Tare/Net weighing	31
Using Pushbutton Tare (if enabled)	32
Using Preset Tare (if enabled)	32
Sim375 application	34
Checkweighing	34

Switching Between Checkweighing and Normal Weighing Mode	34
Setting a New Target Weight and Simple Checkweighing	34
View the High and Low Tolerances	35
Set New High and Low Tolerances	35
Mid375 application	36
SELECT key operation	36
Checkweighing	36
Negative checkweighing	37
Sample mode checkweighing	38
Sampling Method	38
Manual Target Weight Entry	38
View the Target Weight and Upper and Lower Tolerances	39
Set New Upper and Lower Tolerances	39
Transaction counter	40
Adv375 application	41
SELECT key operation	41
Checkweighing	41
Setting a New Target Weight and Checkweighing	42
Choosing a PLU and Checkweighing	42
View the Upper and Lower Tolerances	43
Set New Upper and Lower Tolerances	43
PLU Transaction counter	44
Statistical Package and Packrun	44
Printing the report:	44
Report Example:	45
X-Bar/R Program	45
Per375 application	46
Checkweighing	46
Setting a New Target Percentage and Checkweighing	46
Choosing a PLU and Checkweighing	47
View the Upper and Lower Tolerances	47
Set New Upper and Lower Tolerances	47
Grad375 application	49
Positive vs. negative grading	49
Grade classifying	49
Setting weight grades	49
Positive grading	50
Negative grading with autotare enabled	50
Negative grading with autotare disabled	51

Chapter 4 Menus	52
Accessing the menus	52
Menu annunciators	52
Exiting the menus	53
USER level menus	53
User menu	54
Time	54
Date	55
Site ID	56
Seal	56
About menu	57
Boot	57
Firm and App	58
Serial	58
Option	58
Enet	59
Dload	60

Audit menu	60
Counter	61
Print	61
Chapter 5 Error messages	62
PLU CSV file import error messages	63
Chapter 6 Communications	64
Default print formats	64
Chapter 7 Supervisor menu	66
Supervisor menu for Sim375 application	67
Setpoint	68
Annunciators	68
Inputs	69
Print	69
Reset	69
Check	70
Outputs	70
Output-gross zero band	71
Under segment division	71
Over segment division	71
Reset	72
Battery	72
Enable	72
Timeout	73
Supervisor menu for Mid375 application	74
Setpoint	75
Tare	75
Tare Register 1-10	75
Printing	76
Reset	76
Check	76
Outputs	77
Output-gross zero band	77
Under segment division	78
Over segment division	78
Print total	78
Total format	79
Clear total	79
Digits	79
Graph	80
Type	80
Auto Tare	81
Reset	81
Battery	81
Supervisor menu for Adv375 application	82
Setpoint	83
Tare	83
Check	83
Outputs	84
Outputs-gross zero band	84
Under segment division	84
Over segment division	85
Print total	85
Total format	86
Clear total	86
Digits	86

Graph	87
Stats	87
Packrun	88
Type	88
Auto Tare	88
Reset	89
PLU	89
Edit	89
Print	91
Import	91
Export	92
Reset	92
Battery	92
Supervisor menu for Per375 application	93
Setpoint	94
Tare	94
Check	94
PLU	94
Battery	94
Supervisor menu for the Grad375 application	95
Setpoint	96
Tare	96
Grading	96
Battery	98

1 General information and warnings

1.1 About this manual

This manual is divided into chapters by the chapter number and the large text at the top of a page. Subsections are labeled using the 1.1 and 1.1.1 convention. The names of the chapter and the next subsection level appear at the top of alternating pages of the manual to remind you of where you are in the manual. The manual name and page numbers appear at the bottom of the pages.

1.1.1 Text conventions

Key names are shown in **bold** and reflect the case of the key being described. If a key has dual functions, the name of the key is shown first followed by the function in parentheses and in bold, such as in these examples: **TARE(↑)**, **UNITS(→)**, etc.

Displayed messages appear in ***bold italic*** type and reflect the case of the displayed message.

1.1.2 Special messages

Examples of special messages you will see in this manual are defined below. The heading words have specific meanings to alert you to additional information or the relative level of hazard.



CAUTION!

This is a Caution symbol.

Cautions give information about procedures that, if not observed, could result in damage to equipment or corruption to and loss of data.



NOTE: This is a Note symbol. Notes give additional and important information, hints and tips that help you to use your product.

1.2 Installation



NO USER SERVICEABLE PARTS. REFER TO QUALIFIED SERVICE PERSONNEL FOR SERVICE.

1.2.1 Safe handling of equipment with batteries



CAUTION: *Danger of explosion if battery is incorrectly replaced. Replace only with the same or equivalent type recommended by the manufacturer. Dispose of used batteries according to the manufacturer's instructions.*

ATTENTION: *Il y a danger d'explosion s'il y a remplacement incorrect de la batterie, remplacer uniquement avec une batterie du même type ou d'un type équivalent recommandé par le constructeur. Mettre au rebut les batteries usagées conformément aux instructions du fabricant.*

1.2.2 Wet conditions

Under wet conditions, the plug must be connected to the final branch circuit via an appropriate socket / receptacle designed for washdown use.

Installations within the USA should use a cover that meets NEMA 3R specifications as required by the National Electrical Code under section 410-57. This allows the unit to be plugged in with a rain tight cover fitted over the plug.

Installations within Europe must use a socket which provides a minimum of IP56 protection to the plug / cable assembly. Care must be taken to make sure that the degree of protection provided by the socket is suitable for the environment.

1.3 Routine maintenance



IMPORTANT: *This equipment must be routinely checked for proper operation and calibration. Application and usage will determine the frequency of calibration required for safe operation.*

Always turn off the machine and isolate from the power supply before starting any routine maintenance to avoid the possibility of electric shock.

Before use in any NSF / ANSI 3-A food application this scale must be regularly inspected to guarantee cleanliness at all times.

Scale needs to be regularly inspected to guarantee there are no loose or missing nuts and that all bolt and knob threads are completely covered.

Check that the indicator and any battery or external OPTO22 relay box are secured correctly in place with the correct locking knob.

Check that the scale is set on a clean, flat, stable surface and levelled using the scale feet and bubble level found between the column and the base.

Feet can be adjusted by loosening the locking sleeve and rotating the foot in or out until the base becomes level.

Once level, the locking sleeve needs to be retightened with a spanner onto the base, guaranteeing there are no threads visible once locked in place. See the illustration below:

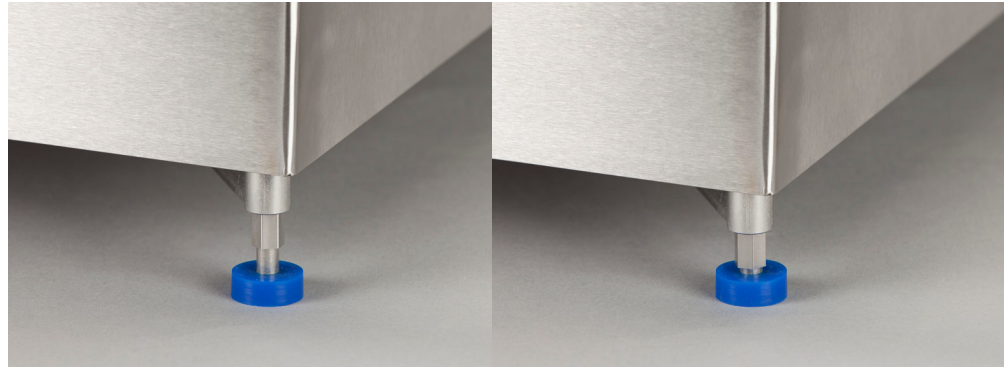

1.4 Cleaning the machine

1.4.1 ZQ375 cleaning process

The ZQ375 checkweigher has been designed for use within NSF / ANSI 3-A food applications.

It has minimum food trap areas to aid fast and efficient cleaning. All versions of the ZQ375 scale, indicator, remote battery pack and external opto22 relay box can be subjected to external high pressure cleaning to IP69K standards.

Bases marked with Model number **BSF** are suitable for high pressure cleaning externally and under the scale platter in line with IP69K standards.

Bases marked with model number **BSG** are only suitable for high pressure cleaning externally. Extra care has to be taken cleaning under the scale platter in line with IP65 / Nema4X standards.

1.4.2 Indicator



CAUTION: *It is essential that the power plug is kept in a safe dry area while cleaning is in progress.*

If external USB or Ethernet glands are installed in the indicator, it is essential these be sealed with water tight caps prior to cleaning or when the connectors are not in use.



1.4.3 Cleaning the Rear of the Column

For rigorous cleaning it is recommended that the external battery pack or external relay box, if installed, are removed to allow better access to the rear of the column while cleaning. Before high pressure washing the battery, protect the battery connector with the water tight cap supplied.



1.4.4 Base Cleaning

While cleaning, it is essential that the weighing platform and the support plate should be removed to allow full easy access into the base to aid the cleaning process and help to sanitize all areas of the base.

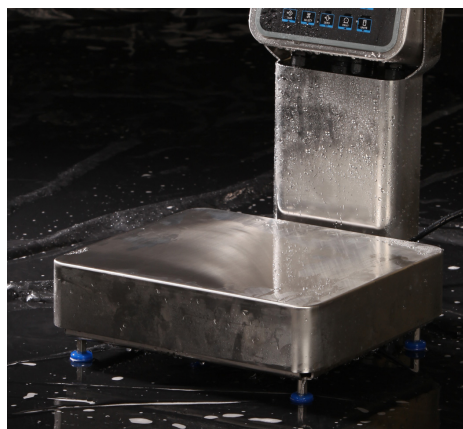

1.5 Training

Do not attempt to operate or complete any procedure on a machine unless you have received the appropriate training or read the instruction books.

To avoid the risk of RSI (Repetitive Strain Injury), place the machine on a surface which is ergonomically satisfactory to the user. Take frequent breaks during prolonged usage.

1.6 Sharp objects

We do not recommend the use of sharp objects such as knives or screwdrivers to operate the keys. This may shorten the life span of the keys.

1.7 FCC and EMC declarations of compliance

United States

This equipment has been tested and found to comply with the limits for a Class A digital device, pursuant to Part 15 of the FCC Rules. These limits are designed to provide reasonable protection against harmful interference when the equipment is operated in a commercial environment. This equipment generates, uses, and can radiate radio frequency energy and, if not installed and used in accordance with the instruction manual, may cause harmful interference to radio communications. Operation of this equipment in a residential area is likely to cause harmful interference in which case the user will be required to correct the interference at his own expense.

Canada



This digital apparatus does not exceed the Class A limits for radio noise emissions from digital apparatus set out in the Radio Interference Regulations of the Canadian Department of Communications.

Le présent appareil numérique n'émet pas de bruits radioélectriques dépassant les limites applicables aux appareils numériques de la Classe A prescrites dans le Règlement sur le brouillage radioélectrique édicté par le ministère des Communications du Canada.



European Countries



WARNING: This is a Class A product. In a domestic environment, this product may cause radio interference in which the user may be required to take adequate measures.

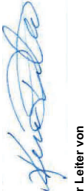

Avery Weigh-Tronix



EN	EU Declaration of Conformity
Model / Type: ZQ375	
Name and address of the manufacturer: Avery Weigh-Tronix® Foundry Lane Smithwick West Midlands B82 3LP ENGLAND	
This declaration of conformity is issued under the sole responsibility of the manufacturer.	
	
ZQ375-SD1 BSF-99-3/6 BSF-1214-15/30/45/60 BSF-1214-15/30 BSF-1214-15/30 BS-1824-35 BS-2424-90/150/200/250	
The object of the declaration described above is in conformity with the relevant Union harmonisation legislation:	
Applicable Directives	Harmonised standards
Electromagnetic Compatibility	EN 61000-4-2:2007
Electrical equipment designed for use in certain voltage limits	EN 60950-1:2006 EN 61132-0 +A1:2010 +A2:2011
Non-Automatic Weighing Instruments	EN 4591:1994 EN 4591:1994 WELMEC 2.1
The notified body, SGS United Kingdom Ltd, 0720 issued the approval for module B. EU type approval for the CE mark is issued under the provisions of Section 2.20 (43) (EU) and based on the certificate:	
UK2924	
The notified body, SGS United Kingdom Ltd, 0720 issued the approval for module D. Conformity to type based on the CE mark is issued under the provisions of Section 2.20 (43) (EU) and based on the certificate:	
GB95/50915	
Additional information:	
Note 1: Trading as Avery Weigh-Tronix, Berkhire, SL4 3BL, England. Note 2: This declaration is only valid if the non-automatic weighing instrument was verified by the manufacturer or with a certificate of conformity issued by a notified body.	
Signed for and on behalf of: Avery Weigh-Tronix 1000 Armstrong Drive, Fairmont, MN, 56031-1439, USA on 2016-04-20	
 K. Deikt Global Head of R&D	

DE	EU-Konformitätserklärung
Modell / Typen: ZQ375	
Name und Anschrift des Herstellers: Avery Weigh-Tronix® Foundry Lane Smithwick West Midlands B82 3LP ENGLAND	
Diese Erklärung ist eine Erklärung der Hersteller für die Einhaltung der Konformitätserklärung.	
	
ZQ375-SD1 BSF-99-3/6 BSF-1214-15/30/45/60 BSF-1214-15/30 BSF-1214-15/30 BS-1824-35 BS-2424-90/150/200/250	
Der oben beschriebene Gegenstand der Erklärung erfüllt die einschlägigen Harmonisierungsrichtlinien der Union:	
Anzuwendende Richtlinien	Harmonisierte Standards
Elektromagnetische Verträglichkeit	EN 61000-4-2:2007
Elektrische Betriebsmittel für die Verwendung innerhalb bestimmter Spannungsgrenzen	EN 60950-1:2006 EN 61132-0 +A1:2010 +A2:2011
Nicht-automatische Waagen	EN 4591:1994 EN 4591:1994 WELMEC 2.1
Die notifizierte Stelle, National Measurement and Regulation Office, 0720 hat die Zulassung für Modul B durch-geführt. Die Zulassung für die CE-Markierung ist auf der Grundlage der in den Bestimmungen des Artikels 11, Absätze 1 bis 3 des Richtlinie 2004/31 (EU) und folgende Bescheinigung ausgestellt:	
UK2924	
Die notifizierte Stelle, SGS United Kingdom Ltd, 0720 hat die Zulassung für Modul D erteilt. Konformität mit der Bauart der Zulassung für die CE-Markierung ist auf der Grundlage der in den Bestimmungen des Artikels 11, Absätze 1 bis 3 des Richtlinie 2004/31 (EU) und folgende Bescheinigung ausgestellt:	
GB95/50915	
Zusatzangaben:	
Anmerkung 1: Trading as Avery Weigh-Tronix, Berkhire, SL4 3BL, England. Anmerkung 2: Diese Erklärung gilt nur, wenn die nicht-automatische Waage vom Hersteller geprüft wurde oder in Vertretung des Herstellers durch eine Bescheinigung einer Notifizierten Stelle.	
Unterschrift für und im Namen von: Avery Weigh-Tronix 1000 Armstrong Drive, Fairmont, MN, 56031-1439, USA am 2016-04-20	
 K. Deikt Globaler Leiter von Forschung und Entwicklung	

FR	Déclaration UE de Conformité
Modèle / Type: ZQ375	
Nom et adresse du fabricant: Avery Weigh-Tronix® Foundry Lane Smithwick West Midlands B82 3LP ENGLAND	
Le présent objet de la déclaration est déclaré sous la seule responsabilité du fabricant.	
	
ZQ375-SD1 BSF-99-3/6 BSF-1214-15/30/45/60 BSF-1214-15/30 BSF-1214-15/30 BS-1824-35 BS-2424-90/150/200/250	
L'objet de la déclaration décrit ci-dessus est conforme à la législation harmonisée de l'Union applicable:	
Les directives en vigueur	Les normes harmonisées ou directives techniques
Compatibilité électromagnétique	EN 61000-4-2:2007
Matériel électrique destiné à être employé dans certaines limites de tension	EN 60950-1:2006 EN 61132-0 +A1:2010 +A2:2011
Instruments de pesage à fonctionnement automatique	EN 4591:1994 EN 4591:1994 WELMEC 2.1
L'organisme notifié, National Measurement and Regulation Office, 0720 a effectué l'homologation pour le module B. L'homologation pour la CE est basée sur les dispositions de l'article 11, alinéa 1, de la Directive 2004/31 (UE) et basé sur le certificat:	
UK2924	
L'organisme notifié, SGS United Kingdom Ltd, 0720 a effectué l'homologation pour le module D. Conformité au type sur la base de la certification de la production est basée sur les dispositions de l'article 11, alinéa 1, de la Directive 2004/31 (UE) et basé sur le certificat:	
GB95/50915	
Informations complémentaires:	
Note 1: L'entreprise agit sous le nom de Avery Weigh-Tronix, Siège social: Admiral House, St Leonards Road, Berkhire, SL4 3BL, Angleterre. Note 2: Cette déclaration est valide seulement si l'instrument de pesage à fonctionnement automatique a été vérifié par le fabricant ou avec une attestation de conformité délivrée par un organisme notifié.	
Signé par et au nom de: Avery Weigh-Tronix 1000 Armstrong Drive, Fairmont, MN, 56031-1439, USA le 2016-04-20	
 K. Deikt Responsable Mondial de la Recherche et du Développement	

NL	EU-Conformiteitsverklaring
Model / Type: ZQ375	
Naam en adres van de fabrikant: Avery Weigh-Tronix® Foundry Lane Smithwick West Midlands B82 3LP ENGLAND	
Dit object van de verklaring wordt verklaard onder volledige verantwoordelijkheid van de fabrikant.	
	
ZQ375-SD1 BSF-99-3/6 BSF-1214-15/30/45/60 BSF-1214-15/30 BSF-1214-15/30 BS-1824-35 BS-2424-90/150/200/250	
Het hierboven beschreven voorwerp is in overeenstemming met de desbetreffende harmonisatieverordening van de Unie:	
Toepasselijke richtlijn	Geharmoniseerde standards of technische specificaties
Elektromagnetische compatibiliteit	EN 61000-4-2:2007
Elektrisch materiaal bestemd voor gebruik binnen bepaalde spanningsgrenzen	EN 60950-1:2006 EN 61132-0 +A1:2010 +A2:2011
Niet-automatische weegwettigen	EN 4591:1994 EN 4591:1994 WELMEC 2.1
De aangewezen instantie, National Measurement and Regulation Office, 0720 heeft de goedkeuring voor de CE-markering verleend op basis van de bepalingen van artikel 11, alinea 1, van Richtlijn 2004/31 (EU) en het certificaat verstrekt:	
UK2924	
De aangewezen instantie, SGS United Kingdom Ltd, 0720 heeft de goedkeuring voor de module D, conformiteit met het type op basis van de goedkeuring van de productie op grond van de bepalingen van artikel 11, alinea 1, van Richtlijn 2004/31 (EU) en het certificaat verstrekt:	
GB95/50915	
Aanvullende informatie:	
Note 1: Het bedrijf handelt als Avery Weigh-Tronix, Zetel: Admiral House, St Leonards Road, Berkhire, SL4 3BL, Engeland. Note 2: Deze verklaring is alleen geldig indien het weegwettig door de fabrikant is goedgekeurd, of anderszins door een gecertificeerd organisme op grond van een certificaat van conformiteit afgegeven door een bevoegd instantie.	
Ondertekend voor en namens: Avery Weigh-Tronix 1000 Armstrong Drive, Fairmont, MN, 56031-1439, USA op 2016-04-20	
 K. Deikt Wereldwijd Hoofd van Onderzoek en Ontwikkeling	

IT	Dichiarazione di Conformità UE
Modello / Tipo: ZQ375	
Nome e indirizzo del fabbricante: Avery Weigh-Tronix® Foundry Lane Smithwick West Midlands B82 3LP ENGLAND	
L'oggetto della dichiarazione di conformità è dichiarato sotto la responsabilità del fabbricante.	
	
ZQ375-SD1 BSF-99-3/6 BSF-1214-15/30/45/60 BSF-1214-15/30 BSF-1214-15/30 BS-1824-35 BS-2424-90/150/200/250	
L'oggetto della dichiarazione di cui sopra è conforme alla seguente normativa di armonizzazione dell'Unione:	
Directive applicabili	Armonizzate norme tecniche
Compatibilità elettromagnetica	EN 61000-4-2:2007
Materiali elettrici destinati ad essere adoperati entro alcuni limiti di tensione	EN 60950-1:2006 EN 61132-0 +A1:2010 +A2:2011
Strumenti per pesare a funzionamento automatico	EN 4591:1994 EN 4591:1994 WELMEC 2.1
L'ente notificato, National Measurement and Regulation Office, 0720 ha dato l'approvazione del modulo B. L'approvazione per la CE è basata sulle disposizioni dell'articolo 11, paragrafo 1, della direttiva 2004/31 (UE) e ha rilasciato il certificato:	
UK2924	
L'ente notificato, SGS United Kingdom Ltd, 0720 ha dato l'approvazione per il modulo D. Conformità al tipo con la garanzia di qualità del processo di produzione è basata sulle disposizioni dell'articolo 11, paragrafo 1, della direttiva 2004/31 (UE) e ha rilasciato il certificato:	
GB95/50915	
Informazioni supplementari:	
Note 1: L'ITV Ltd trading as Avery Weigh-Tronix, Berkhire, SL4 3BL, Engeland. Note 2: Questa dichiarazione è valida solamente se lo strumento di pesatura non automatico è stato verificato dal fabbricante o provato da un certificato di conformità rilasciato da un organismo notificato.	
Firmato in nome e per conto di: Avery Weigh-Tronix 1000 Armstrong Drive, Fairmont, MN, 56031-1439, U.S.A. su 2016-04-20	
 K. Deikt Responsabile Globale della Ricerca e Sviluppo	

ES	Declaración UE de Conformidad
Modelo / Tipo: ZQ375	
Nombre y dirección del fabricante: Avery Weigh-Tronix® Foundry Lane Smithwick West Midlands B82 3LP ENGLAND	
El objeto de la declaración de conformidad es objeto de la exclusiva responsabilidad del fabricante.	
	
ZQ375-SD1 BSF-99-3/6 BSF-1214-15/30/45/60 BSF-1214-15/30 BSF-1214-15/30 BS-1824-35 BS-2424-90/150/200/250	
El objeto de la declaración descrita anteriormente es conforme con la legislación de armonización pertinente de la Unión:	
Directivas aplicables	Normas armonizadas u especificaciones técnicas
Compatibilidad electromagnética	EN 61000-4-2:2007
Material eléctrico diseñado para ser usado con determinados límites de tensión	EN 60950-1:2006 EN 61132-0 +A1:2010 +A2:2011
Instrumentos de pesaje funcionamiento automático	EN 4591:1994 EN 4591:1994 WELMEC 2.1
El organismo notificado, National Measurement and Regulation Office, 0720 ha realizado la aprobación para el marcado CE basándose en las disposiciones del artículo 11, apartado 1, de la Directiva 2004/31 (UE) y expedite el certificado:	
UK2924	
El organismo notificado, SGS United Kingdom Ltd, 0720 ha realizado la aprobación para el marcado D. Conformidad al tipo en la garantía de calidad del proceso de producción es basado en las disposiciones del artículo 11, apartado 1, de la Directiva 2004/31 (UE) y expedite el certificado:	
GB95/50915	
Información adicional:	
Note 1: ITV Ltd trading as Avery Weigh-Tronix, Berkhire, SL4 3BL, Anglaterra. Note 2: Esta declaración es válida solamente si el equipo de pesaje no automático ha sido verificado por el fabricante o con un certificado de conformidad emitido por un organismo notificado.	
Firmado en nombre de: Avery Weigh-Tronix 1000 Armstrong Drive, Fairmont, MN, 56031-1439, EE.UU. el 2016-04-20	
 K. Deikt Jefe Global de Investigación y Desarrollo	



2 Introduction

This manual covers operation of the ZQ375 Checkweigher from Avery Weigh-Tronix. The checkweigher consists of a bench scale, an attached column and the ZQ375 Checkweigher head or indicator.

The ZQ375 Checkweigher is a reliable, easy to operate, high speed weighing scale, designed to allow entry of a target weight, along with selected over and under weight limits for the rapid processing of items that must be checked for conformity to a precise weight range. It offers a range of standard statistical packages to allow precise monitoring of any pack run. The data received enables the operation to be fine-tuned to maximise performance and profitability.

It may be used in stand-alone or interfaced applications. The ZQ375 incorporates serial multi-scale communications capabilities. The scale is housed in a watertight enclosure to permit use in wet environments and can be washed down as necessary to meet sanitary requirements.

This scale has been calibrated and inspected for mechanical and electronic integrity prior to shipment. It should be free of defects and in perfect operating condition upon receipt. To confirm this, the scale should be inspected immediately for any physical damage incurred in transit. If the scale is damaged, contact your local Avery Weigh-Tronix supplier.

2.1 Initial setup

Unpack the unit and place it on a stable, non-vibrating, level surface. Feet can be adjusted to level the scale by loosening the locking sleeve and rotating the foot in or out until the base becomes level. Use the bubble level located between the scale and the column.

Once level, tighten the locking sleeve up against the base to completely cover the feet's threads and to keep the feet from turning. See [Figure 2.1](#).

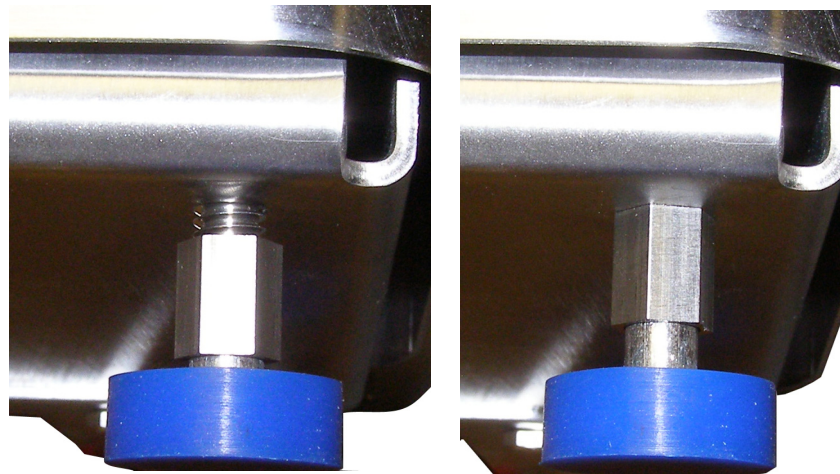

Figure 2.1 Locking sleeve shown in unlocked and locked position

Plug the unit into an easily accessible, grounded power receptacle. See [General information and warnings on page 7](#) for a complete list of precautions concerning the electrical safety of this product and for cleaning procedures.

2.2 Front panel

The front panel, shown in [Figure 2.2](#), consists of the keys and the display.

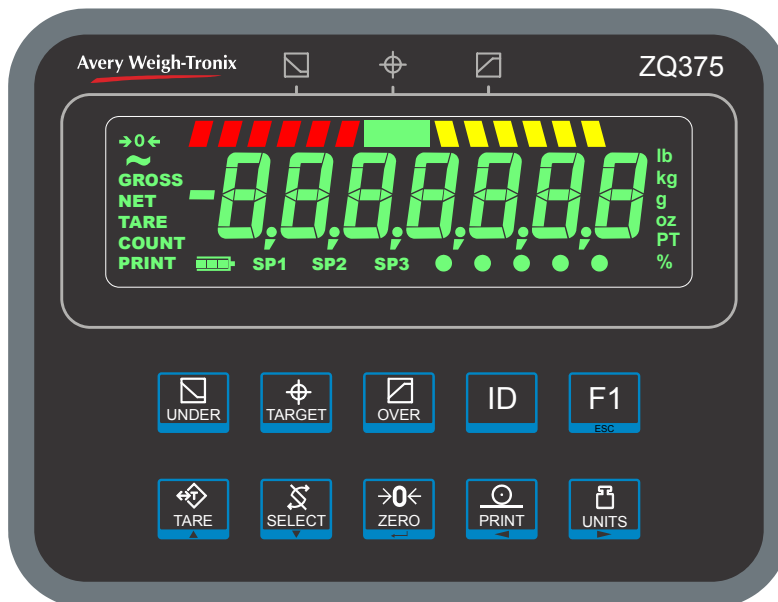







Figure 2.2 ZQ375 front panel



Never press a key with anything but your finger. Damage to the overlay may result if sharp or rough objects are used.

The function of the keys on the front panel are listed below.

	<p>Weigh / Checkweigh mode - In weigh mode the TARE key will work as configured via the Admin menu.(See the Service manual). In checkweigh mode, the TARE key does not function and the display will show cAnt. Menu navigation - Acts as an up arrow key. Numeric / Tolerance Entry - Increments a value.</p>
	<p>Weigh / Checkweigh mode - Press this key to change from weighing mode to checkweighing mode and vice versa. Menu navigation - Acts as a Down Arrow key. Numeric / Tolerance Entry - Decrements a value.</p>
	<p>Weigh / Checkweigh mode - Press to perform a print function. Menu navigation - Functions as the Left Arrow key. Numeric / Tolerance Entry - Functions as a backspace.</p>
	<p>Weigh / Checkweigh mode - Press to zero the weight display. Menu navigation - Functions as an Enter key to accept displayed choices. Numeric / Tolerance Entry - Functions as an Enter key.</p>
	<p>Weigh / Checkweigh mode - Press UNITS to cycle the displayed unit of measure through all the available units of measure. Menu navigation - Functions as the Right Arrow key. Numeric / Tolerance Entry - Moves the cursor position to the right in the Numeric Entry Procedure.</p>

	<p>Weigh / Checkweigh mode - Press UNDER to briefly display the active under value. Press and hold UNDER to add or modify an existing under value tolerance.</p> <p>Menu navigation - N/A</p> <p>Numeric / Tolerance Entry - N/A</p>
	<p>Weigh / Checkweigh mode - TARGET key acquires a target value, when applicable. Its function changes in different applications. See the appropriate application section.</p> <p>Menu navigation - N/A</p> <p>Numeric / Tolerance Entry - N/A</p>
	<p>Weigh / Checkweigh mode - Press OVER to briefly display the active over value. Press and hold OVER to add or modify an existing over value tolerance.</p> <p>Menu navigation - N/A</p> <p>Numeric / Tolerance Entry - N/A</p>
	<p>Weigh / Checkweigh mode - Press the ID key briefly to view the active ID number. Press and hold the ID key to view a prompt for ID number entry. Use the Numeric Entry Procedure on page 19 to scroll in a new ID.</p> <p>Menu navigation - N/A</p> <p>Numeric / Tolerance Entry - N/A</p>
	<p>Weigh / Checkweigh mode - Press to access PLU database, if enabled. Press and hold to access the menu password display.</p> <p>Menu navigation - Press to escape a screen without doing anything and move up in the menu.</p> <p>Numeric / Tolerance Entry - Press to escape a screen without doing anything and move up in the menu.</p>



EU trade regulations state a scale is not allowed to display more than 20 divisions below gross zero. Any weight below this allowable limit will cause the display to show under bars (_ _ _).

*When a tare is active, EU trade regulations do not allow the scale to be zeroed. If the scale displays under bars with no weight on the scale and the **ZERO** key will not re-zero the scale, this could mean the zero was changed prior to setting a tare.*

*To clear this, press and hold the **TARE** key until **CLEAR** is displayed and then press the **ZERO** key. The scale should now display gross zero.*

2.2.1 Annunciators

The annunciators on the display are shown and labeled in [Figure 2.3](#).

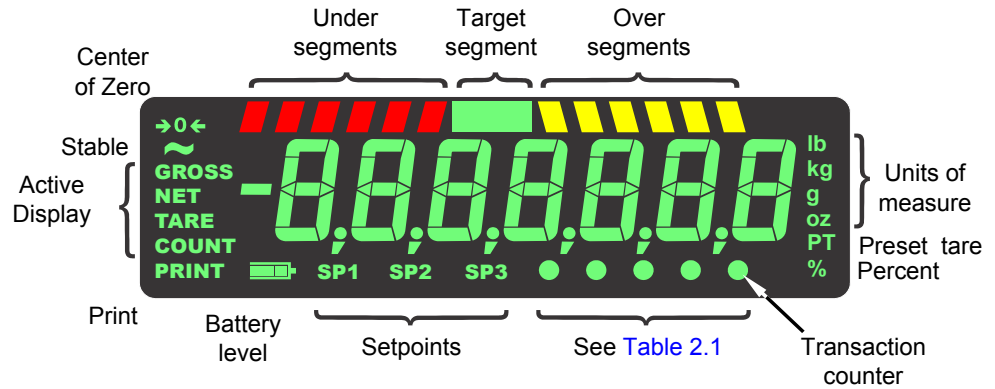

Figure 2.3 Annunciators

These annunciators will light during operation to inform the user of the weighing mode, active unit of measure, etc.

Table 2.1 Circle Annunciator assignments

Annunciator	Indicates
Circle 1 (left most)	Network activity
Circle 2	Custom unit
Circle 5	Transaction counter
Gross + Circle 5	Gross total
Net + Circle 5	Net total
Tare + Circle 5	Transaction total

2.3 Tolerance entry procedure



If you are in a target or tolerance value entry screen and no key is pressed within five seconds, the scale will act as if the **F1/Escape** key was pressed and return to the previous screen without saving any information.

When you are in a tolerance entry screen the yellow **OVER** segments flash as a reminder. [Figure 2.4](#) shows the key functions when in this mode.

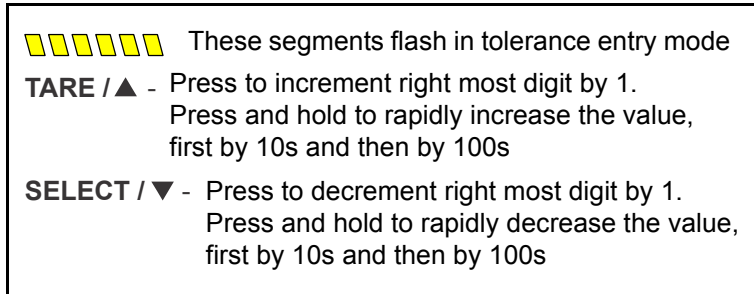

Figure 2.4 Key functions in tolerance entry

In tolerance entry screens, the segments shown in [Figure 2.4](#) flash. Use the keys, as described in [Figure 2.4](#), to enter a value on the display. Following is an example:

Example: To increase a value of 0.002 to 0.125:

Press and hold **TARE(▲)** key until the number approaches **0.125**. Number will increase by **0.010s** for a short time and then by **0.100s**.

Press and release **TARE(▲)** to increment the right most digit by 1.

If you overshoot, press and release **SELECT(▼)** to decrement the right most digit by 1.

Press and hold **SELECT(▼)** to decrease the value by **0.010s** and then by **0.100s**, the longer you hold it.

When the display show 0.125, or the value you desire, press the **ZERO** key to enter or accept the value. The screen returns to the previous mode.

2.4 Numeric entry procedure

The keys in [Figure 2.5](#) have alternate functions in numeric entry screens.

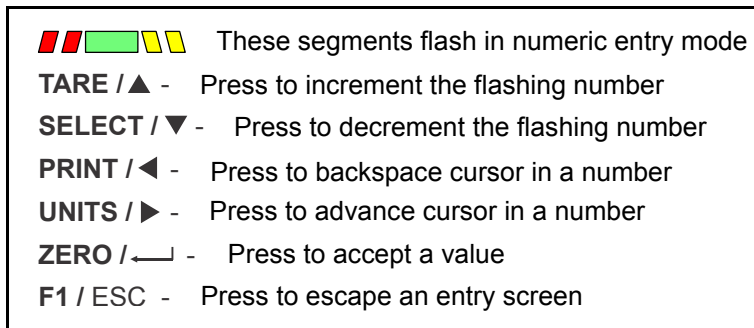

Figure 2.5 Key function during numeric entry

Use the keys, as described in [Figure 2.5](#), to enter a value on the display. Following is an example:

Example: To key in the number 507:

Repeatedly press the **TARE(▲)** or **SELECT(▼)** key until **5** appears on the display.

Press the **UNITS(→)** key once to move cursor one space to the right.

Repeatedly press the **TARE(▲)** or **SELECT(▼)** key until **0** appears on the display.

Press the **UNITS(→)** key once to move cursor one space to the right.

Repeatedly press the **TARE(▲)** or **SELECT(▼)** key until **7** appears on the display.

Press the **ZERO** key to enter or accept the value.

Press the **PRINT(◀)** key to move the entry function one digit to the left. This effectively deletes the current value in that position and allows you to enter a new value in that position.

2.5 ID Entry Procedure

1. To enter an ID number, press and hold the **ID** key ...

The current ID number is displayed with the digit or digits flashing.

2. Within five seconds begin to use the [Numeric entry procedure on page 20](#) to scroll in a new ID and press **ZERO** to accept.
3. The new ID number is now active.



If the entry screen times out and disappears, repeat step 1 and try again. You must start the number entry procedure within five seconds.

2.6 String index/character data entry

Below are guidelines to create or edit text and scale information for print formats. This is a sample of a string entry display.

When these segments are flashing, you are in the string index select mode. In this mode you select the index character you want to edit or add/delete a character.



String Index
number

Character
(ASCII characters
are entered as
decimal values)

Left-flashing bar graph segments indicate you are in the String Index select mode. Use the Table 1 key legend to:

- move to the index number you want to edit
- add a new index number
- delete an existing index number.

Table 1: Key Action When In The String Index Select Mode						
Action	TARE	SELECT	ZERO	PRINT	UNITS	F1
Momentary Key Press	Does nothing	Selects the index character for editing using the key actions in Table 2	EXIT	Moves left one position in the index	Moves right one position in the index	Escape Edit mode and Abort all changes
Long Key Press	Deletes current character	Inserts new character before this point. Default character added is 32 (space)	EXIT	Page Up (Decrements index by 10)	Page Down (Increments index by 10)	Escape Edit mode and Abort all changes

After you select the index number, use the Table 2 key actions to edit the character for that index number.

Table 2: Key Action When In The Character Edit Mode						
Action	TARE	SELECT	ZERO	PRINT	UNITS	F1
Single Key Press	Increments the flashing digit by 1	Decrements the flashing digit by 1	Enter	Delete flashing digit	Add Digit	ESC/Abort
Long Key Press	Move flashing digit left	Move flashing digit right	Enter	Delete the entire entry	Does nothing	ESC/Abort

See the ASCII chart on the following page.

Code #	Cont. Char.	Print Char.	Hex	Code #	Cont. Char.	Print Char.	Hex	Code #	Cont. Char.	Print Char.	Hex	Code #	Cont. Char.	Print Char.	Code #	Cont. Char.	Print Char.			
0	NUL		00	045	-	-	2D	090	Z	Z	5A	0128	NA	Ç	0173	NA	;	0218	NA	Γ
01	SOH	☺	01	046	.	.	2E	091	[[5B	0129	NA	ù	0174	NA	«	0219	NA	■
02	STX	☹	02	047	/	/	2F	092	\	\	5C	0130	NA	é	0175	NA	»	0220	NA	■
03	ETX	♥	03	048	0	0	30	093]]	5D	0131	NA	â	0176	NA	⋮	0221	NA	■
04	EOT	♦	04	049	1	1	31	094	^	^	5E	0132	NA	ä	0177	NA	⋮	0222	NA	■
05	ENG	♣	05	050	2	2	32	095	_	_	5F	0133	NA	à	0178	NA	▬	0223	NA	■
06	ACK	♠	06	051	3	3	33	096	`	`	60	0134	NA	á	0179	NA		0224	NA	α
07	BEL		07	052	4	4	34	097	a	a	61	0135	NA	ç	0180	NA	†	0225	NA	β
08	BS		08	053	5	5	35	098	b	b	62	0136	NA	ê	0181	NA	‡	0226	NA	Γ
09	HT		09	054	6	6	36	099	c	c	63	0137	NA	ë	0182	NA	‡	0227	NA	Π
010	LF	LF	0A	055	7	7	37	0100	d	d	64	0138	NA	è	0183	NA	¶	0228	NA	Σ
011	VT	♂	0B	056	8	8	38	0101	e	e	65	0139	NA	ÿ	0184	NA	¶	0229	NA	σ
012	FF	FF	0C	057	9	9	39	0102	f	f	66	0140	NA	î	0185	NA	¶	0230	NA	μ
013	CR	CR	0D	058	:	:	3A	0103	g	g	67	0141	NA	ï	0186	NA	¶	0231	NA	τ
014	S0	🎵	0E	059	;	;	3B	0104	h	h	68	0142	NA	ÿ	0187	NA	¶	0232	NA	φ
015	S1	⚙	0F	060	<	<	3C	0105	i	i	69	0143	NA	ÿ	0188	NA	¶	0233	NA	θ
016	DLE	4	10	061	=	=	3D	0106	j	j	6A	0144	NA	É	0189	NA	¶	0234	NA	Ω
017	DC1	3	11	062	>	>	3E	0107	k	k	6B	0145	NA	æ	0190	NA	¶	0235	NA	δ
018	DC2	ø	12	063	?	?	3F	0108	l	l	6C	0146	NA	æ	0191	NA	¶	0236	NA	∞
019	DC3	∅	13	064	@	@	40	0109	m	m	6D	0147	NA	ô	0192	NA	¶	0237	NA	∅
020	DC4	β	14	065	A	A	41	0110	n	n	6E	0148	NA	ö	0193	NA	¶	0238	NA	ε
021	NAK	§	15	066	B	B	42	0111	o	o	6F	0149	NA	ò	0194	NA	¶	0239	NA	∩
022	SYN		16	067	C	C	43	0112	p	p	70	0150	NA	û	0195	NA	¶	0240	NA	≡
023	ETB	—	17	068	D	D	44	0113	q	q	71	0151	NA	ù	0196	NA	—	0241	NA	±
024	CAN	↑	18	069	E	E	45	0114	r	r	72	0152	NA	ÿ	0197	NA	+	0242	NA	≥
025	EM	↓	19	070	F	F	46	0115	s	s	73	0153	NA	Ö	0198	NA	†	0243	NA	≤
026	SUB	→	1A	071	G	G	47	0116	t	t	74	0154	NA	Ü	0199	NA	¶	0244	NA	[
027	ESC	←	1B	072	H	H	48	0117	u	u	75	0155	NA	é	0200	NA	¶	0245	NA]
028	FS	—	1C	073	I	I	49	0118	v	v	76	0156	NA	É	0201	NA	¶	0246	NA	÷
029	GS	—	1D	074	J	J	4A	0119	w	w	77	0157	NA	ÿ	0202	NA	¶	0247	NA	≈
030	RS	5	1E	075	K	K	4B	0120	x	x	78	0158	NA	Æ	0203	NA	¶	0248	NA	°
031	US	6	1F	076	L	L	4C	0121	y	y	79	0159	NA	f	0204	NA	¶	0249	NA	•
032	SP		20	077	M	M	4D	0122	z	z	7A	0160	NA	±	0205	NA	=	0250	NA	.
033	!	!	21	078	N	N	4E	0123	{	{	7B	0161	NA	í	0206	NA	¶	0251	NA	√
034	"	"	22	079	O	O	4F	0124			7C	0162	NA	ó	0207	NA	±	0252	NA	∅
035	#	#	23	080	P	P	50	0125	}	}	7D	0163	NA	ú	0208	NA	±	0253	NA	²
036	\$	\$	24	081	Q	Q	51	0126	~	~	7E	0164	NA	ñ	0209	NA	¶	0254	NA	■
037	%	%	25	082	R	R	52	0127	DEL	□	7F	0165	NA	Ñ	0210	NA	¶	0255	NA	
038	&	&	26	083	S	S	53					0166	NA	ª	0211	NA	¶			
039	'	'	27	084	T	T	54					0167	NA	º	0212	NA	¶			
040	((28	085	U	U	55					0168	NA	¿	0213	NA	¶			
041))	29	086	V	V	56					0169	NA	ƒ	0214	NA	¶			
042	*	*	2A	087	W	W	57					0170	NA	ƒ	0215	NA	¶			
043	+	+	2B	088	X	X	58					0171	NA	½	0216	NA	¶			
044	,	,	2C	089	Y	Y	59					0172	NA	¾	0217	NA	¶			

2.7 Powering up the ZQ375

Power is always on as long as the power cable is plugged into the appropriate electrical outlet. Power can be supplied by:

- AC power cord connected to a properly grounded outlet (100 VAC - 240 VAC, 50 or 60 Hz)
- AC to DC power converter. (12 to 36 VDC)
- Optional ZQ-BAT rechargeable battery

2.8 Battery option

The ZQ375 can be operated on battery power by the ZQ-BAT battery option. See [Figure 2.6](#).



Figure 2.6 ZQ-BAT battery option installed in the column

2.8.1 Installation

The battery pack is easy to install. The projections on the side of the pack slide into the slots in the column. The tab on the top of the pack goes over the threaded stud on the column and the pack is secured in place with the star knob. See [Figure 2.7](#).

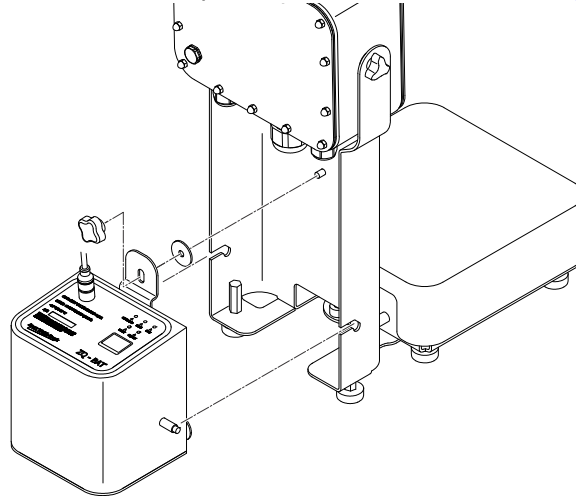

Figure 2.7 ZQ-BAT installation

Attach the battery cable from the indicator to the connector on the top of the battery.

The battery has five annunciator lights to tell you when the unit is charging, when the battery level is low or high, when there is a fault in the battery and when the battery is on or off. Below these lights is the **ON/OFF** button. See [Figure 2.8](#).

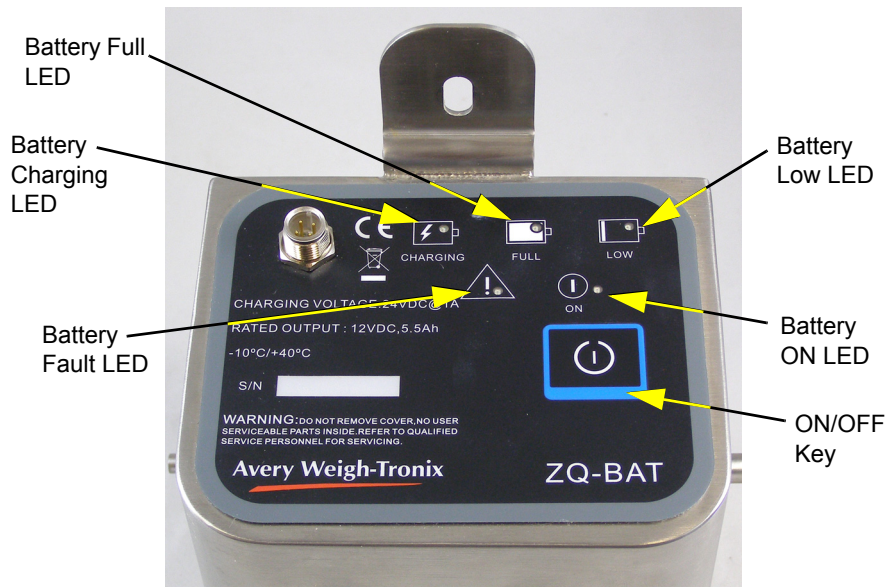

Figure 2.8 Top of ZQ-BAT battery pack

2.8.2 Proper charging of the ZQ-BAT

Charging the battery pack using the supplied wall charger

1. Turn the battery pack ON.
2. Plug the charger into an outlet, then connect it to the battery.

The *LOW* and *FAULT* indicators may turn on if the battery pack is not switched on.
3. Once connected to the charger, the *CHARGING* indicator will blink green to indicate the battery is in a slow charge state.
4. After 75 seconds the charger will automatically switch to its fast charge state, and the indicator will stay solid green.
5. Once the battery is fully charged, the *CHARGING* indicator will shut off and the *FULL* indicator will turn green.
6. Disconnect the battery from the charger and turn the battery pack OFF.



Frequent charging of a battery that is not in a low state will decrease the battery life span.

Charging the battery pack through a ZQ375 indicator:

1. Connect the battery pack to a ZQ375 indicator and turn the battery pack ON.
2. Plug the indicator power cord into an outlet

The *LOW* and *FAULT* indicators may turn on if the battery pack is not switched on.
3. The *CHARGING* indicator will blink green to indicate the battery is in a slow pre-charge state.
4. After 75 seconds the charger will automatically switch to its fast charge state, and the indicator will stay solid green.
5. Once the battery is fully charged, the *CHARGING* indicator will shut off and the *FULL* indicator will turn green. At this point the indicator will stop the charging sequence and simply maintain the voltage of the battery until it is needed. This prevents the battery from being overcharged, allowing it to be left either ON or OFF without damage.
6. The battery can now be used to power your ZQ indicator and scale system.

Battery life is rated at 16 hours continuous duty.

If so configured, the checkweigher will automatically switch off the battery after a set amount of time if no scale motion or keypad activity occurs.



WARNING: Ensure the battery is fully charged before its first use.

Begin recharging the battery pack as soon as possible after the LOW indicator LED comes on. Discharging the battery too far beyond this point may damage the battery.

2.8.3 Battery states indicated by LEDs

Table 2.2 Battery Power States

Battery Power State	LED Status	Notes
	Power	
	 ON	
Powered ON	ON	The battery must be powered on to power an indicator and to be recharged
Powered OFF	OFF	The battery can be powered off to conserve charge when not in use

Table 2.3 Battery Voltage States





Battery Voltage States	LED Status		Notes
	LOW	Fault	
	 LOW		
Above 9.3V	OFF	OFF	The battery can be used to power an indicator
Below 9.3V	ON	OFF	The battery should be recharged as soon as possible
Fault	ON	FLASHING	A charger has been connected without the battery being powered on

Table 2.4 Battery Charging States

Battery Charging States	LED Status			Notes
	Charging	Full	Fault	
	 CHARGING	 FULL		
Pre-Charge	FLASHING	OFF	OFF	The battery is slowly charged for 75 seconds
Fast Charge	ON	OFF	OFF	No faults were found so the battery is now charged quickly
Fully Charged (Wall Charger)	OFF	ON	OFF	The unit is fully charged and should be disconnected from the power supply
Maintenance Charging (QZ375)	OFF	ON	OFF	The unit is fully charged and the indicator is simply maintaining the correct voltage
Waiting	OFF	OFF	FLASHING	Over Temp - Battery is hot and needs to cool before charging continues
				No Power - The battery circuit has not been turned on
Charging Failure	OFF	OFF	ON	Battery is above the allowed voltage
				Battery has been discharged below 5V
				Other failure

2.8.4 Checkweigher Operation on Battery Power

- To operate the checkweigher using the battery pack, be sure the pack is fully charged and connected to the checkweigher. Press the **ON/OFF** key on the battery pack ...

The Battery **ON** LED will light.

- The ZQ375 should power up as soon as the battery is turned on.
- To power down the battery and the ZQ375, press the **ON/OFF** key ...

The Battery **ON** LED light will go out and the ZQ375 will power down.

2.9 Light stack option

The ZQ375 has an optional light stack for a bright, visual sign that an object on the scale is over, under or at the acceptable target weight. The unit, shown installed in [Figure 2.9](#), attaches to the column in exactly the same way as the battery pack and connection is also made with a simple screw-in connector.



Figure 2.9 Light stack option

2.9.1 Light stack operation

The lights function the same way as the bargraph, showing red for under, orange for over and green for accept conditions.

3 Checkweighing applications

The ZQ375 has five applications for different levels of checkweighing and specialty checkweighing.

- Sim375** Simple, quick checkweighing application. Fast and simple to set up. Displays a \pm deviation reading from the target weight set within the scale. See [Sim375 application on page 34](#).
- Mid375** Mid-level checkweighing. This application uses weigh mode versus deviation mode. It is fast and simple to set up and displays target weight in gross or net weight. Target weight is setup by either the **TARGET** key or entered through the indicator keypad. See [Mid375 application on page 36](#).
- Adv375** Advanced checkweighing. This is like Mid375 but adds a Product Look Up (PLU) database. This allows you to quickly activate target weights and high and low tolerances for up to 500 products from the PLU database. Statistical packages like X-bar/R and Standard Deviation are also included in this application. See [Adv375 application on page 41](#).
- Per375** Percent checkweighing allows the operator to accurately increase the weight of a product by a set percentage of the starting weight. See [Per375 application on page 46](#).
- Grad375** This application categorizes weight within up to 10 bands or weight windows. See [Grad375 application on page 49](#).

Applications are enabled in a password protected menu. See the Service manual (PN AWT35-500813 for the English version).

3.1 Checkweighing terminology

There are some terms you should understand when checkweighing.

Target	The exact weight desired
Target-Hi	Target weight plus the Tolerance-Hi
Target-Low	Target weight minus the Tolerance-Low
Tolerance-Low	Weight allowed under the target weight but still considered acceptable
Tolerance-Hi	Weight allowed over the target weight but still considered acceptable
Sample	Adds "Toler-Hi" and subtracts "Toler-Lo" from target weight for over/accept/under ranges. Example: Toler-Hi = 1.0 Toler-Lo = 2.0 Target = 4.0 "Target" – "Toler-Lo" = "Lower Acceptable Target Limit" or (4-2=2) Therefore all weights below 2 are considered under weight. "Target" + "Toler-Hi" = "Upper Acceptable Target Limit" or (4+1=5) Therefore all weights above 5 are considered over weight. This would mean all weights above 2 and below 5 would be acceptable as being within target sample tolerances.

Limits

Any weight above "Targ-Lo" and below "Targ-Hi" is acceptable as being within target limits.

Example: Targ-Hi = 6.0 Targ-Lo = 2.0

All weights below 2 are considered under the target weight.

All weights above 6 are considered over the target weight.

Halfway between the upper and lower target value limits is the value 4, This is the calculated target value.

This would mean all weights above 2 and below 6 would be acceptable as being within the target limits.

3.2 Normal weighing procedures

The Sim375, Mid375 and Adv375 applications allow normal weighing using gross and net weighing. Below are the steps for the normal weighing practices.

3.2.1 Gross weighing



*If enabled, press **UNITS** to change the unit of measure.*

To perform gross weighing, power up the unit and follow these steps:

1. Press the **SELECT** key if the *GROSS* annunciator is not lit ...
The *GROSS* annunciator lights and the scale is in gross weighing mode.
2. Empty the scale and press **ZERO** to zero the display ...
0 is displayed and the *center-of-zero* annunciator lights.
3. Place item to be weighed on the scale ...
Weight is displayed.
4. Repeat steps 1 through 3.

3.2.2 Tare/Net weighing



In the Sim375 application, the tare functionality is not available

There are two kinds of tare entry. These are enabled when the indicator is configured.

- Pushbutton tare
- Preset tare



If Preset Tare is enabled, Pushbutton Tare is automatically disabled.

There is also a function called auto tare clear. If this is enabled, after a weighment, when the weight falls into the gross zero band and is steady, any tare is removed from the indicator. No tare remains active between weighments.

The two types of tare are explained below.

Using Pushbutton Tare (if enabled)

To perform a net weighment using pushbutton tare, power up the unit and follow these steps:

1. Empty the scale and press **ZERO** ...
0 is displayed and the *center-of-zero* annunciator lights.
2. Place item to be tared on the scale ...
Weight is displayed.
3. Press **TARE** ...
0 is displayed and the *NET* annunciator lights.



To clear a tare weight, remove all weight from the scale and press **TARE**.

4. Place material to be weighed on the scale ...
Net weight of material is displayed.
5. Repeatedly press **SELECT** to view the gross, tare, and net values.
6. Remove all weight from the scale.
7. To repeat weighing the net weight, place a container of the same weight on the scale and then the material to be weighed ...
Net weight of material is displayed.
8. To remove the tare, remove all weight from the scale. With **0** displayed, press **TARE**.
The tare is cleared and the scale is in gross weigh mode.

Using Preset Tare (if enabled)

Preset tares are entered in a password protected menu. Check with your supervisor on this Mid375 and Adv375 feature. There can be up to 10 tare registers numbered 1-10. To perform a net weighment using one of the preset tares, power up the unit, go to normal gross weighing mode and follow these steps:

1. Empty the scale and press **ZERO** ...
0 is displayed and the *center-of-zero* annunciator lights.
2. Press **TARE** ...
Tare register number entry screen appears.
3. Use the [Numeric entry procedure on page 20](#) and key in the preset tare register number and press **ZERO** ...
-X is displayed and the *NET* annunciator lights. **X** is the recalled tare value.

4. Place the container or object (equal to tare value) to be tared and material to be weighed on the scale ...
Net weight of material is displayed.
5. Repeatedly press **SELECT** to view the gross, tare, and net values.
6. Remove all weight from the scale ...
-X is displayed.
7. Repeat steps 4 - 6 until you are finished using that tare weight.

3.3 Sim375 application

This section applies if the Sim375 application is enabled. See the Service manual for information on enabling the applications.

The SIM375 application is a fast and efficient checkweighing application that displays the \pm deviation from a target point set by the operator.



Using Pushbutton or Preset Tare is not available in the SIM375 application

3.3.1 Checkweighing

Switching Between Checkweighing and Normal Weighing Mode

To switch between checkweighing and normal weighing mode, press **SELECT**. When the *GROSS* annunciator is displayed, the unit is in normal weighing mode. Press **SELECT** again and the *GROSS* annunciator disappears. The unit is now in checkweighing mode. The display may show a negative weight and the *Under* segments of the bargraph may be lit if there is an active target value.

Setting a New Target Weight and Simple Checkweighing

1. With the unit in Checkweighing mode, press **ZERO** to zero the scale and place an item of the correct weight on the scale and press **TARGET** ...

The scale will read **0** weight and the center *Accept* segment will light showing the target weight has been set successfully.



*If motion is present for greater than 2-3 seconds after the **TARGET** key press, the target operation will be aborted and the word **cant** will be displayed briefly.*

2. Clear the scale and place the next item on the scale ...

The bargraph will show the item is under the target weight, over the target weight or on target.



By default the Target segment lights if the weight is within \pm the high and low tolerance of the target weight. The over and under segments each represent 1 division.

3. Repeat step 2 for all the other items to be weighed.

View the High and Low Tolerances

1. To view the high tolerance, press and hold **OVER** ...
toL-hi (high tolerance) is briefly displayed, then the value for this high tolerance is briefly displayed before the normal checkweighing mode returns.
2. To view the low tolerance, press and hold **UNDER** ...
toL-Lo (low tolerance) is briefly displayed then the value for this low tolerance is briefly displayed before the normal checkweighing mode returns.

Set New High and Low Tolerances



*You can escape from an entry screen or choice level. Press **F1** and the action is aborted and the display returns to its previous state.*

To set custom tolerances follow these steps:

1. Press **UNDER** to set the low tolerance ...
x.xxx is displayed. This is the current low tolerance. The *Under* segments also flash.
2. Refer to the [Tolerance entry procedure on page 19](#) and key in a new tolerance and press **ZERO** to accept ...
 Display returns to checkweighing mode with the new low tolerance active.
3. Press **OVER** to set the high tolerance ...
x.xxx is displayed. This is the current high tolerance. The *Over* segments also flash.
4. Refer to the [Tolerance entry procedure on page 19](#) and key in a new tolerance and press **ZERO** to accept ...
 Display returns to checkweighing mode with the new high tolerance active.



The tolerances can be set from 1 division to the capacity of the scale.

3.4 Mid375 application

This section applies if the Mid375 application is enabled. See the Service manual for information on enabling the applications.

In the Mid375 application the checkweigher mode is always active and the target weight is always displayed in either gross or net weight. Unlike the Sim375 application that only displays the deviation from target, the Mid375 application displays the weight.

3.4.1 SELECT key operation

In the Mid375 application, press **SELECT** to cycle through the active display values: GROSS, NET, TARE and TRANSACTION COUNT. The appropriate annunciator will light for each display value. (The transaction count annunciator is the green circle under the right digit on the display.)

3.4.2 Checkweighing

To start checkweighing you need to enter a target weight by using live weight or keying in the value. By default the lower tolerance (Tol-Lo) is -1 division and the high tolerance (Tol-Hi) is +1 division. These tolerances can be adjusted. These steps are described in the following sections.

The ZQ375 adds Tol-Hi and subtracts Tol-Lo from the target weight for over/accept/under ranges.

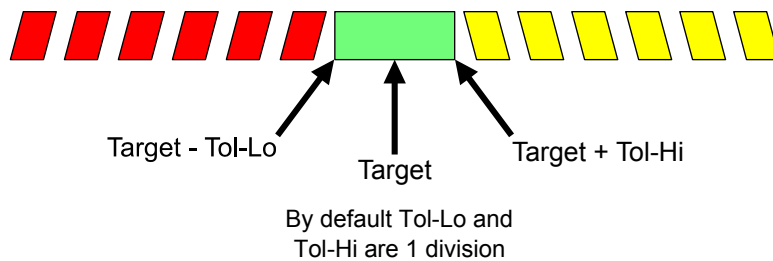

Example: Tol-Hi = 0.1
 Tol-Lo = 0.2
 Target = 4.0

Target – Tol-Lo = Lower Acceptable Target Limit or (4 - 0.2 = 3.8).
 Therefore all weights below 3.8 are considered under weight.

Target + Tol-Hi = Upper Acceptable Target Limit or (4 + 0.1 = 4.1).
 Therefore all weights above 4.1 are considered over weight.

This would mean all weights above 3.8 and below 4.1 would be acceptable as being within target sample tolerances.

3.4.3 Negative checkweighing

Negative checkweighing is functional in the MID375 and ADV375 applications. Follow these steps:

1. Place a full container on the scale and press **TARE**.
2. Remove a desired amount of material from the container and press **TARGET**.
3. Press **TARE** and start the negative checkweigh process by removing material until inside the target zone.

Tolerance values work in opposite fashion:

Target + Lo Tolerance = Target Lo

Target – Hi Tolerance = Target Hi

3.4.4 Sample mode checkweighing

Setting a target weight can be done in two ways:

- Sampling an item of the correct weight
- Entering a known target weight through the front panel



By default in both the quick check and preset target methods, the low tolerance (**toL-Lo**) is -1 division and the high tolerance (**toL-hi**) is + 1 division. These tolerances can be adjusted. See [Set New High and Low Tolerances on page 35](#).



When inside the Gross Zero Band, press **TARGET** and you can adjust the target weight using the [Tolerance entry procedure on page 19](#).

Sampling Method

1. Place an item of the correct weight on the scale and press **TARGET** ...

The scale will show the target weight and the center *Accept* segment will light showing the target weight has been set successfully.



If motion is present for greater than 2-3 seconds after the **TARGET** key press, the target operation will be aborted and the word **cant** will be displayed briefly.

2. Clear the scale and place the next item on the scale ...

The bargraph will show the item is under the target weight, over the target weight or on target.

3. Repeat step 2 for all the other items to be weighed.

Manual Target Weight Entry

1. Empty the scale and press **ZERO** to zero the scale, then press **TARGET** ...

The current value for target is displayed.

2. Use the [Tolerance entry procedure on page 19](#) to key in a value for target and press **ZERO** to accept ...

The target weight becomes active.

3. Place an item on the scale ...

The weight will be displayed and *OVER*, *UNDER* or *ACCEPT* segments will light depending on the weight.

4. Clear the scale.
5. Repeat steps 3 and 4.

View the Target Weight and Upper and Lower Tolerances

1. To view the target weight, press and hold **TARGET** ...
tArGEt is briefly displayed, then the value is briefly displayed before the normal checkweighing mode returns.
2. To view the upper tolerance, press and hold **OVER** ...
toL-hi or **tArGhi** (high tolerance) is briefly displayed, then the value is briefly displayed before the normal checkweighing mode returns.
3. To view the lower tolerance, press and hold **UNDER** ...
toL-Lo or **tArGLo** (low tolerance) is briefly displayed, then the value is briefly displayed before the normal checkweighing mode returns.

Set New Upper and Lower Tolerances

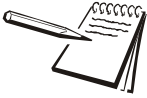

*You can escape from an entry screen or choice level. Press **F1** and the action is aborted and the display returns to its previous state.*

To set custom tolerances follow these steps:

1. Press **UNDER** to set the lower or under tolerance ...
x.xxx is displayed. This is the under tolerance value. The *Under* segments also flash.
2. Refer to the [Tolerance entry procedure on page 19](#) and key in a new tolerance. Press **ZERO** to accept ...
 Display returns to checkweighing mode with the new lower tolerance active.
3. Press **OVER** to set the upper tolerance ...
x.xxx is displayed. This is the over tolerance value. The *Over* segments also flash.
4. Refer to the [Tolerance entry procedure on page 19](#) and key in a new tolerance. Press **ZERO** to accept ...
 Display returns to checkweighing mode with the new upper tolerance active.



The tolerances can be set from 1 division to the capacity of the scale.

3.4.5 Transaction counter

You can view the number of transactions since the last clearing by pressing the **SELECT** key until the transaction count display is shown. The counter is incremented every time **PRINT** is pressed. See example in [Figure 3.1](#).



Figure 3.1 Transaction count display

If enabled in a password protected menu, press and hold **PRINT** to clear the transaction count.

3.5 Adv375 application

This section applies if the Adv375 application is enabled. See the Service manual for information on enabling the applications.

3.5.1 SELECT key operation

In the Adv375 application, press **SELECT** to cycle through the active display values: GROSS, NET, TARE and TRANSACTION COUNT. The appropriate annunciator will light for each display value. (The transaction count annunciator is the green circle under the right digit on the display.)

3.5.2 Checkweighing

The Adv375 application is identical in function to the Mid375 application with the addition of Product Look Ups (PLUs) and the option to use two statistical programs: Standard Deviation and X-Bar/R. See [Statistical Package and Packrun on page 44](#). PLUs consist of a PLU# (1-500), the lower tolerance, the target weight and the upper tolerance. These are created and edited in a password protected menu. See your supervisor for more information.



A short key press of the **OVER**, **UNDER**, and **TARGET** keys will do nothing if the active PLU# is from 1 to 500. If the active PLU# = 0, these keys will work like in the Mid375 application. See [Set New Upper and Lower Tolerances on page 39](#).

If you press and hold the **OVER**, **UNDER**, and **TARGET** keys and the active PLU# = 0 to 500, you will see hi tolerance, target and low tolerance, respectively.

Setting a New Target Weight and Checkweighing



You can escape from an entry screen or choice level. Press **F1** and the action is aborted and the display returns to its previous state.



When inside the Gross Zero Band, press **TARGET** and you can adjust the target weight using the [Tolerance entry procedure on page 19](#).

These steps apply only if the active PLU# is 0.

1. In gross weighing mode, press **ZERO** to zero the scale. Place an item of the correct weight on the scale and press **TARGET** ...

The scale will read show the weight of the item, the center *Accept* segment will light showing the target weight has been set successfully and the *Gross* or *Net* annunciator will be lit.



If motion is present for greater than 2-3 seconds after the **TARGET** key press, the target operation will be aborted and the word **cant** will be displayed briefly.

2. Clear the scale and place the next item on the scale ...

The bargraph will show the item is under the target weight, over the target weight or on target.

3. Repeat step 2 for all the other items to be weighed.

Choosing a PLU and Checkweighing



Over, under and target values for the PLU registers are entered in a password protected menu. Contact your supervisor for information.

Use these steps when you want to recall a PLU and checkweigh.

1. Press **ZERO** to zero the scale, then press **F1** ...

A flashing **0** is displayed prompting you for the PLU # you wish to recall.

2. Use the [Numeric entry procedure on page 20](#) to enter the PLU number and press **ZERO** to accept ...

The PLU values are recalled. The target, upper and lower tolerances become active. If that PLU number has no values assigned, the display will show **cAnt**.

3. Place an item on the scale ...

The scale will show the weight and the bargraph segments will light in accordance with the target and tolerances that are active.

4. Clear the scale and place the next item on the scale ...

The bargraph will show the item is under the target weight, over the target weight or on target.

5. Repeat step 2 through 4 for all the other items to be weighed.

View the Upper and Lower Tolerances

1. To view the upper tolerance, press and hold **OVER** ...

toL-hi (high tolerance) is briefly displayed, then the value is briefly displayed before the normal checkweighing mode returns.

2. To view the lower tolerance, press and hold **UNDER** ...

toL-Lo (low tolerance) is briefly displayed, then the value is briefly displayed before the normal checkweighing mode returns.

Set New Upper and Lower Tolerances



*You can escape from an entry screen or choice level. Press **F1** and the action is aborted and the display returns to its previous state.*

If the active PLU# is 0, you can set custom tolerances. Follow these steps:

1. Press **UNDER** to set the lower or under tolerance ...

x.xxx is displayed. This is the under tolerance value. The *Under* segments also flash.

2. Refer to the [Tolerance entry procedure on page 19](#) and key in a new tolerance. Press **ZERO** to accept ...

Display returns to checkweighing mode with the new lower tolerance active.

3. Press **OVER** to set the upper tolerance ...

x.xxx is displayed. This is the over tolerance value. The *Over* segments also flash.

4. Refer to the [Tolerance entry procedure on page 19](#) and key in a new tolerance. Press **ZERO** to accept ...

Display returns to checkweighing mode with the new upper tolerance active.

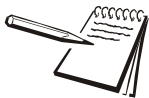

The tolerances can be set from 1 division to the capacity of the scale.

3.5.3 PLU Transaction counter

You can view the number of PLU transactions since the last clearing by pressing the **SELECT** key until the transaction count display is shown. Each PLU has its own counter. The counter is incremented every time **PRINT** is pressed.



Transaction counts and accumulators are stored with each PLU.

3.5.4 Statistical Package and Packrun

If the statistical package, Standard Deviation, is enabled, after a configurable number of transactions have occurred (packrun quantity), the ZQ375 will totalize the number of transactions and compute the standard deviation of the transactions.

Pack Run is the same as the Sample Size or quantity of weighments before a report is automatically printed.

If standard deviation is turned on and Pack Run is set to 0 (zero) you will get individual weights each time the **PRINT** key is pressed and the statistical report when the **PRINT** key is held for 4 seconds. The samples are cleared from memory when printed

If the Pack Run is set for any number of samples, you will get individual weights until you reach the number set for the sample size (pack-run). Once this value has been reached the statistical report will print out, then the samples are cleared from memory.

With Pack Run at 0 place product on scale. When the weight stabilizes press the **PRINT** key. The individual weight will be stored and printed. (Auto Print Feature may be used) Continue weighing product until a statistical report is required.

ACCEPT: 12.34 lb
OVER: 12.36 lb
OVER: 12.64 lb
UNDER: 9.72 lb
ACCEPT: 12.29 lb
UNDER: 0.00 lb

Printing the report:

Press and hold print key for 4 seconds, display will flash "Std-dEv Prn-tot" and the report will be printed, then the samples will be cleared from memory.

Report Example:

Tolerance Hi = 0.35 lb
 Tolerance Lo = 0.25 lb
 Cnt of Over Wt = 2
 Cnt of Under Wt = 1
 Cnt of Target Wt = 3
 Mean Net Wt = 10.30 lb
 Max Net Wt = 12.64 lb
 Min Net Wt = 0.00 lb
 SD Net Wt = 5.05
 CV Net Wt = 0.49 PCT
 Cnt of Tot Wt = 6

If autoprint is enabled or the **PRINT** key is pressed a valid transaction occurs. Valid transactions are counted as one entry in a packrun.

To end a packrun before the configured quantity is met, press and hold **PRINT** and the valid transactions are totaled and standard deviation is performed.

If enabled, the standard deviation report is printed automatically upon completion of the packrun.

3.5.5 X-Bar/R Program

The X-bar/R program is designed to weigh process samples, establish the average weight, calculate the range between high and low weights, and the trend of deviation. If the X-bar/R feature is enabled, the ZQ375 will keep a queue of the average weights of the last eight sample sets. This queue of averages is used to print trend information on the statistical reports.



The Report Printout for the X-Bar/R program can be customized to present statistical data of your choosing. This information is found in the Service manual.

Trend Message	Meaning
1 of 1	The last average in the queue has an error greater than 3x the limit
2 of 3	Two of the last three averages in the queue have an error greater than the limit.
4 of 5	Four of the last five averages have an error greater than the limit.
8 of 8	Eight of eight averages are on the same side of the target weight.

3.6 Per375 application

This section applies if the Per375 application is enabled. See the Service manual for information on enabling the applications.

3.6.1 Checkweighing

The Per375 application is identical in function to the Adv375 application with the exception that weights are now expressed in percentages. PLUs consist of a PLU#, the lower tolerance, the target percentage and the upper tolerance. These are created and edited in a password protected menu. See your supervisor for more information.



A short key press of the **OVER**, **UNDER**, and **TARGET** keys will do nothing if the active PLU# is from 1 to 500. If the active PLU# = 0, these keys will work like in the Mid375 application. See [Set New Upper and Lower Tolerances on page 39](#).

If you press and hold the **OVER**, **UNDER**, and **TARGET** keys and the active PLU# = 1 to 500, you will see hi tolerance, target and low tolerance, respectively. If the active PLU# = 0, then the over, under, target values will be shown, but the values are only temporary ones since the active PLU#=0.

Setting a New Target Percentage and Checkweighing



You can escape from an entry screen or choice level. Press **F1** and the action is aborted and the display returns to its previous state.

These steps apply only if the active PLU# is 0.

1. In gross weighing mode, press **ZERO** to zero the scale. Press **TARGET** ...

The display will show the last target value in percentage and the% annunciator will turn on. The *Target* segment will light.



If motion is present for greater than 2-3 seconds after the **TARGET** key press, the target operation will be aborted and the word **cant** will be displayed briefly.

2. Press **ZERO** to accept the displayed value or use the [Tolerance entry procedure on page 19](#) to key in a new target value and press **ZERO** to accept.

3. Place the item on the scale and press **TARGET** ...

Percent of item on the scale is now displayed. This should be **0.0%**.

4. Add additional weight (for example, by injection) until the target percentage has been reached ...

When the target percentage is reached, the center *Accept* segment will light.

5. Clear the scale and place the next item on the scale. Repeat steps 1 and 4.

Choosing a PLU and Checkweighing

Use these steps when you want to recall a PLU and checkweigh.



Over, under and target values for the PLU registers are entered in a password protected menu. Contact your supervisor for information.

1. Press **ZERO** to zero the scale, then press **F1** ...

A flashing **0** is displayed prompting you for the PLU # you wish to recall.

2. Use the [Numeric entry procedure on page 20](#) to enter the PLU number and press **ZERO** to accept ...

The PLU values are recalled. The target, upper and lower tolerances become active. If that PLU number has no values assigned, the display will show **cAnt**.

3. Place an item on the scale and press **TARGET** ...

The display will show **0.0** and the *Under* segments will light in.

4. Add additional weight until the target percentage has been reached ...

The center *Accept* segment will light.

5. Clear the scale and repeat steps as needed.

View the Upper and Lower Tolerances

1. To view the upper tolerance, press and hold **OVER** ...

toL-hi (high tolerance in percent) is briefly displayed, then the value is briefly displayed before the normal checkweighing mode returns.

2. To view the lower tolerance, press and hold **UNDER** ...

toL-Lo (low tolerance in percent) is briefly displayed, then the value is briefly displayed before the normal checkweighing mode returns.

Set New Upper and Lower Tolerances



*You can escape from an entry screen or choice level. Press **F1** and the action is aborted and the display returns to its previous state.*

If the active PLU# is 0, you can set custom tolerances. Follow these steps:

1. Press **UNDER** to set the lower or under tolerance ...

x.x percent is displayed. This is the under tolerance value. The % annunciator is lit and the *Under* segments also flash.

2. Refer to the [Tolerance entry procedure on page 19](#) and key in a new tolerance. Press **ZERO** to accept ...
Display returns to checkweighing mode with the new lower tolerance active.
3. Press **OVER** to set the upper tolerance ...
x.x percent is displayed. This is the over tolerance value. The% annunciator is lit and the *Over* segments also flash.
4. Refer to the [Tolerance entry procedure on page 19](#) and key in a new tolerance. Press **ZERO** to accept ...
Display returns to checkweighing mode with the new upper tolerance active.

3.7 Grad375 application

This section applies if the Grad375 application is enabled. See the Service manual for information on enabling the applications.

3.7.1 Positive vs. negative grading

Your unit can be configured for positive or negative grading. Positive grading classifies a weight as 1 of 10 weight grades. The process is described in [Positive grading on page 50](#).

Negative grading is used to classify objects removed, one at a time, from a full tote or box. The process is described in [Negative grading with autotare enabled on page 50](#).

3.7.2 Grade classifying

Grade classifying is the same whether your unit is configured for positive or negative grading. You set the weight values for each division between the grades. If the weight on the scale falls below or is equal to the weight value of a grade division, it is in the grade below the line. If it is greater than a weight value, it is in the grade above the line. Default value for Weight Points 2 through 10 is 0. See [Figure 3.2](#) for an illustration.

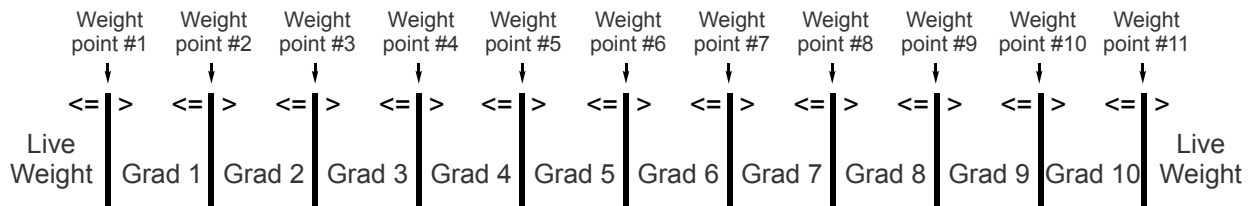

Figure 3.2 Weight grade illustration

3.7.3 Setting weight grades

Follow these steps to set the weight points illustrated in [Figure 3.2](#).

1. With the Grad375 application active, press and hold **TARGET** ...
grAding is displayed.
2. Press **SELECT** ...
grAd 1 is displayed. This is the first weight point that defines the lower limit of Grad 1.
3. Press **SELECT** ...
A numeric entry screen is displayed.
4. Key the first weight point and press **ZERO** to accept ...
grAd 1 is displayed.
5. Press **UNITS** to move to the next weight point ...
grAd 2 is displayed.

- Repeat steps 3 through 5 until you've completed all 11 weight points ...
grAd 11 is displayed.

- Press **TARE** twice ...

Indicator returns to the normal operating mode and the current weight is displayed.

3.7.4 Positive grading

- With the weight points set, zero the scale and place the item to be weighed on the scale.

Any weight below weight point #1 or above weight point #11 will be displayed as weight.

Any other weight will be shown as one of the 10 Grades. The display will show **grAd X**, with **X** being the grade number for that weight.

- Remove the item from the scale and weigh the next item.



You can reduce the number of grades by setting Grad Points to 0.

***For example:** To create 3 grades, set Grad Points 1, 2 and 3 normally. Set Grad Points 4 through 10 to 0 and set Grad Point 11 to the last value to create your third grade.*

3.7.5 Negative grading with autotare enabled

If your unit is configured for negative grading with autotare enabled, follow these steps.

- Zero the empty scale, if necessary.
- Place a tote or box loaded with the items to be graded on the scale ...

The weight is shown briefly and then the scale autotares.

- Remove an item ...

The grade of the removed item is shown for 0.5 seconds and the scale autotares. If the removed item weight is less than the grade 1 value the scale will still perform the autotare when stable.

- Repeat step 3 until all items have been graded.
- Remove the tote and repeat steps 1 through 4.



*If Negative grading autoprint is enabled a print will occur when an item is removed from the scale. See the [Grading \(Format #30\) on page 65](#). If you get out of sequence, start over. With the tote on the scale press the **TARE** key, then remove an item.*

3.7.6 Negative grading with autotare disabled

If your unit is configured for negative grading with autotare disabled, follow these steps:

1. Zero the empty scale, if necessary.
2. Place a tote or box loaded with the items to be graded on the scale and press the **TARE** key.
3. Remove an item ...
The grade of the removed item is shown.
4. Press the **TARE** key.
5. Repeat step 3 until all items have been graded.
6. Remove the tote and repeat steps 1 through 4.

4 Menus

Password protected menus are available to customize the indicator and to view information.

4.1 Accessing the menus

Follow these steps to access the menus in the ZQ375.

1. With the indicator powered up and in normal operating mode, press and hold the **F1** key ...

Pass is displayed, prompting you to enter the password.

2. Key in the password for the menu you want and press the **ZERO** key ...

The first item in the top level of the menu you accessed is displayed.

3. Use the navigation keys, shown below, to navigate through the menu structure. The symbols in the chart appear on the bottom of the keys.

Menu Navigation Keys:

Press **SELECT**/ ▼ to move down in a menu
 Press **TARE**/ ▲ to move up in a menu, except at the bottom item in a menu, then use **ZERO**/ ← or **F1**
 Press **PRINT**/ ◀ to move left in a menu
 Press **UNITS**/ ▶ to move right in a menu
 Press **ZERO**/ ← to accept a value or choice and move up in the menu.
 Press **F1** to escape and move up in the menu

4.2 Menu annunciators

The menu structure is made up of menu items, parameters, value entry screens and lists from which you choose one item. To help you know where you are in the menu, the bargraph at the top of the display is on while the indicator is in the menus and will change appearance according to the following rules:

All segments flashing	This means you are in the menu structure but not in any of the following screens.
Center flashing / others solid	This means you are in a parameter prompt screen. See Parameter Code section.
Center flashing / others off	This means you are in a numeric or octet entry screen. Enter a number and press ZERO to accept.
Right flashing / others off	This means you are in a list. Scroll through the choices with the PRINT and UNITS keys and press ZERO to accept.

Left most solid / others off

This means you are in a screen for string or hex data entry.

4.3 Exiting the menus

1. If you are at the bottom item in a menu use **ZERO** to accept a choice or value and move up a level, or use **F1** to escape and move up one level without accepting the choice or value. From that point, press the **TARE** key repeatedly until ...

SAVE no is displayed. This means “Do not save changes.”

2. Use the **PRINT** or **UNITS** key to scroll through the choices: **SAVE no**, **SAVEYES** and **CAnCEL**. Press **Enter** to accept the displayed choice.

If you choose **SAVE no** or **SAVEYES** the indicator exits the menu and returns to normal weighing mode.

OR

If you choose **CAnCEL**, the indicator remains in the menu.

4.4 USER level menus

The USER level menus are available to the user. The other menu levels are for supervisors and technicians only.

The USER level (password 111) contains the User, About, and Audit menus arranged as shown in [Figure 4.1](#).

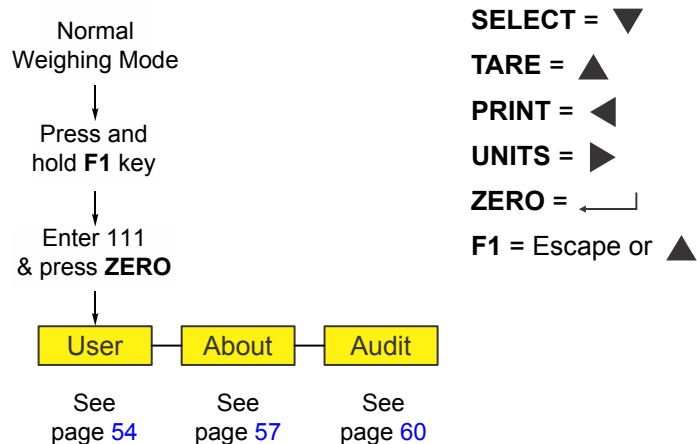

Figure 4.1 USER level (password 111) menus



Under some of the section headings you will see menu items with small arrows (↓ →). These are reminders of the menu structure and how you got to the menu item.

4.5 User menu

The User menu is shown in [Figure 4.2](#).

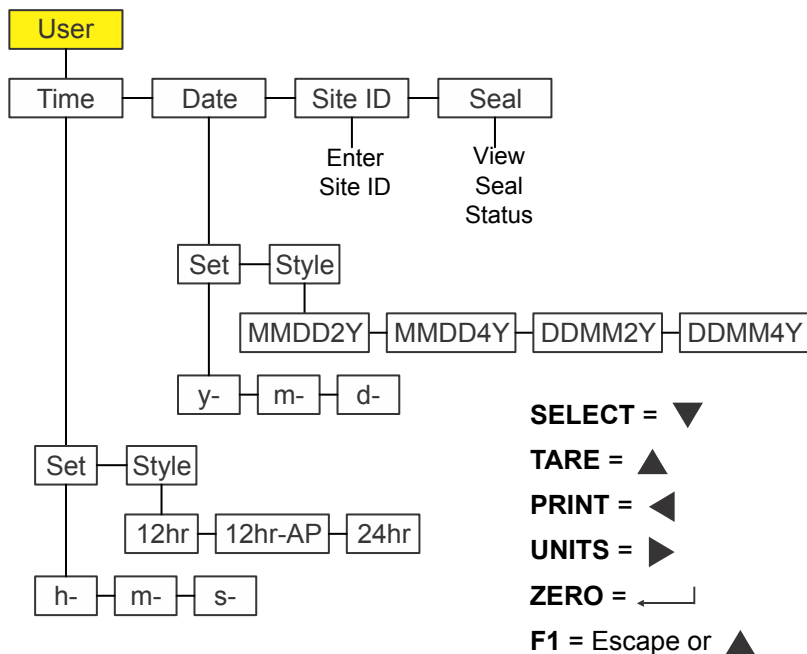

Figure 4.2 User menu



All numeric values require scroll entry. See [Numeric entry procedure on page 20](#).

Use this menu to set the time and date, to enter a site ID, and view the physical seal status. Each is explained below:

4.5.1 Time

User ↓ Time

1. Access the User menu (see [Accessing the menus on page 52](#)) and press **SELECT** ...
tiME is displayed. Use this to set the time and clock style.
2. Press **SELECT** ...
SEt is displayed.
3. Press **SELECT** ...
h- x is displayed, with the **x** flashing. This is a numeric entry screen for the hour value.

4. Key in the hour of the day using military (24 hr) time and press **ZERO** ...
The choice is made and **M- x** is displayed, with the **x** flashing. This is a numeric entry screen for the minute value.
5. Key in the minute value and press **ZERO** ...
The choice is made and **S- x** is displayed, with the **x** flashing. This is a numeric entry screen for the second value.
6. Key in the seconds value and press **ZERO** ...
The choice is made and **SEt** is displayed.
7. Press **UNITS** ...
StYLE is displayed. Use this to set the style of clock for printouts. Choices are **12hr**, **12hr-AP** (AM/PM) and **24hr** (military time).
8. Press **SELECT** ...
12hr is displayed.
9. Press **PRINT** or **UNITS** to scroll through the choices. Press **ZERO** when your choice is displayed ...
The choice is made and **StYLE** is displayed.
10. Press **TARE** ...
tiME is displayed.

4.5.2 Date

User ↓ Time → Date

1. Press **UNITS** ...
dAtE is displayed.
2. Press **SELECT** ...
SEt is displayed.
3. Press **SELECT** ...
y- x is displayed, with the **x** flashing. This is a numeric entry screen for the year value.
4. Key in the year and press **ZERO** ...
The choice is made and **M- x** is displayed, with the **x** flashing. This is a numeric entry screen for the month.
5. Key in the month value and press **ZERO** ...
The choice is made and **d- x** is displayed, with the **x** flashing. This is a numeric entry screen for the day value.
6. Key in the day value and press **ZERO** ...
The choice is made and **SEt** is displayed.

7. Press **UNITS** ...
StYLE is displayed. Use this to set the style of date for printouts.
Choices are **MMDD2Y**, **MMDD4Y**, **DDMM2Y** and **DDMM4Y**.
8. Press **SELECT** ...
MMDD2Y is displayed.
9. Press **PRINT** or **UNITS** to scroll through the choices. Press **ZERO** when your choice is displayed ...
The choice is made and **StYLE** is displayed.
10. Press **TARE** ...
dAtE is displayed.

4.5.3 Site ID

User ↓ Time → Date → Site ID

1. Press **UNITS** ...
Site id is displayed.
2. Press **SELECT** ...
A numeric entry screen is displayed.
3. Key in a site ID number on the numeric keypad and press **ZERO** to accept ...
Site id is displayed.



The Site ID can be used in transmitted or printing information. ASCII characters 32-126 can be used.

4.5.4 Seal

User ↓ Time → Date → Site ID → Seal

1. Press **UNITS** ...
SEAL is displayed.
2. Press **SELECT** ...
unSEAL or **SEALed** is displayed. This is the status of the physical seal inside the indicator. If the unit is sealed, no changes can be made to the configuration of the indicator.
3. Press **F1** to return to the **SEAL** display.
4. To exit the menu, see [Exiting the menus on page 53](#).

4.6 About menu

The About menu is shown in [Figure 4.3](#).

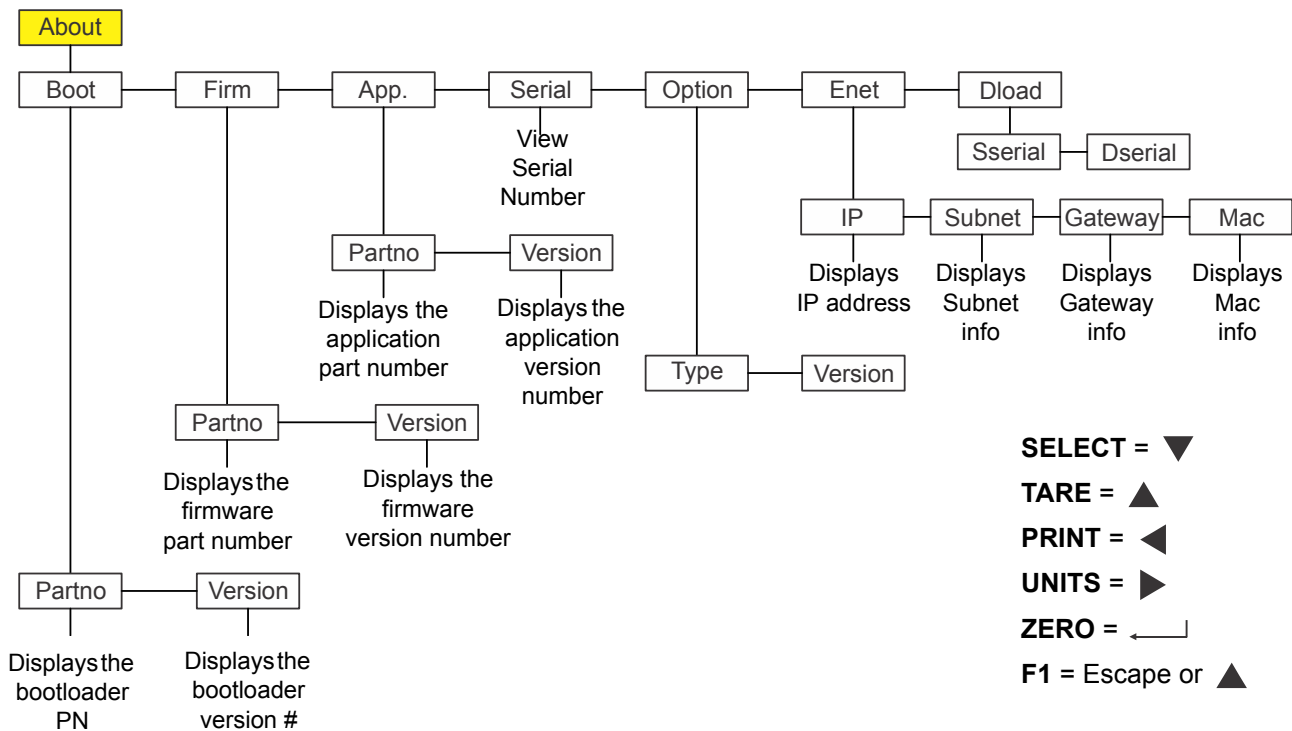

Figure 4.3 About menu

Use this menu to display information about the various items shown in [Figure 4.3](#). Each is explained below:

4.6.1 Boot

About ↓ Boot

1. Access the About menu and press **SELECT** ...
boot is displayed.
2. Press **SELECT** ...
PArtno is displayed
3. Press **SELECT** ...
The 1st half of the bootloader PN is displayed. Press **UNITS** to view the 2nd half.
4. Press **ZERO** to return to the *PArtno* display.
5. Press **PRINT** or **UNITS** to move to the other item in this level ...
VERsion is displayed.

6. Press **SELECT** ...
The version number of the bootloader is displayed.
7. Press **ZERO** to return to the **VERsion** display.
8. Press **TARE** to return to the **boot** display.

4.6.2 Firm and App

About ↓ Boot → Firm and App

1. Press **UNITS** to move to the next item in this level ...
FirM is displayed. This stands for firmware.
2. Repeat the same pattern of key presses in steps 2 through 3 to view the part number and version for the **FirM**. and **APP** menu items.

4.6.3 Serial

About ↓ Boot → Firm → App → Serial

1. With **APP** displayed, press **UNITS** to move to the next item in this level ...
SEriAL is displayed.
2. Press **SELECT** ...
The indicator's serial number is displayed.
3. Press **TARE** to return to the **SEriAL** display.

4.6.4 Option

About ↓ Boot → Firm → App → Serial → Option

1. Press **UNITS** to move to the next item in this level ...
oPtion is displayed.
2. Press **SELECT** ...
VERsion is displayed. This stands for the software revision or version of the currently installed option card. This can be useful service information.
3. To view the version, press **SELECT** ...
The software revision number is shown.
4. Press **ZERO** ...
oPtion is displayed.
5. Press **UNITS** to move to the other item in this level ...
tYPE is displayed. This stands for the type of option card installed. The four option cards are: Analog, 802.11g wireless, USB-d, and RS-485.

6. Press **SELECT** ...
The currently installed option card name is displayed.
7. Press **ZERO** ...
tYPE is displayed.
8. Press **TARE** ...
oPtion is displayed.

4.6.5 Enet

About ↓ Boot → Firm → App → Serial → Option → Enet



If the indicator is connected to an ethernet network, the values displayed will be the current assigned addresses.

1. Press **UNITS** ...
EnEt is displayed. Use this item to view the values for the IP, Subnet, Gateway and MAC addresses.
2. Press **SELECT** ...
iP is displayed. Use this item to view the four part IP address.
3. Press **SELECT** ...
0 0 is displayed. This is first portion of the IP address
4. Press **ZERO** ...
1 0 is displayed. This is second portion of the IP address.
5. Press **ZERO** ...
2 0 is displayed. This is third portion of the IP address.
6. Press **ZERO** ...
3 1 is displayed. This is fourth portion of the IP address.
7. Press **ZERO** ...
iP is displayed.
8. Press **UNITS** ...
Subnet is displayed.
9. Repeat this sequence of key presses for the **Subnet**, **Gateway** and **MAC** addresses.
10. When you are finished, from the menu item, press **TARE** to return to the **Enet** menu item.

4.6.6 Dload

About ↓ Boot → Firm → App → Serial → Option → Enet → Dload

1. From **EnEt**, press **UNITS** ...
dLoAd is displayed. This stands for download. Under **SSEriAL** you can view the serial number of the software application that created the configuration file. Under **dSSEriAL** you can view the serial number of the software application that downloaded the configuration file. This is used for security and licensing purposes.
2. Press **SELECT** ...
SSEriAL is displayed.
3. Press **SELECT** ...
 The 1st half of the serial number of the creating application of the configuration file is displayed.
4. Press **ZERO** to show the 2nd half.
5. Press **F1** ...
SSEriAL is displayed.
6. Press **UNITS** ...
dSSEriAL is displayed.
7. Press **SELECT** ...
 The 1st half of the serial number of the downloading application of the configuration file was downloaded to, is displayed.
8. Press **ZERO** to show the 2nd half.
9. Press **F1** ...
dSSEriAL is displayed.
10. Press **TARE** until **About** is displayed.
11. To exit the menu, see [Exiting the menus on page 53](#).

4.7 Audit menu

The Audit menu is shown in [Figure 4.4](#).

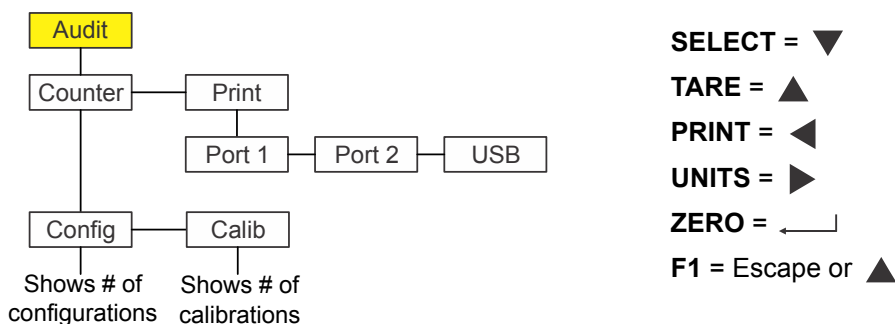

Figure 4.4 Audit menu

Use this menu to display audit counters for configuration and calibration and to print the information. Each is explained below:

4.7.1 Counter

Audit ↓ Counter

1. Access the Audit menu and press **SELECT** ...
countEr is displayed. This has two counters that tell you how many times the indicator has been configured and calibrated.
2. Press **SELECT** ...
conFig is displayed.
3. Press **SELECT** again ...
 A number appears showing how many times the indicator has been configured.
4. Press **ZERO** ...
conFig is displayed.
5. Press **UNITS** to move to the next item in this level ...
cALib is displayed.
6. Press **SELECT** ...
 A number appears showing how many times the indicator has been calibrated.
7. Press **ZERO** ...
cALib is displayed.
8. Press **TARE** ...
countEr is displayed.

4.7.2 Print

Audit ↓ Counter → Print







1. Press **UNITS** ...
Print is displayed.
2. Press **SELECT** ...
Port1 is displayed. This is the first of three choices: **Port 1**, **Port 2** or **uSb**. Use these to select which port to print the audit report through.
3. Press **PRINT** or **UNITS** to scroll through the choices and press **ZERO** when your choice is displayed ...
 The audit log is printed through the chosen port and *Print* is displayed.
4. This completes the Audit menu. To exit the menu, see [Exiting the menus on page 53](#).

5 Error messages

The following errors may be displayed during use of the indicator.

Message	Display
Overload	
Can't fit on display. In the PER375 application, this means an initial Target value is not set.	
Underload	
Can't	
Entry not in valid range	
Password entry failed	
General error. Report to repair tech.	
The indicator failed the attempted action	
Checkweigher did not reach a stable zero weight within time window set for automated weighing process.	
If this message is cycling on the display every 10 - 20 seconds, it indicates that the battery option is enabled but the checkweigher is not using a battery with the built- in power down circuitry	

5.1 PLU CSV file import error messages

Message	Display
Failed to get csv file handle	
Failed to allocate memory for csv file	
First line of csv file is invalid	
Failed to read csv file, size didn't match	
StrRowData too big	
Field count mismatch	

6 Communications

The ZQ375 can communicate through these ports:

- Serial
- Ethernet
- USB
- Wireless 802.11g

6.1 Default print formats

Below are examples of the default formats that are available. Any print format can be customized to suit your application needs please contact your Avery Weigh-Tronix representative for assistance. Additional information on print formats can be found in the Service Manual.

General Weighing (Format #1)

```
~~~~~  
Gross  272.04 lb  
Tare   95.88 lb  
Net    176.16 lb  
~~~~~
```

Trans. Count and Totals (Format #9)

```
~~~~~  
Trans #      2  
Gross Total  26.5 lb  
Net Total    26.5 lb  
~~~~~
```

Under/Over/Accept (Format #24)

```
~~~~~  
Accept:      176.16 lb  
~~~~~
```

Accept/Reject (Format #25)

```
~~~~~  
Reject:      142 lb  
~~~~~
```

Net Weighment w/Band (Format #27)

```
~~~~~  
3.601 lb OVER  
~~~~~
```

Standard Deviation (Format #28)

```

Tolerance Hi = 0.650 lb
Tolerance Lo = 0.150 lb

Cnt of Over Wt = 3
Cnt of Under Wt = 6
Cnt of Target Wt = 3
Mean Net Wt = 0.073 lb
Max Net Wt = 0.879 lb
Min Net Wt = 0.00 lb
SD Net Wt = 0.254
CV Net Wt = 3.464 PCT
Cnt of Tot Wt = 12

```

X-Bar/R (Format #29)

```

TARGET HI = 2.650 lb
TARGET LO = 1.850 lb

MEAN NET WT= 1.512 lb
MEDIAN NET WT= 1.518 lb

```

Grading (Format #30)

```

Grad3 6.005 lb

```

The ZQ375 can be configured for many other outputs to match the application. Refer to the Service manual for full details on available print formats.

7 Supervisor menu

This menu allows a supervisor to change those functions of an application that are configurable. Access the supervisor menu using the password 1793. Refer to [Accessing the menus on page 52](#) for instructions.

The Supervisor menu changes based on the active application. Each is shown on the following pages.

- [Supervisor menu for Sim375 application on page 67](#)
- [Supervisor menu for Mid375 application on page 74](#)
- [Supervisor menu for Adv375 application on page 82](#)
- [Supervisor menu for Per375 application on page 93](#)
- [Supervisor menu for the Grad375 application on page 95](#)

Below is a chart showing how the keys are used in navigating through the menus. There is an abbreviated version in next to each menu as a reminder of the key functions.

Menu Navigation Keys:

<p>Press SELECT/ ▼ to move down in a menu</p> <p>Press TARE/ ▲ to move up in a menu, except at the bottom item in a menu, then use ZERO/ ← or F1</p> <p>Press PRINT/ ◀ to move left in a menu</p> <p>Press UNITS/ to move right in a menu</p> <p>Press ZERO/ ← to accept a value or choice and move up in the menu.</p> <p>Press F1 to escape and move up in the menu</p>

7.1 Supervisor menu for Sim375 application

This section applies if the Sim375 application is active. The Sim375 Supervisor menu is shown in Figure 7.1.

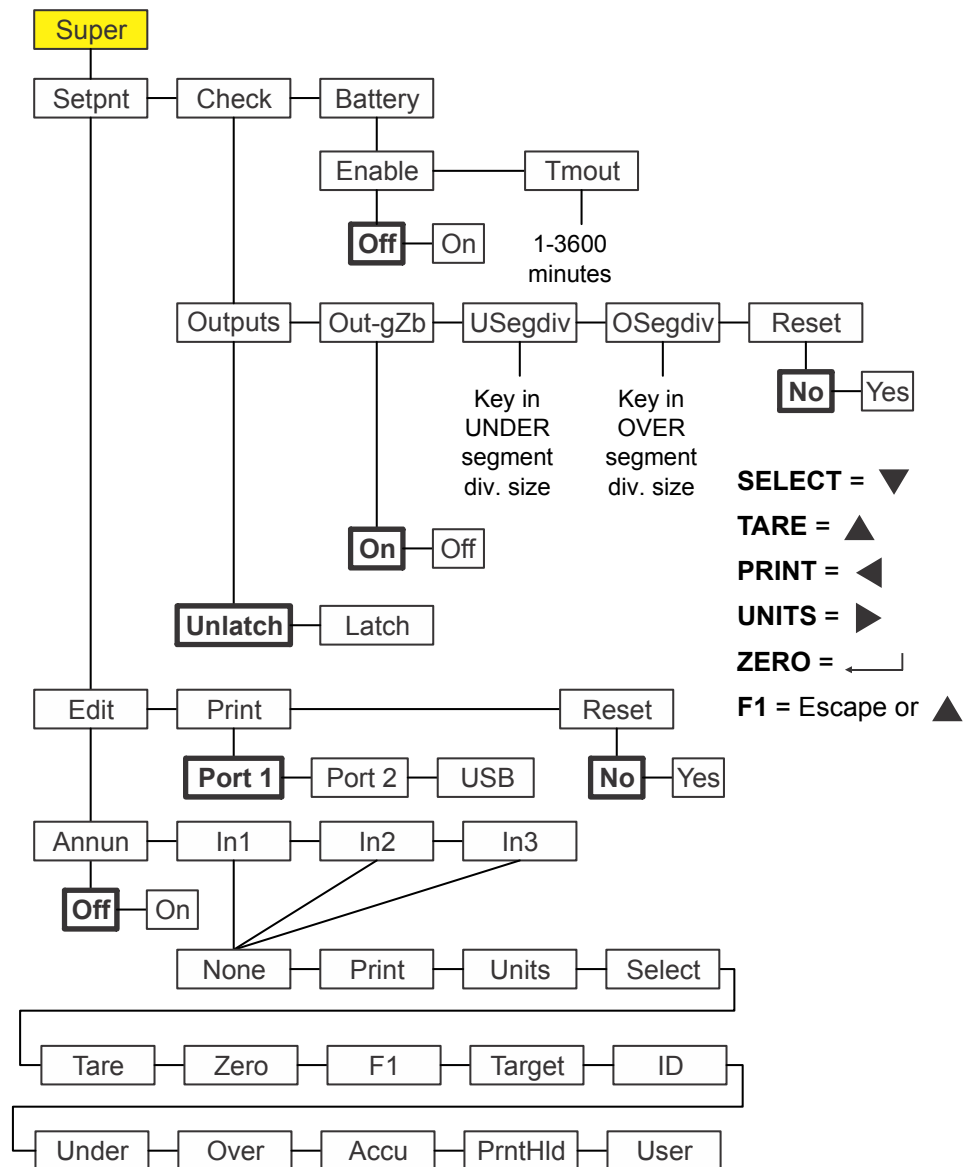

Figure 7.1 Sim375 Supervisor menu



All numeric values require scroll entry. See [Numeric entry procedure on page 20](#).

Follow these steps to use the Supervisor menu:

Access the Supervisor menu (password 1793). See [Accessing the menus on page 52](#).

7.1.1 Setpoint

Super↓ Setpoint

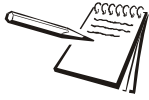

The ↓ and → symbols stand for direction moved in the menu. So Super ↓ Setpoint illustrates that you move down from **Super** to **Setpoint**. This will help you keep track of where you are in the menu structure.



The Setpoint menu is the same for all the applications so will only be explained once here.

1. From **SuPEr**, press **SELECT** ...

SEtPnt is displayed. Use this to:

- set the function of the setpoint annunciators
- select inputs for up to three inputs
- print the setpoint settings
- reset all setpoint settings to factory defaults.

Annunciators

Setpoint ↓ Edit ↓ Annun

2. Press **SELECT** ...

Edit is displayed.

3. Press **SELECT** ...

Annun is displayed. This stands for annunciators, referring to the *SP1*, *SP2* and *SP3* setpoint annunciators. .By default (**oFF**) these annunciators follow the condition of the checkweigh fan graph. If Under then *SP1* is on, if Accept then *SP2* is on, If Over then *SP3* is on. If ANNUN is set to ON it will invert these conditions. Setting ANNUN to ON is not a typical usage for checkweighing.

4. Press **SELECT** ...

The current setting is displayed (**oFF** or **on**).

5. Press **PRINT** or **UNITS** to toggle between the choices and when your choice is displayed, press **ZERO** to accept ...

Annun is displayed.

Inputs

Setpoint ↓ Edit ↓ Annun → Inputs

6. Press **UNITS** ...

in1 is displayed. This stands for input 1. Use this to assign a function to input 1 when an external switch is tripped. Default choice is **none**. The choices are listed in [Figure 7.1](#). Some may not apply in this application.



The remote input can be used to perform an accumulated print total function. Use the **PrintHoLd** function to simulate a “press and hold” of the **PRINT** key. If you are using a momentary switch, press and release. If you are using a toggle switch, switch it **ON** then **OFF** to reset the function for the next time.

7. From **in1**, press **SELECT** ...

The current choice is displayed.

8. Press **PRINT** or **UNITS** to scroll through the choices and when your choice is displayed, press **ZERO** to accept ...

in1 is displayed.

9. Press **UNITS** ...

in2 is displayed.

10. Repeat steps 7 through 9 for **in2** and **in3**. Press **TARE** when finished ...

Edit is displayed.

Print

Setpoint ↓ Edit → Print

11. Press **UNITS** ...

Print is displayed. Use this to print the settings under **SEtPnt**.

12. Press **SELECT** ...

Port 1 is displayed.

13. Press **F1** to abort the print process or press **UNITS** to scroll to the desired port and press **ZERO** to print the information ...

Print is displayed after either action.

Reset

Setpoint ↓ Edit → Print → Reset

14. Press **UNITS** ...

rESEt is displayed. Use this to reset the settings under **Edit** to factory defaults.

15. Press **SELECT** ...
no is displayed.
16. Press **ZERO** to abort the reset or press **UNITS** ...
YES is displayed.
17. Press **ZERO** to reset the settings to factory defaults ...
rESEt is displayed.
18. Press **TARE** ...
SEtPnt is displayed.

7.1.2 Check

Super ↓ Setpoint → Check

1. From **tArE** press **UNITS** ...
chEcK is displayed. This is the checkweighing configuration item. Under this you can:
 - Set the outputs to be latched or unlatched
 - Enable output-gross zero band (out-gZb)
 - Set the under and over segment division size
 - Reset all the checkweighing items to factory defaults.Follow the steps below.

Outputs

Check ↓ Outputs

2. From **chEcK**, press **SELECT** ...
outPutS is displayed. There are two choices for outputs, **LAtch** and **unLAtch** (default). If you choose **LAtch**, this means that weights will have to stabilize at or above the output value before the relay or annunciator changes. If you choose **unLAtch**, the relay and annunciator will change instantly as the weight swings above and below the output value.
3. From **outPutS**, press **SELECT** ...
The current choice is displayed.
4. Press **PRINT** or **UNITS** to toggle between the choices and when your choice is displayed, press **ZERO** to accept ...
outPutS is displayed.

Output-gross zero band

Check ↓ Outputs → Out-gzb

5. Press **UNITS** to go to the next menu item ...

out-gZb is displayed. This stands for output-gross zero band. You can set outputs to **on** (default) while the weight is in the gross zero band or set them to **oFF** while the weight is in the gross zero band.

6. Press **SELECT** ...

The current choice is displayed.

7. Press **PRINT** or **UNITS** to toggle between the choices and when your choice is displayed, press **ZERO** to accept ...

out-gZb is displayed.

Under segment division

Check ↓ Outputs → Out-gzb → USegDiv

8. Press **UNITS** to go to the next menu item ...

uSEgdiV is displayed. This stands for under-segment division size. Choose how many divisions are equal to one segment on the *UNDER* display bargraph. You can key in a value from 1 to 1000 divisions per segment.



All numeric values require scroll entry. See [Numeric entry procedure on page 20](#).

9. Press **SELECT** ...

The current value is displayed.

10. Key in a new value and press **ZERO** to accept ...

uSEgdiV is displayed.

Over segment division

Check ↓ Outputs → Out-gzb → USegDiv → OSegDiv

11. Press **UNITS** to go to the next menu item ...

oSEgdiV is displayed. This stands for over-segment division size. Choose how many divisions are equal to one segment on the *OVER* display bargraph. You can key in a value from 1 to 1000 divisions per segment.

12. Press **SELECT** ...

The current value is displayed.

13. Key in a new value and press **ZERO** to accept ...

oSEgdiV is displayed.

Reset

Check ↓ Outputs → Out-gzb → USegDiv → OSegDiv → Reset

14. Press **UNITS** to go to the next menu item ...
rESEt is displayed. Use this to reset the factory defaults for the checkweighing parameters.
15. Press **SELECT** ...
no is displayed. This is the default value.
16. Press **ZERO** to abort the reset or, to reset the defaults, press **UNITS** ...
YES is displayed. Accepting this will reset the defaults.
17. Press **ZERO** to accept ...
The defaults are reset and *rESEt* is displayed.
18. Press **TARE** ...
chEcK is displayed.

7.1.3 Battery

Super ↓ Setpoint → Tare → Battery



The Battery menu is the same for all the applications so will only be explained once here.

1. Press **UNITS** to go to the next menu item ...
bAttErY is displayed. Use this to enable the battery and to set a timeout length (in minutes). If this time expires with no scale or keypad activity, the battery will be shut off.

Enable

Battery ↓ Enable

2. Press **SELECT** ...
EnAbLE is displayed. Choices are **OFF** (default) and **on**. Choose **OFF** to disable battery usage. Choose **on** to enable battery usage.

3. Press **PRINT** or **UNITS** to toggle between the choices and when your choice is displayed, press **ZERO** to accept ...

EnAbLE is displayed.



*Only enable the battery and set the **tMout** value if the ZQ-BAT option is being used. If battery use is enabled, setpoint output 3 cannot be used for setpoints in checkweighing applications. It is used as a shutoff signal to the ZQ-BAT battery option.*

Non ZQ-BAT supplied power may require external shut off circuitry. See the Service Manual for information on this feature.

Timeout

Battery ↓ Enable → Timeout

4. Press **UNITS** to go to the next menu item ...

tMout is displayed. Use this to set the length of time before inactivity on the scale and keypad cause battery power to be shutoff. Values between 1 and 3600 minutes are valid. Default value is 60 minutes.
5. Press **SELECT** ...

A numeric entry screen appears.
6. Use the [Numeric entry procedure on page 20](#) to key an a value, in minutes and press **ZERO** to accept ...

tMout is displayed.
7. This completes the Supervisor menu for the Sim375 application. Repeatedly press **TARE** to return to normal operating mode.

7.2 Supervisor menu for Mid375 application

This section applies if the Mid375 application is active. The Mid375 Supervisor menu is shown in Figure 7.2.

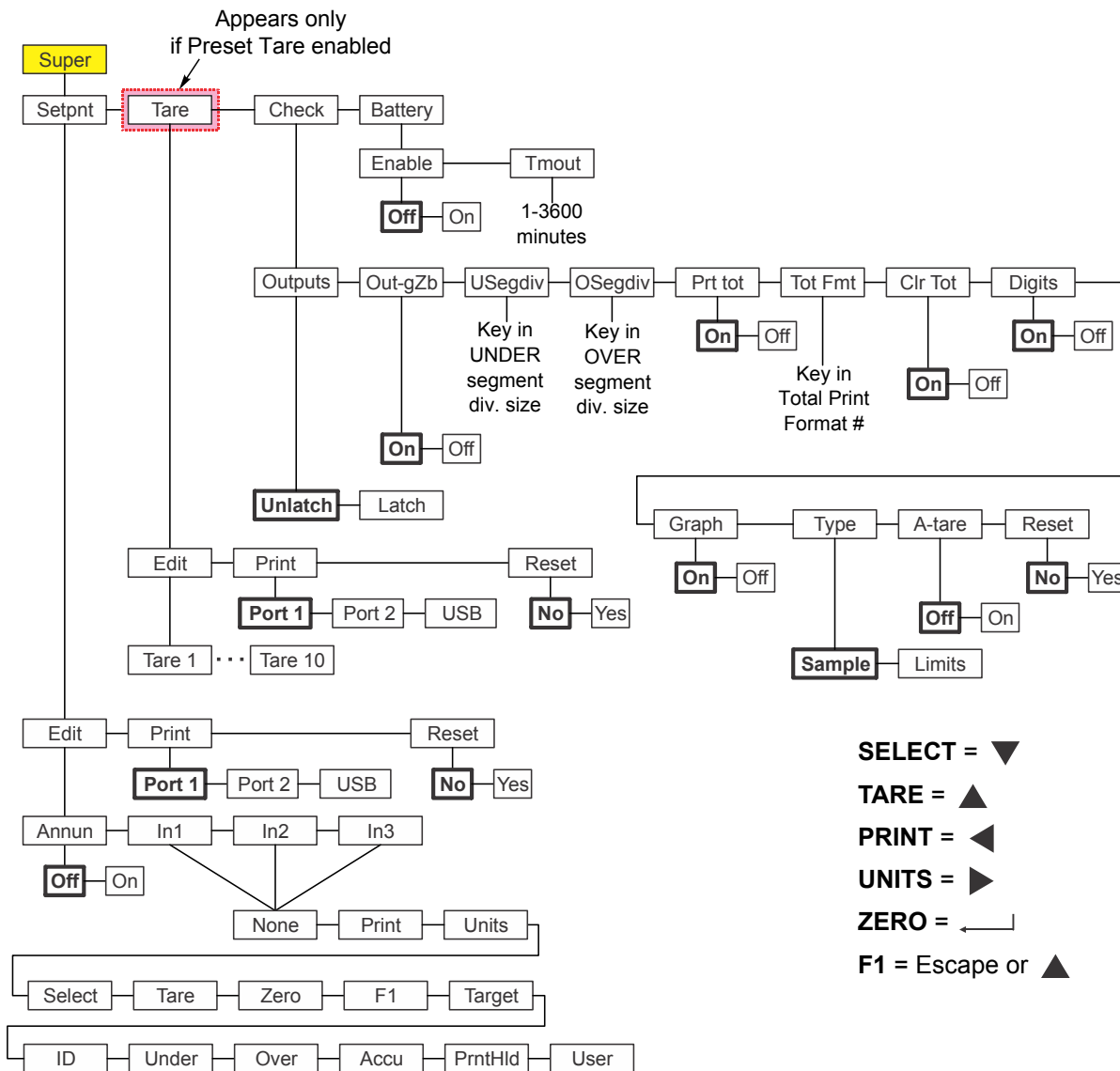

Figure 7.2 Mid375 Supervisor menu



All numeric values require scroll entry. See [Numeric entry procedure on page 20](#).

Follow these steps to use the Supervisor menu:

Access the Supervisor menu (password 1793). See [Accessing the menus on page 52](#).

7.2.1 Setpoint

Super ↓ Setpoint

The Setpoint menu is the same in all the applications. See [Setpoint on page 68](#).

7.2.2 Tare

Super ↓ Setpoint → Tare



The Tare menu is the same in any application that it appears so will only be explained once here. It appears only if Preset Tare is configured in a password protected menu.

1. From **SEtPnt** press **UNITS ...**

tArE is displayed.

Use this to:

- set values for up to 10 preset tares
- print the values of the preset tares
- reset all preset tares to factory defaults of 0

The following steps describe the procedures.

Tare Register 1-10

Tare ↓ Edit ↓ Tare 1-10

2. Press **SELECT ...**

Edit is displayed.

3. Press **SELECT ...**

tArE 1 is displayed. This is the first of the 10 preset tare values you can set.

4. Press **SELECT ...**

The current value is displayed with a flashing right digit.

5. Press **ZERO** to accept the displayed value or key in a new value and press **ZERO** to accept ...

tArE 1 is displayed.

6. Press **UNITS ...**

tArE 2 is displayed.

7. Repeat steps 4 through 6 for **tArE 2** through **tArE 10**. Press **TARE** when finished ...

Edit is displayed.



If the active unit of measure is lb-oz then tare weights must be entered in the oz equivalent. To enter 2 lb 4.5 oz you would need to enter 36.5 oz (2 lb = 32 oz plus the 4.5)

Printing

Tare ↓ Edit → Print

8. Press **UNITS** ...

Print is displayed. Use this to print the preset tare values.

9. Press **SELECT** ...

Port 1 is displayed.

10. Press **F1** to abort the print process or press **UNITS** to scroll to the desired port and press **ZERO** to print the information ...

Print is displayed after either action.

Reset

Tare ↓ Edit → Print → Reset

11. Press **UNITS** ...

rESet is displayed. Use this to reset all the preset tares to the factory default of 0.

12. Press **SELECT** ...

no is displayed. **no** is the default.

13. Press **ZERO** to abort the reset or press **UNITS** ...

YES is displayed.

14. Press **ZERO** to reset the settings to factory defaults ...

rESet is displayed.

15. Press **TARE** ...

tArE is displayed.

7.2.3 Check

Super ↓ Setpoint → Tare → Check

1. From **tArE** press **UNITS** ...

chEcK is displayed. This is the checkweighing configuration item. Under this you can:

- Set the outputs to be latched or unlatched
- Enable outputs on or off in gross zero band
- Set the under and over segment division size
- Turn weight digits on or off during checkweighing
- Turn the bargraph on or off during checkweighing
- Set the type of checkweighing: Limits or Sample
- Reset all the checkweighing items to factory defaults.

Follow the steps below.

Outputs

Check ↓ Outputs

2. From **chEck**, press **SELECT** ...

outPutS is displayed. There are two choices for outputs, **LAtch** and **unLAtch** (default). If you choose **LAtch**, this means that weights will have to stabilize at or above the output value before the relay or annunciator changes. If you choose **unLAtch**, the relay and annunciator will change instantly as the weight swings above and below the output value.

3. From **outPutS**, press **SELECT** ...

The current choice is displayed, **LAtch** or **unLAtch**.

4. Press **PRINT** or **UNITS** to toggle between the choices and when your choice is displayed, press **ZERO** to accept ...

outPutS is displayed.

Output-gross zero band

Check ↓ Outputs → Out-gzb

5. Press **UNITS** to go to the next menu item ...

out-gZb is displayed. This stands for output-gross zero band. You can set outputs to **on** (default) while the weight is in the gross zero band or set them to **oFF** while the weight is in the gross zero band.

6. Press **SELECT** ...

The current choice is displayed.

7. Press **PRINT** or **UNITS** to toggle between the choices and when your choice is displayed, press **ZERO** to accept ...

out-gZb is displayed.

Under segment division

Check ↓ Outputs → Out-gzb → USegDiv

8. Press **UNITS** to go to the next menu item ...

uSEgdiV is displayed. This stands for under-segment division size. Choose how many divisions are equal to one segment on the *UNDER* display bargraph. You can key in a value from 1 to 1000 divisions per segment. 1 is the default value.



All numeric values require scroll entry. See [Numeric entry procedure on page 20](#).

9. Press **SELECT** ...

The current value is displayed.

10. Key in a new value and press **ZERO** to accept ...

uSEgdiV is displayed.

Over segment division

Check ↓ Outputs → Out-gzb → USegDiv → OSegDiv

11. Press **UNITS** to go to the next menu item ...

oSEgdiV is displayed. This stands for over-segment division size. Choose how many divisions are equal to one segment on the *OVER* display bargraph. You can key in a value from 1 to 1000 divisions per segment. 1 is the default value.

12. Press **SELECT** ...

The current value is displayed.

13. Key in a new value and press **ZERO** to accept ...

oSEgdiV is displayed.

Print total

Check ↓ Outputs → Out-gzb → USegDiv → OSegDiv → Prt tot

14. Press **UNITS** to go to the next menu item ...

Prt tot is displayed. Use this to enable/disable printing of the Total report. Choose **on** (default) to enable and **off** to disable this function.

15. Press **SELECT** ...

The current choice is displayed.

16. Press **PRINT** or **UNITS** to toggle between the choices and when your choice is displayed, press **ZERO** to accept ...

Prt tot is displayed.

Total format

Check ↓ Outputs → Out-gzb → USegDiv → OSegDiv → Prt tot → Tot Fmt



To print the Total format for the MID375 application you must either perform a reset (see [Reset on page 81](#)), which sets the Total format to 9 or manually key in 9 under the Total format menu item.

17. Press **UNITS** to go to the next menu item ...

tot Fmt is displayed. Use this to choose a print format for the Total report.

18. Press **SELECT** ...

The current print format number is displayed.

19. Press **ZERO** to accept this or use the [Numeric entry procedure on page 20](#) to enter a new print format number and press **ZERO** to accept ...

tot Fmt is displayed.

Clear total

Check ↓ Outputs → Out-gzb → USegDiv → OSegDiv → Prt tot → Tot Fmt
→ Clr Tot

20. Press **UNITS** to go to the next menu item ...

cLr tot is displayed. Use this to enable or disable the clearing of the transaction counter. Choose **on** (default) to enable and **off** to disable the clearing of the transaction counter.

21. Press **SELECT** ...

The current choice is displayed.

22. Press **PRINT** or **UNITS** to toggle between the choices and when your choice is displayed, press **ZERO** to accept ...

cLr tot is displayed.

Digits

Check ↓ Outputs → Out-gzb → USegDiv → OSegDiv → Prt tot → Tot Fmt
→ Clr Tot → Digits

23. Press **UNITS** to go to the next menu item ...

digitS is displayed. Use this to turn the weight display **off** or **on** (default) when in checkweighing mode. When set to **off** the bargraph is the only part of the display that is on.

24. Press **SELECT** ...

The current choice is displayed.

25. Press **PRINT** or **UNITS** to toggle between the choices and when your choice is displayed, press **ZERO** to accept ...

digitS is displayed.

Graph

Check ↓ Outputs → Out-gzb → USegDiv → OSegDiv → Prt tot → Tot Fmt
→ Clr Tot → Digits → Graph

26. Press **UNITS** to go to the next menu item ...

grAPh is displayed. Use this to turn the graph display **OFF** or **on** (default) when in checkweighing mode. When set to **OFF** the weight digits are the only part of the display that is on.

27. Press **SELECT** ...

The current choice is displayed.

28. Press **PRINT** or **UNITS** to toggle between the choices and when your choice is displayed, press **ZERO** to accept ...

grAPh is displayed.

Type

Check ↓ Outputs → Out-gzb → USegDiv → OSegDiv → Prt tot → Tot Fmt
→ Clr Tot → Digits → Graph → Type

29. Press **UNITS** to go to the next menu item ...

TYPE is displayed. Use this to choose which type of checkweighing you want to do: **SAMPLE** or **LiMitS**.

Select **SAMPLE** mode (default) if you want to enter a target weight by placing a sample on the scale and pressing the **TARGET** key. The upper and is automatically set to +1 division and the lower tolerance is automatically set to -1 division.

Select **LiMitS** mode to enter an upper and lower limit which defines the acceptable weight range.

30. Press **SELECT** ...

The current choice is displayed.

31. Press **PRINT** or **UNITS** to toggle between the choices and when your choice is displayed, press **ZERO** to accept ...

TYPE is displayed.

Auto Tare

Check ↓ Outputs → Out-gzb → USegDiv → OSegDiv → Prt tot → Tot Fmt
→ Clr Tot → Digits → Graph → Type → A-tare

32. Press **UNITS** to go to the next menu item ...

A-tArE is displayed. Use this to disable or enable (**oFF** (default) or **on**) an auto tare when the target weight is reached. This allows you to add items to a box or pallet and auto-tare the weight of each item if it falls in the target range.

33. Press **SELECT** ...

The current choice is displayed.

34. Press **PRINT** or **UNITS** to toggle between the choices and when your choice is displayed, press **ZERO** to accept ...

A-tArE is displayed.

Reset

Check ↓ Outputs → Out-gzb → USegDiv → OSegDiv → Prt tot → Tot Fmt
→ Clr Tot → Digits → Graph → Type → A-tare → Reset

35. Press **UNITS** to go to the next menu item ...

rESEt is displayed. Use this to reset the factory defaults for the checkweighing parameters.

36. Press **SELECT** ...

no is displayed. This is the default value.

37. Press **ZERO** to abort the reset or, to reset the defaults, press **UNITS** ...

YES is displayed. Accepting this will reset the defaults.

38. Press **ZERO** to accept ...

The defaults are reset and **rESEt** is displayed.

39. Press **TARE** ...

chEcK is displayed.

7.2.4 Battery

Super ↓ Setpoint → Tare → Check → Battery

The Battery menu is the same in all the applications. See [Battery on page 72](#).

This completes the Supervisor menu for the Mid375 application. Repeatedly press **TARE** to return to normal operating mode.

7.3 Supervisor menu for Adv375 application

This section applies if the Adv375 application is active. The Supervisor menu is shown in Figure 7.3.

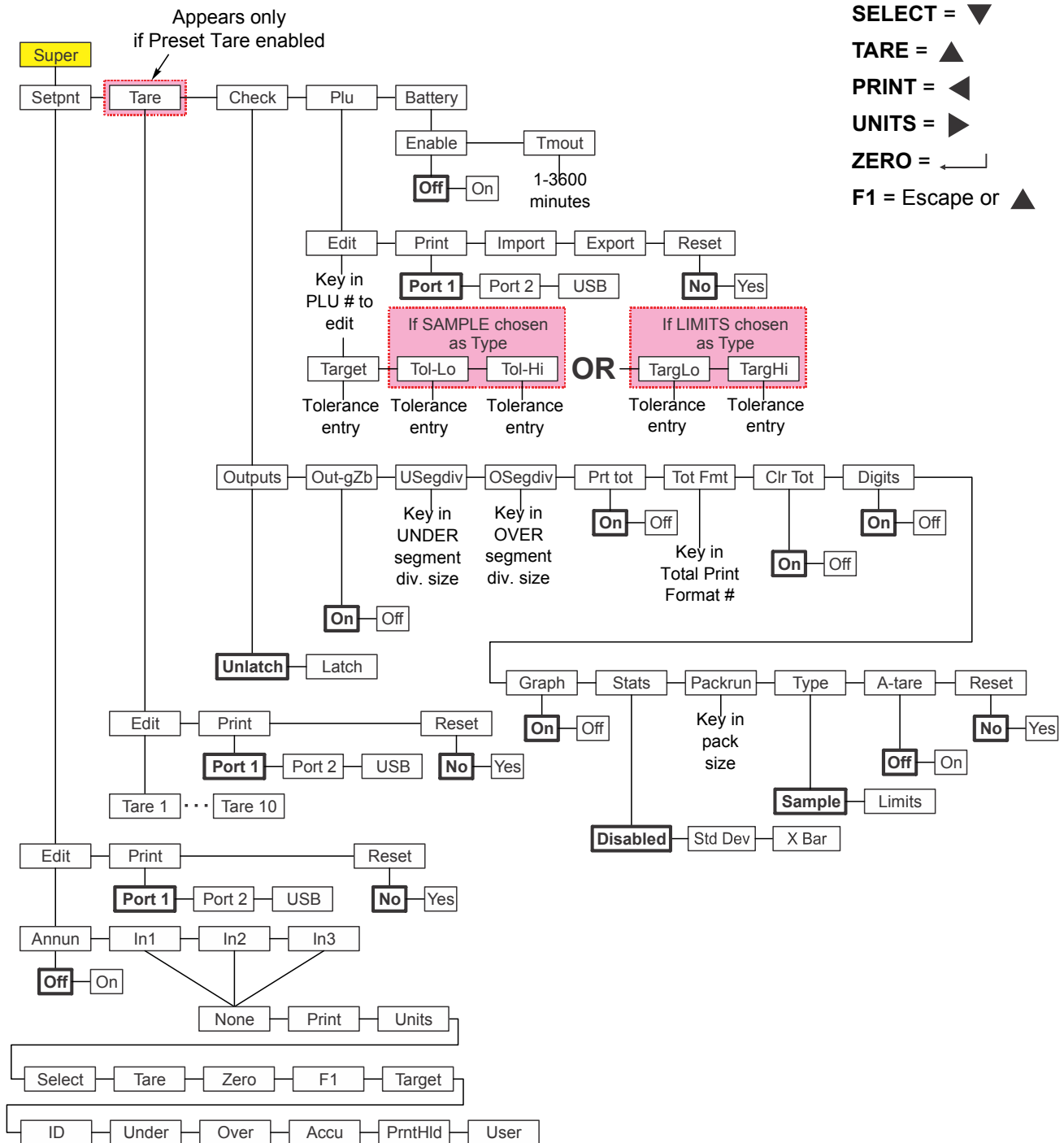

Figure 7.3 Supervisor menu for Adv375 applications



All numeric values require scroll entry. See [Numeric entry procedure on page 20](#).

Follow these steps to use the Supervisor menu:

Access the Supervisor menu (password 1793). See [Accessing the menus on page 52](#).

7.3.1 Setpoint

Super ↓ Setpoint

The Setpoint menu is the same in all the applications. See [Setpoint on page 68](#).

7.3.2 Tare

Super ↓ Setpoint → Tare

The Tare menu is the same in all the applications. See [Tare on page 75](#).

7.3.3 Check

Super ↓ Setpoint → Tare → Check

1. From **SEtPoint** press **UNITS** ...

chEcK is displayed. This is the checkweighing configuration item. Under this you can:

- Set the outputs to be latched or unlatched
- Enable outputs on or off in gross zero band
- Set the under and over segment division size
- Enable/disable printing of the total in a packrun
- Choose the total print format number
- Enable/disable clearing the total after a packrun
- Turn weight digits on or off during checkweighing
- Turn checkweighing graph on or off during checkweighing
- Enable/disable Standard Deviation calculation on a packrun
- Choose the number of weighments in a packrun
- Set the type of checkweighing: Limits or Sample
- Enable/disable auto tare when target weight is reached
- Reset all the checkweighing items to factory defaults.

Follow the steps below.

Outputs

Check ↓ Outputs

- From **chEcK**, press **SELECT ...**

outPutS is displayed. There are two choices for outputs, **LAtch** and **unLAtch** (default). If you choose **LAtch**, this means that weights will have to stabilize at or above the output value before the relay or annunciator changes. If you choose **unLAtch**, the relay and annunciator will change instantly as the weight swings above and below the output value.

- From **outPutS**, press **SELECT ...**

The current choice is displayed, **LAtch** or **unLAtch**.

- Press **PRINT** or **UNITS** to toggle between the choices and when your choice is displayed, press **ZERO** to accept ...

outPutS is displayed.

Outputs-gross zero band

Check ↓ Outputs → Out-gzb

- Press **UNITS** to go to the next menu item ...

out-gZb is displayed. This stands for output-gross zero band. You can set outputs to **on** (default) while the weight is in the gross zero band or set them to **oFF** while the weight is in the gross zero band.

- Press **SELECT ...**

The current choice is displayed.

- Press **PRINT** or **UNITS** to toggle between the choices and when your choice is displayed, press **ZERO** to accept ...

out-gZb is displayed.

Under segment division

Check ↓ Outputs → Out-gzb → USegDiv

- Press **UNITS** to go to the next menu item ...

uSEgdiV is displayed. This stands for under-segment division size. Choose how many divisions are equal to one segment on the **UNDER** display bargraph. You can key in a value from 1 to 1000 divisions per segment. 1 is the default value.

- Press **SELECT ...**

The current value is displayed.

10. Key in a new value and press **ZERO** to accept ...

uSEgdiV is displayed.

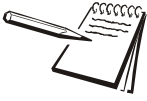

All numeric values require scroll entry. See [Numeric entry procedure on page 20](#).

Over segment division

Check ↓ Outputs → Out-gzb → USegDiv → OSegDiv

11. Press **UNITS** to go to the next menu item ...

oSEgdiV is displayed. This stands for over-segment division size. Choose how many divisions are equal to one segment on the *OVER* display bargraph. You can key in a value from 1 to 1000 divisions per segment. 1 is the default value.

12. Press **SELECT** ...

The current value is displayed.

13. Key in a new value and press **ZERO** to accept ...

oSEgdiV is displayed.

Print total

Check ↓ Outputs → Out-gzb → USegDiv → OSegDiv → Prt tot

14. Press **UNITS** to go to the next menu item ...

Prt tot is displayed. Use this to enable/disable printing of the total packrun information. Choose **on** (default) to enable and **off** to disable this function.

15. Press **SELECT** ...

The current choice is displayed.

16. Press **PRINT** or **UNITS** to toggle between the choices and when your choice is displayed, press **ZERO** to accept ...

Prt tot is displayed.

Total format

Check ↓ Outputs → Out-gzb → USegDiv → OSegDiv → Prt tot → Tot Fmt

17. Press **UNITS** to go to the next menu item ...

tot Fmt is displayed. Use this to choose a print format for the Total report of the packrun.



The Total Report for the pack run can be customized to present statistical data of your choosing. This information is found in the Service manual.

18. Press **SELECT** ...

The current print format number is displayed.

19. Press **ZERO** to accept this or use the [Numeric entry procedure on page 20](#) to enter a new print format number and press **ZERO** to accept ...

tot Fmt is displayed.

Clear total

Check ↓ Outputs → Out-gzb → USegDiv → OSegDiv → Prt tot → Tot Fmt
→ Clr Tot

20. Press **UNITS** to go to the next menu item ...

cLr tot is displayed. Use this to enable or disable the clearing of the total packrun information. Choose **on** (default) to enable and **oFF** to disable the clearing of the information.

21. Press **SELECT** ...

The current choice is displayed.

22. Press **PRINT** or **UNITS** to toggle between the choices and when your choice is displayed, press **ZERO** to accept ...

cLr tot is displayed.

Digits

Check ↓ Outputs → Out-gzb → USegDiv → OSegDiv → Prt tot → Tot Fmt
→ Clr Tot → Digits

23. Press **UNITS** to go to the next menu item ...

digitS is displayed. Use this to turn the weight display **on** (default) or **oFF** when in checkweighing mode. When set to **oFF** the bargraph is the only part of the display that is on.

24. Press **SELECT** ...

The current choice is displayed.

25. Press **PRINT** or **UNITS** to toggle between the choices and when your choice is displayed, press **ZERO** to accept ...

digitS is displayed.

Graph

Check ↓ Outputs → Out-gzb → USegDiv → OSegDiv → Prt tot → Tot Fmt
→ Clr Tot → Digits → Graph

26. Press **UNITS** to go to the next menu item ...

grAPh is displayed. Use this to turn the graph display **oFF** or **on** (default) when in checkweighing mode. When set to **oFF** the weight digits are the only part of the display that is on.

27. Press **SELECT** ...

The current choice is displayed.

28. Press **PRINT** or **UNITS** to toggle between the choices and when your choice is displayed, press **ZERO** to accept ...

grAPh is displayed.

Stats

Check ↓ Outputs → Out-gzb → USegDiv → OSegDiv → Prt tot → Tot Fmt
→ Clr Tot → Digits → Graph → Stats

29. Press **UNITS** to go to the next menu item ...

StAtS is displayed. Use this to enable or disable the standard deviation statistical program, the X-Bar/R program or to disable **StAtS**.

If you choose **Std dEV**, the standard deviation will be calculated after a packrun is complete.

If you choose **X bAr**, the trend of the last eight weighments will be reported in a printout. For more information see [X-Bar/R Program on page 45](#).



The Reported Printout for the pack run can be customized to present statistical data of your choosing. This information is found in the Service Manual.

If you choose **diSAbLEd**, no statistical information will be calculated. This is the default choice.

30. Press **SELECT** ...

The current choice is displayed.

31. Press **PRINT** or **UNITS** to toggle between the choices and when your choice is displayed, press **ZERO** to accept ...

StAtS is displayed.

Packrun

Check ↓ Outputs → Out-gzb → USegDiv → OSegDiv → Prt tot → Tot Fmt
→ Clr Tot → Digits → Graph → Stats → Packrun

32. Press **UNITS** to go to the next menu item ...

PAcKrun is displayed. Use this to set the number of items in the packrun.

33. Press **SELECT** ...

The current packrun number is displayed.

34. Press **ZERO** to accept this or use the [Numeric entry procedure on page 20](#) to enter a new packrun number and press **ZERO** to accept ...

PAcKrun is displayed.

Type

Check ↓ Outputs → Out-gzb → USegDiv → OSegDiv → Prt tot → Tot Fmt
→ Clr Tot → Digits → Graph → Stats → Packrun → Type

35. Press **UNITS** to go to the next menu item ...

TYPE is displayed. Use this to choose which type of checkweighing you want to do: **SAMPLE** (default) or **LiMitS**.

Select **SAMPLE** mode (default) if you want to enter the Toler-Hi and Toler-Lo and target weight in the PLU editor.

Select **LiMitS** if you want to enter the targ-lo and targ-hi and target values.

36. Press **SELECT** ...

The current choice is displayed.

37. Press **PRINT** or **UNITS** to toggle between the choices and when your choice is displayed, press **ZERO** to accept ...

TYPE is displayed.

Auto Tare

Check ↓ Outputs → Out-gzb → USegDiv → OSegDiv → Prt tot → Tot Fmt
→ Clr Tot → Digits → Graph → Stats → Packrun → Type → A-tare

38. Press **UNITS** to go to the next menu item ...

A-tArE is displayed. Use this to disable or enable (**oFF** (default) or **oN**) an auto tare when the target weight is reached. This allows you to add items to a box or pallet and auto-tare the weight of each item if it falls in the target range.

39. Press **SELECT** ...

The current choice is displayed.

40. Press **PRINT** or **UNITS** to toggle between the choices and when your choice is displayed, press **ZERO** to accept ...

A-tArE is displayed.

Reset

Check ↓ Outputs → Out-gzb → USegDiv → OSegDiv → Prt tot → Tot Fmt
→ Clr Tot → Digits → Graph → Stats → Packrun → Type → A-tare → Reset

41. Press **UNITS** to go to the next menu item ...

rESEt is displayed. Use this to reset the factory defaults for the checkweighing parameters.

42. Press **SELECT** ...

no is displayed. This is the default value.

43. Press **ZERO** to abort the reset or, to reset the defaults, press **UNITS** ...

YES is displayed. Accepting this will reset the defaults.

44. Press **ZERO** to accept ...

The defaults are reset and **rESEt** is displayed.

45. Press **TARE** ...

chEcK is displayed.

7.3.4 PLU

Super ↓ Setpoint → Tare → Check → Plu

1. Press **UNITS** to go to the next menu item ...

PLu is displayed. This stand for Product Look Up. Use this to edit the PLU list, print the list or reset the PLUs to factory defaults.

PLUs consist of a sequential number as an identifier, a target weight, a target-low weight and a target-high weight.



When doing negative checkweighing, you must enter the target weight as a negative value in the PLU. Target-high and target-low values are still entered as positive values.

Edit

PLU ↓ Edit

2. Press **SELECT** ...

Edit is displayed. Use this item to setup the PLU list.

3. Press **SELECT** ...

A numeric entry screen appears with a flashing **0**.

4. Use the [Numeric entry procedure on page 20](#) to enter the PLU number you wish to create or edit and press **ZERO** to accept ...

tArGEt is displayed. Use this to set the target weight.



If you are editing an existing PLU, the tolerance and target values displayed will be the values stored in the PLU.

If you are creating a new PLU, default values will be displayed.

5. Press **SELECT** ...

The current value of the net weight on the scale platform is displayed. This is done so that you can use the actual product assigned to this specific PLU number to establish the target weight without having to manually enter the value.

6. Press **ZERO** to accept this value or use the [Numeric entry procedure on page 20](#) to enter the target weight and press **ZERO** to accept ...

tArgEt is displayed.

7. Press **UNITS** to go to the next menu item ...

If **SAMPLE** mode is chosen as checkweighing type, **toL-Lo** is displayed.

If **LiMitS** mode is chosen as checkweighing type, **tArgLo** is displayed.

Use either to set the lowest weight that is still acceptable--the Target or Tolerance Low weight.

8. Press **SELECT** ...

A default value appears with a flashing rightmost digit. If this is the **tArgLo** value, the displayed value will be the current net weight on the scale minus one division. If this is the **toL-Lo** value, the displayed value will be the current division size.

9. Use the [Numeric entry procedure on page 20](#) to enter the value and press **ZERO** to accept ...

toL-Lo or **tArgLo** is displayed.

10. Press **UNITS** to go to the next menu item ...

If **SAMPLE** mode is chosen as checkweighing type, **toL-hi** is displayed.

If **LiMitS** mode is chosen as checkweighing type, **tArghi** is displayed.

Use either to set the highest weight that is still acceptable--the Target or Tolerance High weight.

11. Press **SELECT** ...

A default value appears with a flashing rightmost digit. If this is the **tArghi** value, the displayed value will be the current net weight on the scale plus one division. If this is the **toL-hi** value, the displayed value will be the current division size.

12. Use the [Numeric entry procedure on page 20](#) to enter the target high weight and press **ZERO** to accept ...

toL-hi or **tArghi** is displayed.

13. Press **TARE** ...

Edit is displayed.

Print

PLU ↓ Edit → Print

14. Press **UNITS** to go to the next menu item ...

Print is displayed. Use this to print the PLU information.

15. Press **SELECT** ...

Port 1 is displayed.

16. Press **F1** to abort the print process or press **UNITS** to scroll to the desired port and press **ZERO** to print the information ...

Print is displayed after either action.

Import

PLU ↓ Edit → Print → Import

17. Press **UNITS** ...

iMPort is displayed. Use this to import a .CSV (comma separated value) file of PLU values from a plugged in USB thumbdrive. This will overwrite any existing PLU values.



The USB drive **MUST** be plugged in before you enter the Supervisor menu for the **iMPort** and **EXPort** commands to work.

To insure that the CSV file format to Import is acceptable do the following: Create at least one PLU using PLU>EDIT, then Export to the USB thumbdrive.

Open the file using Excel and copy and paste the row containing the PLU values into the number of rows necessary. Edit changes to the PLUNumber (1-500) and the target and tolerance values for Sample mode or the target high and low values for Limits mode as needed. Then save the file on the thumbdrive and Import back into the indicator. See [PLU CSV file import error messages on page 63](#).

18. With **iMPort** displayed, press **SELECT** to import the file ...

buSY and **donE** are briefly displayed as the .CSV file is imported and the old PLU values are overwritten. **iMPort** is displayed when finished.

Export

PLU ↓ Edit → Print → Import → Export

19. Press **UNITS** ...

EXPort is displayed. Use this to export the current PLU settings to a .CSV file in a connected USB thumbdrive.

20. With **EXPort** displayed, press **SELECT** to export the file ...

buSY and **donE** are briefly displayed as the .CSV file is exported to the USB drive. **EXPort** is displayed when finished.

Reset

PLU ↓ Edit → Print → Import → Export → Reset

21. Press **UNITS** ...

rESet is displayed. Use this to reset the accumulation channels and associated data.

22. Press **SELECT** ...

no is displayed. This is the default choice.

23. With **no** displayed, press **ZERO** to abort the reset action or press **UNITS** to toggle to **YES** and press **ZERO** to reset the information ...

rESet is displayed after either action.

24. Press **TARE** ...

PLu is displayed.

7.3.5 Battery

Super ↓ Setpoint → Tare → Check → Plu → Battery

The Battery menu is the same in all the applications. See [Battery on page 72](#).

This completes the Supervisor menu for the Adv375 application. Repeatedly press **TARE** to return to normal operating mode.

Access the Supervisor menu (password 1793). See [Accessing the menus on page 52](#).



All numeric values require scroll entry. See [Numeric entry procedure on page 20](#).

7.4.1 Setpoint

Super ↓ Setpoint

The Setpoint menu is the same in all the applications. See [Setpoint on page 68](#).

7.4.2 Tare

Super ↓ Setpoint → Tare

The Tare menu is the same in all the applications. See [Tare on page 75](#).

7.4.3 Check

Super ↓ Setpoint → Tare → Check

The Check menu is the same as the Check menu in the Adv375 application with one exception: A-tare (auto tare) is not available in the Per375 application. See [Check on page 83](#).

7.4.4 PLU

Super ↓ Setpoint → Tare → Check → Plu

The PLU menu is the same as the PLU menu in the Adv375 application. See [PLU on page 89](#).

7.4.5 Battery

Super ↓ Setpoint → Tare → Check → Plu → Battery

The Battery menu is the same in all the applications. See [Battery on page 72](#).

7.5 Supervisor menu for the Grad375 application

This section applies if the Grad375 application is active. The Grad375 Supervisor menu is shown in Figure 7.5.

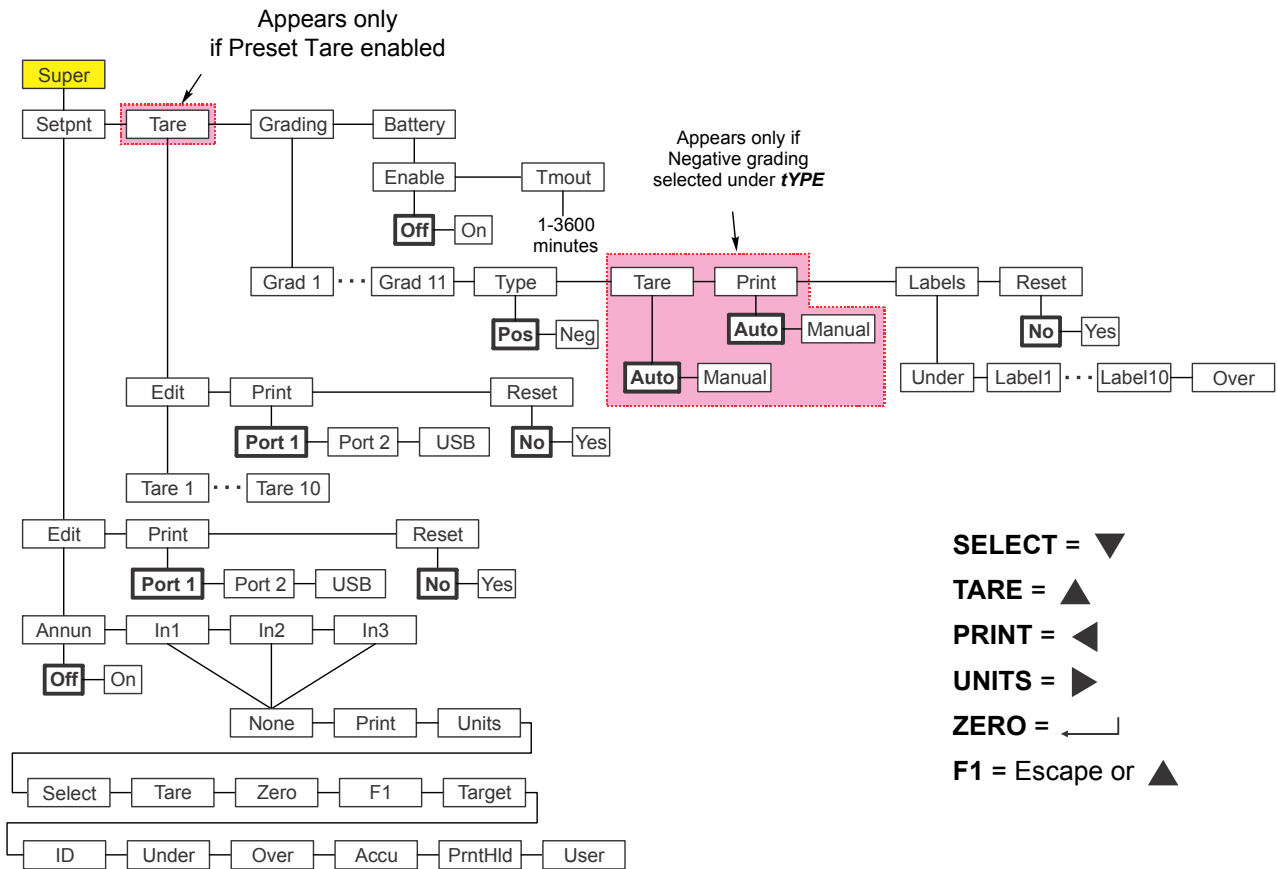

Figure 7.5 Supervisor menu for the Grad375 application



All numeric values require scroll entry. See [Numeric entry procedure on page 20](#).

7.5.1 Setpoint

Super ↓ Setpoint

The Setpoint menu is the same in all the applications. See [Setpoint on page 68](#).

7.5.2 Tare

Super ↓ Setpoint → Tare

The Tare menu is the same in all the applications. See [Tare on page 75](#).

7.5.3 Grading

Super ↓ Setpoint → Tare → Grading

Use Grading to set the weight points that define up to 10 weight grades. Follow the process found in [Setting weight grades on page 49](#).

After the last weight point is set there is another item called **tYPE**. Under this are two choices: **PoS** or **nEg**. Positive is the default and operates as described in [Positive grading on page 50](#). If you choose **nEg**, refer to [Negative grading with autotare enabled on page 50](#) for instructions.

If negative grading is chosen, two more items appear after **tYPE**: **tArE** and **Print**. Under each Auto (default) or Manual can be chosen.

Auto Tare If you choose auto tare the scale will tare automatically after each item is removed from the tote.

Manual Tare If you choose manual tare the user will need to press the **TARE** key after the grade is displayed to continue the process.

Auto Print If you choose auto print the print format associated with a **PRINT** key press will be performed automatically after each item is graded.

Manual Print If you choose manual print the print format associated with a **PRINT** key press will be performed if the user presses the **PRINT** key.



The 'grading' token must be used in the print format for the print function to report the correct weight.

If negative grading is or isn't chosen, there are two more menu items: Labels and Reset, explained below.

Labels

This item allows you to put in a string of characters which are used to print a custom label for the weight grade. For example, instead of a simple **Grad1** label, you could have **Small** as the printout.

1. From Labels, press **SELECT**...

undEr appears. Use this to create a label for all weights under Grade Point #1.

2. Press **SELECT**...

A string entry screen is displayed. Refer to [String index/character data entry on page 21](#) for instructions on entering a new label string.



The custom label will be shown on the display when doing grading. The label can be seven characters long, maximum. ASCII characters 32-126 can be used.

3. When finished entering the custom label characters, press **ENTER** to accept ...

The display returns to the item you were customizing.

4. Press **UNITS** to move to the next label you want to customize. Repeat the steps to customize each label. The list is shown in [Figure 7.5](#).

5. When finished with labels, press **TARE** and ...

LABELS is displayed.

6. Press **UNITS** and ...

rESEt is displayed.

Reset

Use this to reset the application settings back to factory default. This does not affect calibration or other scale configurations.

1. From **rESEt**, press **SELECT** ...

no is displayed. This is the default value.

2. Press **ZERO** to abort the reset or, to reset the defaults, press **UNITS** ...

YES is displayed. Accepting this will reset the defaults.

3. Press **ZERO** to accept ...

The defaults are reset and **rESEt** is displayed.

4. Press **TARE** ...

GrAdinG is displayed.

7.5.4 Battery

Super ↓ Setpoint → Tare → Grading → Battery

The Battery menu is the same in all the applications. See [Battery on page 72](#).

This completes the Supervisor menu for the Grad375 application. Repeatedly press **TARE** to return to normal operating mode.

Avery Weigh-Tronix



Avery Weigh-Tronix USA

1000 Armstrong Dr.
Fairmont MN 56031 USA
Tel:507-238-4461
Fax:507-238-4195
Email: usinfo@awtxglobal.com
www.averyweigh-tronix.com

Avery Weigh-Tronix UK

Foundry Lane,
Smethwick, West Midlands,
England B66 2LP
Tel:+44 (0) 8453 66 77 88
Fax:+44 (0)121 224 8183
Email: info@awtxglobal.com
www.averyweigh-tronix.com