

ZM305 Standard Indicator



User Instructions

Avery Weigh-Tronix is a trademark of the Illinois Tool Works group of companies whose ultimate parent company is Illinois Tool Works Inc ("Illinois Tool Works"). Copyright © 2014 Illinois Tool Works. All rights reserved.

No part of this publication may be reproduced by making a facsimile copy, by the making of a copy in three dimensions of a two-dimensional work and the making of a copy in two dimensions of a three-dimensional work, stored in any medium by electronic means, or transmitted in any form or by any means, including electronic, mechanical, broadcasting, recording or otherwise without the prior written consent of the copyright owner, under license, or as permitted by law.

This publication was correct at the time of going to print, however Avery Weigh-Tronix reserves the right to alter without notice the specification, design, price or conditions of supply of any product or service at any time.

Table of Contents

	<i>page</i>
Table of Contents	3
Chapter 1 General information and warnings	5
About this manual	5
Text conventions	5
Special messages	5
Installation	5
Safe handling of equipment with batteries	6
Wet conditions	6
Routine maintenance	6
Cleaning the machine	7
Training	7
Sharp objects	7
FCC and EMC declarations of compliance	8
Declarations of Conformity	9
Chapter 2 Introduction	11
Front panel	11
Annunciators	13
Powering up the ZM305	14
Entering a negative number	14
Chapter 3 Indicator applications	15
General weighing application	15
SELECT key default function	15
Gross weighing	15
Net weighing	16
Using setpoints	18
Printing	20
ID Entry	20
Accumulator application	21
SELECT key default function	21
Special key functions	21
Accumulator operation	21
Counting application	23
SELECT key default function	23
Special key functions	23
Sample operation	23
Dribble sampling	23
Bulk sampling	24
Piece weight entry	25
Checkweighing application	26
SELECT key default function	26
Special key functions	26
Checkweigh operation	26
Weighing a target object	27
Setting upper and lower limits	27
Setpoint operation in the checkweighing application	28
Batching application	29
SELECT key default function	29
Special key functions	29
Batching operation	30

2-Speed filling	30
Ingredient filling	30
Independent setpoints	31
Fill/Discharge	31
Peak hold application	32
SELECT key default function	32
Special key functions	32
Peak hold operation	32
Remote display application	33
In-Motion application	34
SELECT key operation	34
Chapter 4 Menus	35
Accessing the menus	35
Menu annunciators	35
Exiting the menus	36
USER level menus	36
User menu	37
Time	37
Date	38
Site ID	39
Seal	39
About menu	40
Boot	40
Firm and App	41
Serial	41
Option	41
Enet	42
Dload	43
Audit menu	44
Counter	44
Print	45
Chapter 5 Communications	46
Default print formats	46
Chapter 6 Error messages	48
Chapter 7 Supervisor menu	49
General Weighing application supervisor menu	50
Setpoint	51
Tare	54
Battery	56
Accumulator application supervisor menu	58
Accumulator	59
Counting application supervisor menu	62
Count	62
Checkweighing application supervisor menu	66
Check	67
Batching application supervisor menu	69
Setpoint	69
Batch	72
Notes on batching	75
Peak Hold application supervisor menu	77
Peak hold	77
Remote Display application supervisor menu	79
In-Motion application supervisor menu	81
In-Motion	82

1 General information and warnings

1.1 About this manual

This manual is divided into chapters by the chapter number and the large text at the top of a page. Subsections are labeled as shown by the 1.1 and 1.1.1 headings. The names of the chapter and the next subsection level appear at the top of alternating pages of the manual to remind you of where you are in the manual. The manual name and page numbers appear at the bottom of the pages.

1.1.1 Text conventions

Key names are shown in **bold** and reflect the case of the key being described. If a key has a dual function it may be referred to by its alternate function.

Displayed messages appear in ***bold italic*** type and reflect the case of the displayed message.

Annunciator names appear as *italic* text and reflect the case of the annunciator.

1.1.2 Special messages

Examples of special messages you will see in this manual are defined below. The signal words have specific meanings to alert you to additional information or the relative level of hazard.



CAUTION!

This is a Caution symbol.

Cautions give information about procedures that, if not observed, could result in damage to equipment or corruption to and loss of data.



NOTE: *This is a Note symbol. Notes give additional and important information, hints and tips that help you to use your product.*

1.2 Installation



NO USER SERVICEABLE PARTS. REFER TO QUALIFIED SERVICE PERSONNEL FOR SERVICE.

1.2.1 Safe handling of equipment with batteries



CAUTION: *Danger of explosion if battery is incorrectly replaced. Replace only with the same or equivalent type recommended by the manufacturer. Dispose of used batteries according to the manufacturer's instructions.*

ATTENTION: *Il y a danger d'explosion s'il y a remplacement incorrect de la batterie, remplacer uniquement avec une batterie du même type ou d'un type équivalent recommandé par le constructeur. Mettre au rebut les batteries usagées conformément aux instructions du fabricant.*

1.2.2 Wet conditions

Under wet conditions, the plug must be connected to the final branch circuit via an appropriate socket / receptacle designed for washdown use.

Installations within the USA should use a cover that meets NEMA 3R specifications as required by the National Electrical Code under section 410-57. This allows the unit to be plugged in with a rain tight cover fitted over the plug.

Installations within Europe must use a socket which provides a minimum of IP56 protection to the plug / cable assembly. Care must be taken to make sure that the degree of protection provided by the socket is suitable for the environment.

1.3 Routine maintenance



IMPORTANT: *This equipment must be routinely checked for proper operation and calibration. Application and usage will determine the frequency of calibration required for safe operation.*

Always isolate the indicator from the power supply before starting any routine maintenance to avoid the possibility of electric shock.

1.4 Cleaning the machine

Table 1.1 Cleaning DOs and DON'Ts

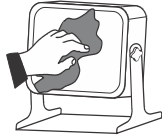

DO	DO NOT
Wipe down the outside of standard products with a clean cloth, moistened with water and a small amount of mild detergent	Attempt to clean the inside of the machine
	Use harsh abrasives, solvents, scouring cleaners or alkaline cleaning solutions
Spray the cloth when using a proprietary cleaning fluid	Spray any liquid directly on to the display windows

1.5 Training

Do not attempt to operate or complete any procedure on a machine unless you have received the appropriate training or read the instruction books.

To avoid the risk of RSI (Repetitive Strain Injury), place the machine on a surface which is ergonomically satisfactory to the user. Take frequent breaks during prolonged usage.

1.6 Sharp objects

Do not use sharp objects such as screwdrivers or long fingernails to operate the keys.

1.7 FCC and EMC declarations of compliance

United States

This equipment has been tested and found to comply with the limits for a Class A digital device, pursuant to Part 15 of the FCC Rules. These limits are designed to provide reasonable protection against harmful interference when the equipment is operated in a commercial environment. This equipment generates, uses, and can radiate radio frequency energy and, if not installed and used in accordance with the instruction manual, may cause harmful interference to radio communications. Operation of this equipment in a residential area is likely to cause harmful interference in which case the user will be required to correct the interference at his own expense.

Canada

This digital apparatus does not exceed the Class A limits for radio noise emissions from digital apparatus set out in the Radio Interference Regulations of the Canadian Department of Communications.

Le présent appareil numérique n'émet pas de bruits radioélectriques dépassant les limites applicables aux appareils numériques de la Classe A prescrites dans le Règlement sur le brouillage radioélectrique édicté par le ministère des Communications du Canada.

European Countries

WARNING: This is a Class A product. In a domestic environment, this product may cause radio interference in which the user may be required to take adequate measures.

1.8 Declarations of Conformity

Avery Weigh-Tronix

Foundry Lane, Smethwick, West Midlands B66 2LP, England

	Declaration of Conformity	Konformitätserklärung
	Verklaring van Overeenstemming	Dichiarazione di conformità
	Déclaration de Conformité	Declaración de Conformidad

Manufacturer Type	Avery Weigh-Tronix ZM305
No. of EC type approval certificate	UK 2923
corresponds to the requirements of the following EC directives:	
EMC Directive	2004/108/EC
Low Voltage Directive	2006/95/EC
Non-Automatic Weighing Instruments Directive	2009/23/EC ¹
The applicable harmonised standards are:	
EN 45501 : 1994 EN 60950-1 : 2006 +A12:2011	EN61000-6-4:2007
<p>Note 1: This declaration is only valid if the non-automatic weighing instrument was verified by the manufacturer or with a certificate of conformity issued by a notified body.</p> <p>ITW Ltd trading as Avery Weigh-Tronix Foundry Lane, Smethwick, West Midlands, B66 2LP, England</p> <p>Reg. Office: Admiral House, St Leonards Road, Berkshire SL4 3BL, England Registered in England No. 00559693</p>	

Fabrikant Type	Avery Weigh-Tronix ZM305
Nummer van de Verklaring van EG-typegoedkeuring	UK 2923
is in overeenstemming met de voorschriften van de volgende EG richtlijnen:	
EMC Richtlijn	2004/108/EG
Laagspanningsrichtlijn	2006/95/EG
Richtlijn niet-automatische weegwerktuigen	2009/23/EG ¹
Toegepaste geharmoniseerde normen:	
EN 45501 : 1994 EN 60950-1 : 2006 +A12:2011	EN61000-6-4:2007
<p>Noot 1: Deze verklaring is alleen geldig indien het weegwerktuig door de fabrikant is geverifieerd, of met een Verklaring van overeenstemming, afgegeven door een bevoegde instantie.</p> <p>ITW Ltd trading as Avery Weigh-Tronix Foundry Lane, Smethwick, West Midlands, B66 2LP, England</p> <p>Reg. Office: Admiral House, St Leonards Road, Berkshire SL4 3BL, England Registered in England No. 00559693</p>	

Fabricant Type	Avery Weigh-Tronix ZM305
No. de certificat d'approbation de type CE	UK 2923
correspond aux exigences des directives CE suivantes :	
Directive CEM	2004/108/CE
Directive Basse Tension	2006/95/CE
Directive pour les instruments de pesage à fonctionnement non automatique	2009/23/CE ¹
Les normes harmonisées applicables sont :	
EN 45501 : 1994 EN 60950-1 : 2006 +A12:2011	EN61000-6-4:2007
<p>Nota 1: Cette déclaration est valide seulement si l'instrument de pesage à fonctionnement non automatique a été vérifié par le fabricant ou avec une attestation de conformité délivrée par un organisme notifié.</p> <p>ITW Ltd trading as Avery Weigh-Tronix Foundry Lane, Smethwick, West Midlands, B66 2LP, England</p> <p>Reg. Office: Admiral House, St Leonards Road, Berkshire SL4 3BL, England Registered in England No. 00559693</p>	

Hersteller Typ	Avery Weigh-Tronix ZM305
Nr. der EG-Bauartzulassung	UK 2923
entspricht den Anforderungen folgender EG-Richtlinien:	
EMV-Richtlinie	2004/108/EG
Niederspannungs Richtlinie	2006/95/EG
Waagenrichtlinie für nichtselbsttätige Waagen	2009/23/EG ¹
Die angewendeten harmonisierten Normen sind:	
EN 45501 : 1994 EN 60950-1 : 2006 +A12:2011	EN61000-6-4:2007
<p>Anmerkung 1: Diese Erklärung gilt nur, wenn die nichtselbsttätige Waage vom Hersteller geeicht wurde oder in Verbindung mit einer Konformitätsbescheinigung einer benannten Stelle.</p> <p>ITW Ltd trading as Avery Weigh-Tronix Foundry Lane, Smethwick, West Midlands, B66 2LP, England</p> <p>Reg. Office: Admiral House, St Leonards Road, Berkshire SL4 3BL, England Registered in England No. 00559693</p>	

Produttore Modello	Avery Weigh-Tronix ZM305
N. di certificato di approvazione di tipo CE	UK 2923
è conforme alle caratteristiche previste dalle seguenti direttive CE:	
Normativa EMC	2004/108/CE
Normativa per la bassa tensione	2006/95/CE
Normativa per strumenti di pesatura non automatici	2009/23/CE ¹
Le norme standard armonizzate e nazionali applicate sono:	
EN 45501 : 1994 EN 60950-1 : 2006 +A12:2011	EN61000-6-4:2007
<p>Nota 1: Questa dichiarazione è valida solamente se lo strumento di pesatura non automatico è stato verificato dal produttore o provvisto di un certificato di conformità rilasciato da un ente riconosciuto.</p> <p>ITW Ltd trading as Avery Weigh-Tronix Foundry Lane, Smethwick, West Midlands, B66 2LP, England</p> <p>Reg. Office: Admiral House, St Leonards Road, Berkshire SL4 3BL, England Registered in England No. 00559693</p>	

Fabricante Tipo	Avery Weigh-Tronix ZM305
Número del certificado de aprobación de tipo CE	UK 2923
conforme a las exigencias de las siguientes directivas CE:	
Directiva CME	2004/108/CE
Directiva de baja tensión	2006/95/CE
Directiva para equipos de pesaje no automáticos	2009/23/CE ¹
Las normas armonizadas en vigor son:	
EN 45501 : 1994 EN 60950-1 : 2006 +A12:2011	EN61000-6-4:2007
<p>Nota 1: Esta declaración es válida solamente si el equipo de pesaje no automático ha sido verificado por el fabricante o con certificado de conformidad emitido por un organismo notificado.</p> <p>ITW Ltd trading as Avery Weigh-Tronix Foundry Lane, Smethwick, West Midlands, B66 2LP, England</p> <p>Reg. Office: Admiral House, St Leonards Road, Berkshire SL4 3BL, England Registered in England No. 00559693</p>	

Signature/Name Handtekening/Naam Signature/Nom Unterschrift/Name Firma/Nome Firma/Nombre		Authorised signatory for Avery Weigh-Tronix Namens van Avery Weigh-Tronix Signataire autorisé d'Avery Weigh-Tronix Unterschriftsberechtigter für Avery Weigh-Tronix Firmatario autorizzato per Avery Weigh-Tronix Firmante autorizado para Avery Weigh-Tronix	Date Datum Date Datum Data Fecha
	K. Detert Global Head of R&D		30 June 2014

76501-390 Issue 1

Avery Weigh-Tronix

Foundry Lane, Smethwick, West Midlands B66 2LP, England

	Declaration of Conformity	Konformitätserklärung
	Verklaring van Overeenstemming	Dichiarazione di conformità
	Déclaration de Conformité	Declaración de Conformidad

Manufacturer	Avery Weigh-Tronix
Type	ZM305 Automatic Gravimetric Filling Instrument
No. of EC type approval certificate	UK/0126/0122
corresponds to the requirements of the following EC directives:	
Measuring Instruments Directive	2004/22/EC
EMC Directive	2004/108/EC
Low Voltage Directive	2006/95/EC
The applicable harmonised standards are:	
OIML R61 EN 60950-1 : 2006 +A12:2011	EN 61000-6-4:2007
ITW Ltd trading as Avery Weigh-Tronix Foundry Lane, Smethwick, West Midlands, B66 2LP, England Reg. Office: Admiral House, St Leonards Road, Berkshire SL4 3BL, England Registered in England No. 00559693	

Fabrikant	Avery Weigh-Tronix
Type	ZM305 Automatic Gravimetric Filling Instrument
Nummer van de EG-onderzoeks certificaat	UK/0126/0122
is in overeenstemming met de voorschriften van de volgende EG richtlijnen:	
Richtlijn betreffende meetinstrumenten	2004/22/EG
EMC Richtlijn	2004/108/EG
Laagspanningsrichtlijn	2006/95/EG
Toegepaste geharmoniseerde normen:	
OIML R61 EN 60950-1 : 2006 +A12:2011	EN 61000-6-4:2007
ITW Ltd trading as Avery Weigh-Tronix Foundry Lane, Smethwick, West Midlands, B66 2LP, England Reg. Office: Admiral House, St Leonards Road, Berkshire SL4 3BL, England Registered in England No. 00559693	

Fabricant	Avery Weigh-Tronix
Type	ZM305 Automatic Gravimetric Filling Instrument
No. de certificat d'approbation de type CE	UK/0126/0122
correspond aux exigences des directives CE suivantes :	
Directive relative aux instruments de mesure	2004/22/CE
Directive CEM	2004/108/CE
Directive Basse Tension	2006/95/CE
Les normes harmonisées applicables sont :	
OIML R61 EN 60950-1 : 2006 +A12:2011	EN 61000-6-4:2007
ITW Ltd trading as Avery Weigh-Tronix Foundry Lane, Smethwick, West Midlands, B66 2LP, England Reg. Office: Admiral House, St Leonards Road, Berkshire SL4 3BL, England Registered in England No. 00559693	

Hersteller	Avery Weigh-Tronix
Typ	ZM305 Automatic Gravimetric Filling Instrument
Nr. der EG-Bauartprüfscheins	UK/0126/0122
entspricht den Anforderungen folgender EG-Richtlinien:	
Richtlinie für Messgeräte	2004/22/EG
EMV-Richtlinie	2004/108/EG
Niederspannungs Richtlinie	2006/95/EG
Die angewendeten harmonisierten Normen sind:	
OIML R61 EN 60950-1 : 2006 +A12:2011	EN 61000-6-4:2007
ITW Ltd trading as Avery Weigh-Tronix Foundry Lane, Smethwick, West Midlands, B66 2LP, England Reg. Office: Admiral House, St Leonards Road, Berkshire SL4 3BL, England Registered in England No. 00559693	

Produttore	Avery Weigh-Tronix
Modello	ZM305 Automatic Gravimetric Filling Instrument
N. di certificato di approvazione di tipo CE	UK/0126/0122
è conforme alle caratteristiche previste dalle seguenti direttive CE:	
Direttiva relativa agli strumenti di misura	2004/22/CE
Normativa EMC	2004/108/CE
Normativa per la bassa tensione	2006/95/CE
Le norme standard armonizzate e nazionali applicate sono:	
OIML R61 EN 60950-1 : 2006 +A12:2011	EN 61000-6-4:2007
ITW Ltd trading as Avery Weigh-Tronix Foundry Lane, Smethwick, West Midlands, B66 2LP, England Reg. Office: Admiral House, St Leonards Road, Berkshire SL4 3BL, England Registered in England No. 00559693	

Fabricante	Avery Weigh-Tronix
Tipo	ZM305 Automatic Gravimetric Filling Instrument
Número del certificado de aprobación de tipo CE	UK/0126/0122
conforme a las exigencias de las siguientes directivas CE:	
Directiva relativa a los instrumentos de medida	2004/22/CE
Directiva CME	2004/108/CE
Directiva de baja tensión	2006/95/CE
Las normas armonizadas en vigor son:	
OIML R61 EN 60950-1 : 2006 +A12:2011	EN 61000-6-4:2007
ITW Ltd trading as Avery Weigh-Tronix Foundry Lane, Smethwick, West Midlands, B66 2LP, England Reg. Office: Admiral House, St Leonards Road, Berkshire SL4 3BL, England Registered in England No. 00559693	

Signature/Name Handtekening/Naam Signature/Nom Unterschrift/Name Firma/Nombre Firma/Nombre	 K. Detert Global Head of R&D	Authorised signatory for Avery Weigh-Tronix Namens van Avery Weigh-Tronix Signataire autorisé d'Avery Weigh-Tronix Unterschriftsberechtigter für Avery Weigh-Tronix Firmatario autorizzato per Avery Weigh-Tronix Firmante autorizado para Avery Weigh-Tronix	Date Datum Date Datum Data Fecha
		30 June 2014	

2 Introduction

The ZM305, shown in [Figure 2.1](#), is an easy to use weight indicator. The ZM305 comes in a stainless steel housing with an IBC display for high contrast visibility in all conditions. The indicator has a USB port, two serial COM ports and an Ethernet port. Available options are Analog Output, Current Loop/RS485/RS422, USB Device, Wireless Ethernet 802.11g internal module cards, STVS (Severe Transient Voltage Suppression) protection and external battery pack.

The indicator also has three logic level inputs with configurable functions and three setpoint outputs. See the Specification literature for a full list of specifications.

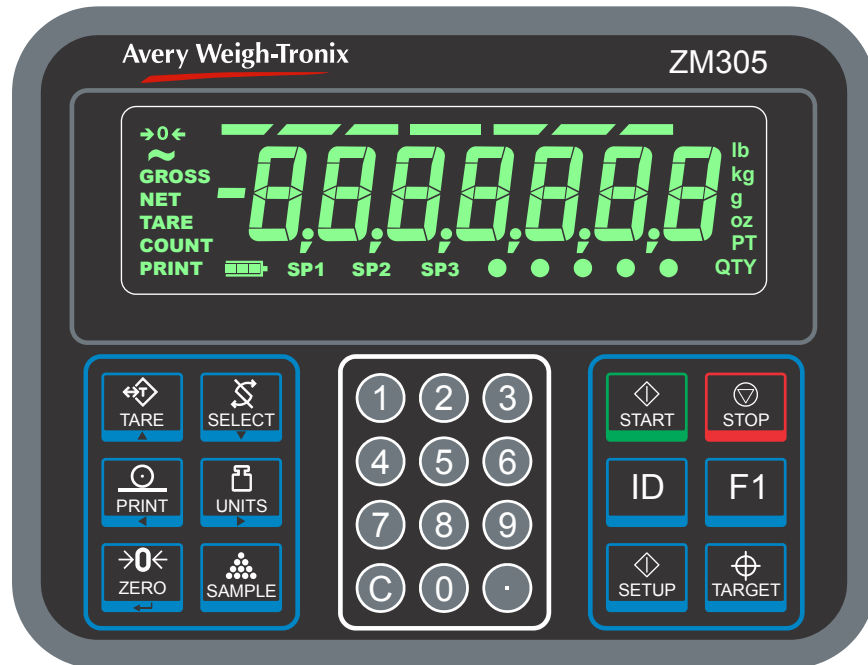

Figure 2.1 Front panel of the ZM305 indicator display

The ZM305 can connect to USB flash drives, printers, remote displays, computers and other peripheral devices via USB, ethernet and serial connections.

2.1 Front panel

The front panel, shown in [Figure 2.1](#), consists of the keys and display.



Never press a key with anything but your finger. Damage to the overlay may result if sharp or rough objects are used.

The normal function of the keys on the front panel are listed below. Some keys will have special functions in certain applications. Details are provided in the individual application sections.

	<p>Press the TARE key to perform a tare function. Also prompts for a keyboard tare, if enabled. Acts as an up arrow key for menu navigation. Allows you to access minus and comma signs.</p>
	<p>Press the SELECT key to toggle between the active display values. Press and hold to enter the setpoint editor. Acts as a down arrow key for menu navigation. Allows you to access minus and comma signs.</p>
	<p>Press the PRINT to send information to a peripheral device through a configured communications port. Performs accumulator function, if enabled. Acts as a left arrow key for menu navigation.</p>
	<p>Press the UNITS key to scroll through the available units of measure while in normal operating mode. Acts as a right arrow key for menu navigation.</p>
	<p>Press the ZERO key to zero the display. Acts as an ENTER key to accept a displayed value or function.</p>
	<p>Press the SAMPLE key to setup counting functions.</p>
	<p>Press the START key to start or resume a batching specific action.</p>
	<p>Press the STOP key to stop or pause a batching specific action.</p>
	<p>Press ID to show the current ID value. Press and hold ID to enter a new ID value.</p>
	<p>Press the F1 key to select application specific choices. Aborts a numeric entry and acts as an ESCAPE key in the menu navigation. Also used to display or enter an accumulator channel.</p>
	<p>Press the SETUP key to access the setpoint editor. Press and hold to view the password entry screen for menu access.</p>
	<p>Press the TARGET key setup checkweighing functions.</p>
	<p>Use the numeric keypad to enter numbers in the appropriate screens. Press the C (CLEAR) key to clear the last entry.</p>

2.1.1 Annunciators

The annunciators on the display are shown and labeled in [Figure 2.2](#).

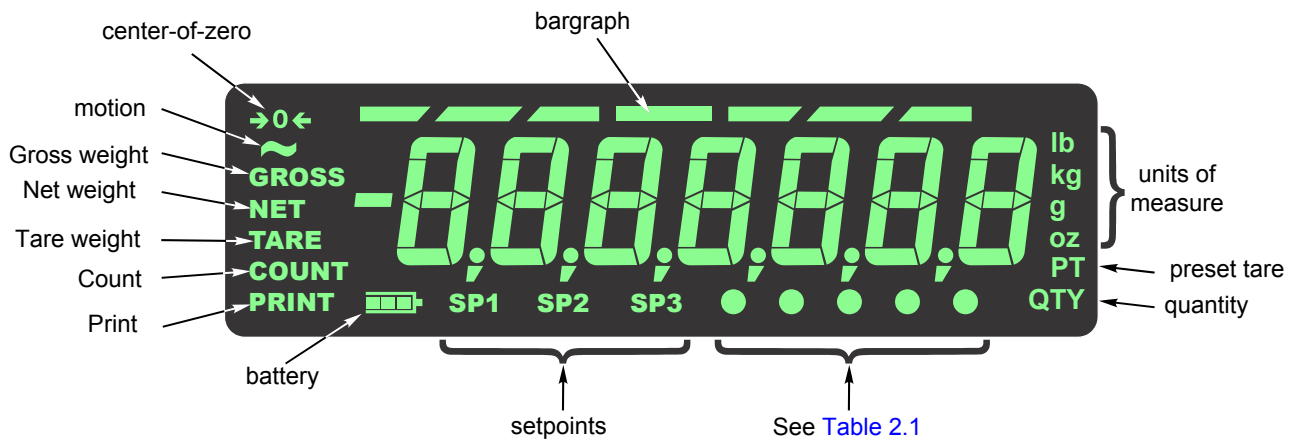

Figure 2.2 Annunciators

These annunciators will light during operation to inform the user of the weighing mode, active unit of measure, etc.

Table 2.1 Circle Annunciator assignments

Annunciator	Indicates
Circle 1 (left most)	Network activity
Circle 2	Custom unit
Circle 3	Pieceweight
Circle 3 & 4	Minimum
Circle 4 & 5	Maximum
Circle 3, 4, & 5 + GROSS or NET	In Motion

2.2 Powering up the ZM305

The indicator is always active as long as power is received. Power can be supplied by:

- AC power cord connected to a properly grounded outlet (100 VAC - 240 VAC, 50 or 60 Hz)
- ZM-BAT - Optional external non-charging battery pack with 4 D cells
- DC power source (12 to 36 VDC)

2.3 Entering a negative number

To enter a negative number, press the **C** key to clear the current value from the display. With only one digit displayed press **SELECT**. The first character will be the (-) negative sign. Enter the rest of the digits normally.

3 Indicator applications

This indicator has several weighing applications that can be enabled through a password protected menu. Only one application can be enabled at a time. The applications available are:

- **General Weighing** (explained on page 15)
- **Accumulator** (explained on page 21)
- **Parts Counting** (explained on page 23)
- **Checkweighing** (explained on page 26)
- **Batching** (explained on page 29)
- **Peak Hold** (explained on page 32)
- **Remote Display** (explained on page 33)
- **In-Motion** (explained on page 34)

The indicator comes with the default application called General Weighing active.

3.1 General weighing application

This section applies if the General Weighing application is active. Features described here also apply to the other applications except where noted in those application instructions.

3.1.1 **SELECT** key default function

In the General Weighing application you can view the gross, net and tare display values by repeatedly pressing **SELECT**.

3.1.2 **Gross weighing**



*To change unit of measure, press **UNITS**.*

To perform gross weighing, power up the unit and follow these steps:

1. Empty the scale and press **ZERO** to zero the display ...
0 is displayed and the *center-of-zero* annunciator lights.
2. Place item to be weighed on the scale ...
Weight is displayed.
3. Repeat steps 1 and 2.

3.1.3 Net weighing

Net weighing is available via three types of tare entry.

Pushbutton tare When enabled press **TARE** to tare the weight on the scale.

Entered tare When enabled key in a tare weight and press **TARE** to set.

Preset tare When enabled press **TARE** to recall a preset tare numbered 1-10.



Pushbutton and Entered Tares can be enabled simultaneously. If Preset Tare is enabled, Pushbutton and Entered Tares are automatically disabled.

There is an auto tare clear feature. If this is enabled, after a weighment, when the weight falls into the gross zero band, tare is cleared to zero.

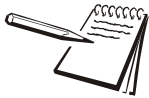

Definition: Gross zero band - this is a configured value that defines a window around gross zero. This is used in several ways in different applications.

The three types of tare are explained below.

Using Pushbutton Tare

To perform a net weighment using pushbutton tare, power up the unit and follow these steps:

1. Place item to be tared on the scale ...
Weight is displayed.
2. Press **TARE** ...
0 is displayed and the *NET* annunciator lights.
3. Place material to be weighed into or on the tared item on the scale ...
Net weight of material is displayed.
4. Repeatedly press **SELECT** to view the gross, tare, and net values.
5. If repeated weighments use the same tared item, you do not need to establish a new tare value as described in step 1 and 2.
6. To clear a tare value, press and hold the **TARE** key until ...
cLEARed is displayed.

Using Entered Tare

To perform a net weighment using entered tare, the following steps describe a typical operation:

1. With no weight on the scale, if the display does not read **0** press **ZERO** ...
0 is displayed and the *center-of-zero* annunciator lights.

2. Key in the tare value of the container or box that will be used to hold the material that requires a net weight value, and press **TARE** ...

Tare weight is displayed as a negative value and the *NET* annunciator lights.

3. Place the container or box and material to be weighed on the scale ...

Net weight of material is displayed.

4. If repeated weighments use the same tared item, you do not need to establish a new tare value as described in step 2.

5. To remove the tare weight from the scale, enter **0**, then press **TARE** ...

The tare is cleared and the scale is in gross weigh mode.

Using Preset Tare

Preset tares are available if entered in a password protected menu by a supervisor. There can be up to 10 tares numbered 1-10. To perform a net weighment using one of the preset tares, follow these steps:

1. With no weight on the scale, if the display does not read **0** press **ZERO** ...

0 is displayed and the *center-of-zero* annunciator lights.

2. Press **TARE** ...

Tare number entry screen appears.

3. Key in the preset tare number and press **ZERO** ...

Tare weight is displayed as a negative value and the *NET* annunciator lights.

4. Place container or box and material to be weighed on the scale ...

Net weight of material is displayed.

5. Repeat step 4 until you are finished using that tare weight.

6. To clear a tare value, press and hold the **TARE** key until ...

cLEARed is displayed.



Tare is removed automatically if Auto Tare Clear is enabled.



If the active unit of measure is lb-oz then tare weights must be entered in the oz equivalent. To enter 2 lb 4.5 oz you would need to enter 36.5 oz (2 lb = 32 oz plus the 4.5)

3.1.4 Using setpoints

Setpoints are values (weight) at which outputs are triggered automatically. Outputs can control relays connected to valves, lights, other machinery, etc. Setpoint outputs can be configured in the setpoint menu shown in [Figure 3.1](#).

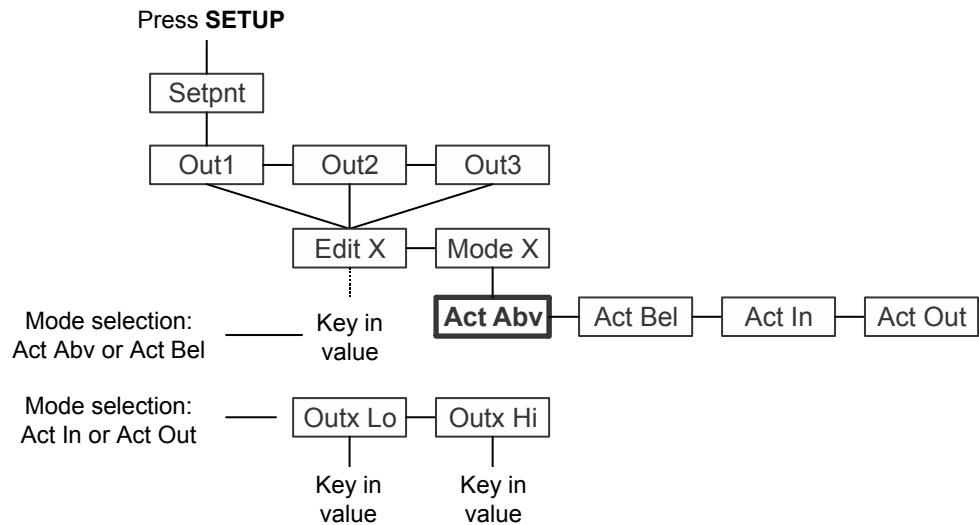

Figure 3.1 Setpoint menu



Default Setpoint operation

Mode = Active Above

Outputs must be enabled for setpoints to operate. See the Service Manual:

Below Configured Value:

Outputs are OFF

Annunciators are OFF

Above Configured Value:

Outputs are ON

Annunciators are ON

The setpoint outputs and setpoint annunciators logic state can be inverted from their default settings. Refer to details in the password protected menu settings in the section titled [Setpoint on page 51](#).

Follow these steps to configure the outputs:

1. Press **SETUP** ...

out1 is displayed. This is the weight value for setpoint 1. You can access **out2** or **out3** by pressing the **UNITS** key. The following instructions apply to any of these three outputs.

2. Press **SELECT** ...

Edit X is displayed. **X** being the number of output.

3. Press **UNITS** ...

Mode X is displayed. This menu item sets the function of the output. Mode selection must be made before entering the Out value.

4. Press **SELECT** ...

The current Mode setting for the selected Output is displayed. The Mode settings are listed below:

Act AbV (default)	The output is active when the weight is above the set value
Act bEL	The output is active when the weight is below the set value
Act in	The output is active when the weight is inside of the low and high set values
Act out	The output is active when the weight is outside of the low and high set values

5. Press **UNITS** or **PRINT** to scroll through the choices shown above and then press **ZERO** to accept the displayed Mode ...

ModE X is displayed.

6. Press **UNITS** ...

Edit X is displayed. Set the value or values for the output under this menu item.

7. Press **SELECT** ...

If you selected Mode **Act AbV** or **Act bEL**, a value entry screen is displayed. Go to step 8.

If you selected Mode **Act in** or **Act out**, **outX Lo** is displayed. This is one of two value entry screens under **Edit X**. Go to step 9.

8. Key in a value the you want the output to activate above or below and press **ZERO** to accept the value.

Edit X is displayed. Go to step 13.

9. Key in a value for **outX Lo** and press **ZERO** to accept ...

outX Lo is displayed.

10. Press **UNITS** ...

outX Hi is displayed.

11. Key in a value for **outX Hi** and press **ZERO** to accept ...

outX Hi is displayed.

12. Press the **TARE** key ...

Edit X is displayed.

13. Press the **TARE** key ...

OutX is displayed.

14. Repeat steps 1 through 12 for **out2** and **out3**.15. Press **TARE** repeatedly to return to normal weighing mode with the setpoints active.

3.1.5 Printing

To print the current weight information, press **PRINT**. The configured print format will be transmitted through the configured port to the connected peripheral device. The indicator can be configured to only allow one print for each weighing sequence. If **PRINT** is pressed more than once when so configured, then **cAnt** will appear instead of printing again.

Refer to [Default print formats on page 46](#).

Printing any of the configured print formats is possible using the Numbered Print feature. Enter the print format number and then press the **PRINT** key. The selected print format will be transmitted out all ports that are configured to print.

3.1.6 ID Entry

A numeric ID can be entered for use with transmitted or printed transactions. Press and hold the **ID** key and the message *id* is displayed followed by the current ID value. Enter up to seven digits (numeric only) and press **ZERO**. To review press the ID key and the active ID will be displayed for a few seconds before returning to normal operation.

3.2 Accumulator application

This section applies if the Accumulator application is active.

3.2.1 **SELECT** key default function

In the Accumulator application you can view the Gross, Net, Tare, Gross Total, Net Total and Transaction Count display values by repeatedly pressing **SELECT**.

When the Gross Total is displayed, both the *GROSS* and *QTY* annunciators will be lit. When the Net Total is displayed, both the *NET* and *QTY* annunciators will be lit. When the Transaction Count is displayed, the *QTY* annunciator is lit.

3.2.2 **Special key functions**

The following key has an extra function in this application:

F1 Press **F1** and the active accumulator channel (*chAn X*) appears. Enter a value from 1 to 200 to select the active accumulator.

3.2.3 **Accumulator operation**

The accumulator application can be used to record totals of individual weighments.

Follow these steps:

1. Press **ZERO** to zero the scale, if necessary ...
0 is displayed.
2. Place item on the scale ...
Weight is displayed.



You can use gross or net weighing with the accumulator application as it stores both gross and net totals. You have 200 accumulator channels that can be used to store totals.

F1 accesses the different channels for accumulating data. Pushbutton tare is available for the current channel.

Each accumulator channel has it's own individual gross, tare and net totals, transaction counter and an ID, if entered.

3. Press **PRINT** to add weight to the accumulator and to print the selected print format ...
The *PRINT* annunciator lights and **Acc** is briefly displayed.
4. Remove weight from the scale. Weight must return to inside the gross zero band before another print and accumulation can be recorded.
5. Repeat steps 2 through 4 for each weighment you want to accumulate.

Indicator applications

If enabled, press and hold **PRINT** for three seconds to print and/or clear the active accumulator values. These functions are enabled or disabled in the password protected menu.

The indicator can be configured to not allow printing or accumulating when the weight is inside the Gross Zero Band.

3.3 Counting application

This section applies if Counting is active.

3.3.1 **SELECT** key default function

In the Counting application you can view the gross, net, tare, count total, transaction total, count and piece weight display values by repeatedly pressing **SELECT**.

3.3.2 **Special key functions**

The following keys have an extra function in this application:

SAMPLE Press **SAMPLE** to perform the sample operation as described below in the Dribble and Bulk sections.

Press and hold **SAMPLE** to perform the piece weight entry as described below.

F1 **F1** works the same as the **SAMPLE** key when pressed.

3.3.3 **Sample operation**

There are two types of sampling to select from; bulk and dribble. Either type is selectable under a password protected menu. The default sample size for each is five but is selectable from 1-100,000.

Dribble sampling In this sampling method you can count out the specified number of items onto the scale and when you are ready, press the **SAMPLE** or **F1** key and the scale starts to calculate piece weight and then shows the count.

Bulk sampling In this sampling method you place the specified number of items on the scale all at once (in bulk) and the scale automatically starts to calculate piece weight and then shows the count. This is the default sampling method.

Each method is described below.

3.3.4 **Dribble sampling**

With the dribble sampling method active, follow these steps to count.

1. Press **ZERO** to zero the scale, if necessary.
2. Use a tare method to tare a container, if necessary. See [Net weighing on page 16](#).
3. Press **SAMPLE** or **F1** ...

ZEroring is briefly displayed. This means the indicator is zeroing itself. A numeric value (**XX**) is then displayed. This is the current sample size.

4a. Accept the current sample size by pressing **ZERO**

OR

4b. Enter a new sample size and press **ZERO** ...

Add is displayed. Count the number of sample items onto the scale and when ready press **SAMPLE** or **F1** ...

buSY is briefly displayed, followed by one of two possible outcomes:

- a. If the sample met the minimum sample requirements and the weight is stable, the display will show the correct number of parts on the scale and **COUNT** is lit.
- b. If the sample size was not large enough or if the weight was unstable, **Abort** is briefly displayed and the display returns to gross weighing mode. Repeat steps 3 through 5 using a larger sample size.



Minimum sample weight is the gross zero band value. The initial sample count is 5 pieces. The maximum number of pieces that can be sampled is 100,000.

5. Place the parts on the scale to be counted. To accumulate the count and number of transactions, press **PRINT** while in count mode.

6. If enabled, press and hold **PRINT** for three seconds to print and/or clear the active count total. These functions are enabled or disabled in a password protected menu.

3.3.5 Bulk sampling

With the counting application and the bulk sampling method active, follow these steps to count.

1. Press **ZERO** to zero the scale, if necessary.

2. Use a tare method to tare a container, if necessary. See [Net weighing on page 16](#).

3. Press **SAMPLE** or **F1** ...

Zeroing is briefly displayed. This shows the indicator is zeroing itself. A numeric value (**XX**) is then displayed. This is the current sample size.

4a. Accept the current sample size by pressing **ZERO**

OR

4b. Enter a new sample size and press **ZERO** ...

Add is then displayed.

5. Place the correct number of samples on the scale all at the same time.

buSY is briefly displayed, followed by one of two possible outcomes:

- a. If the sample met the minimum sample requirements and the weight is stable, the display will show the correct number of parts on the scale and **COUNT** is lit.

- b If the sample size was not large enough or if the weight was unstable, **Abort** is displayed and the display returns to gross weighing mode. Repeat steps 3 through 5 using a larger sample size.



Minimum sample weight is the gross zero band value. The initial sample count is 5 pieces. The maximum number of pieces that can be sampled is 100,000.

6. Place the parts on the scale to be counted. To accumulate the count and number of transactions, press **PRINT** while in count mode.
7. If enabled, press and hold **PRINT** for three seconds to print and/or clear the active count total. These functions are enabled or disabled in a password protected menu.

3.3.6 Piece weight entry

Piece weight can be entered manually.

1. Press and hold **SAMPLE**.
The current piece weight is displayed.
2. Key in a new value and press **ZERO** to accept.

3.4 Checkweighing application

This section applies if your indicator has the Checkweighing application enabled.

3.4.1 SELECT key default function

In the Checkweighing application you can view the gross, net and tare display values by repeatedly pressing **SELECT**.

3.4.2 Special key functions

The following keys have an extra function in this application:

TARGET Press **TARGET** to set the target weight or upper and lower limits, as described below.

F1 **F1** works the same as the **TARGET** key when pressed.

3.4.3 Checkweigh operation

Checkweighing allows a quick, visual check of the acceptability or unacceptability of an item's weight. Figure 3.2 shows the checkweighing bargraph at the top of the display.

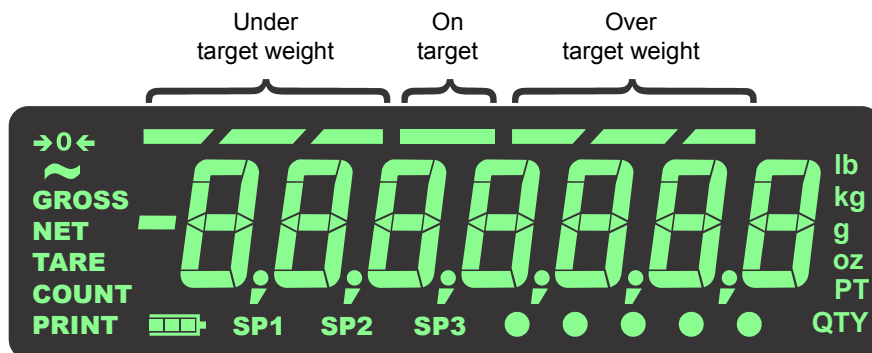

Figure 3.2 Checkweighing bargraph

There are two ways to set a target weight:

- **Weigh the target object** - If you use this method the acceptable weight will be the actual weight of the target sample \pm a predefined range (default is ± 1 division).
- **Key in upper and lower weight limits** - If you use this method the acceptable weight is any weight which falls between the upper and lower limits.

Each of these is explained below.



The checkweighing annunciators are based off of net weight so if a tare is active only the net weight is considered for checkweighing. If there is no tare, gross weight is used as the basis for the annunciators.

3.4.4 Weighing a target object

With the indicator in checkweighing mode, follow these steps to set a target by weighing an object.

1. Press **ZERO** to zero the scale, if necessary.
2. Enter a tare if necessary. Refer to [Net weighing on page 16](#) for instructions.
3. Place an object of the desired weight on the scale and press **TARGET ...**

The weight is displayed and the middle bargraph segment lights as well as the *SP2* annunciator.



*The acceptable target window is a range from **Target Object weight ± a predefined range** entered in a password protected menu.*

*The farther the weight is from the target weight, more over or under bargraph segments will light. The **UNDER** and **OVER** bargraph segments are fixed at 1 division each.*

4. Remove the object and replace with the next object to be checked.

The bargraph will show if the weight is under, over or within the target weight range. If the weight is under, *SP1* annunciator and the **UNDER** bar segments will light. If the weight is over, *SP3* annunciator and the **OVER** bar segments will light.

5. Repeat step 4 until you are finished weighing items.

The current target weight will be active until you repeat steps 1 through 3 with a new item of a different weight.

3.4.5 Setting upper and lower limits

With the indicator in checkweighing mode, follow these steps to set a target by setting upper and lower limits.

1. Press **ZERO** to zero the scale, if necessary.
2. Enter a tare if necessary. Refer to [Net weighing on page 16](#) for instructions.
3. With weight inside the gross zero band, press **TARGET ...**

Lo will be displayed briefly and then the current value for the lower accept weight.

4. Press **ZERO** to accept this or key in a new lower accept weight and press **ZERO ...**

Hi is briefly displayed and then the current value for the upper accept weight.

5. Press **ZERO** to accept this or key in a new upper accept weight and press **ZERO ...**

The display returns to normal weighing mode.

6. Place a weight on the scale ...

If the weight is below the lower accept weight, the left bargraph segments will light.

Any weight between the lower and upper acceptable weights will cause the middle bargraph segment to light to show the weight is within the target range.

If the weight is above the upper acceptable weight, the right bargraph segments will light.

7. Remove the item from the scale and repeat step 6 to check other items.
8. To set new upper and lower limits, repeat steps 1 through 5.

3.4.6 Setpoint operation in the checkweighing application

Inside the Gross Zero Band = All outputs and annunciators are off.

Under Target or Below Low Accept Weight = SP1 annunciator and Output 1 are on.

Inside Target = SP2 annunciator and Output 2 are on.

Over Target or Above Upper Accept Weight = SP3 annunciator and Output 3 are on.



Outputs have to be enabled (see Service manual).

Contact AWTX technical support for information about setpoint use with battery operated scales.

Outputs can be set as latched or unlatched in a password protected menu.

If outputs are unlatched

The annunciators and outputs follow the status of the bargraph except in gross zero band.

If outputs are latched

The annunciators' and outputs' status is determined by where the first stable weight occurs after an item is placed on the scale. The latched annunciator and output is reset OFF only when weight returns inside the gross zero band.

3.5 Batching application

This section applies if your indicator has the Batching application active.

3.5.1 SELECT key default function

In the Batching application you can view the gross, net and tare display values by repeatedly pressing **SELECT**.

3.5.2 Special key functions

The following keys have an extra function in this application:

- START** Press **START** to start or resume a batch operation.
- STOP** Press **STOP** to pause a batch operation.
Press **STOP** a second time in succession to abort the batch operation.
- F1** **F1** acts as a **START** and a **STOP** key on successive presses.



The Batch application has added selections for Preact values (1-3) in the Setpoint menu, shown below:

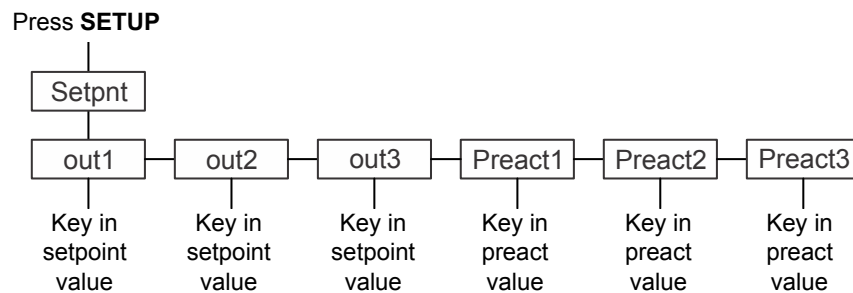

Setpoint or Preact values can be either positive or negative, up to or equal to scale capacity. See [Entering a negative number on page 14](#) on how to enter negative values.



PREACT definition - A preact is the amount of material in free fall.
For example: You would like 1000 lbs of material added to a scale but when the supply valve closes you always end up with a final weight that is 120 lbs over the desired amount.

To correct this, set a preact of 120 lbs. This causes the setpoint controlling the material to stop sooner and allows the material in free fall to be accounted for in the final weight.

In Discharge or Negative fill applications using manual preact, the preact weight will typically be entered as a negative value.

3.5.3 Batching operation

Batching allows the indicator to control up to three motors, timers, augers, gates, etc. using the three outputs for the purpose of making batches based on weight.

There are four types of batching operation:

- 2-speed single ingredient
- Ingredient filling (up to three ingredients)
- Independent setpoints filling
- Fill/discharge operation

Other parameters, that are set in a password protected menu, affect the batching operation.



The bargraph will sequentially light up to show from 0 to 100% of the batch weight in all types of batching except the independent setpoints.

3.5.4 2-Speed filling

2-Speed is for a single ingredient with a dual speed filling control (Fast/Slow), typically a valve or hopper gate that can be full open, partially open or closed. When the fill starts both *SP1* and *SP2* are turned on (outputs activated) which should set the dual speed control to full open (Fast speed). When the Out 1 value is reached *SP1* and Output 1 are turned off and this should set the dual speed control to partial open condition (Slow speed). When Out 2 value is reached *SP2* and Output 2 are turned off to close the control device and complete the fill. *SP3* and Output 3 can be used as a Batch Cycle Active indicator.

1. Press **SETUP** or press and hold **SELECT** to access the setpoint editor.
2. Set Out1 to the fast fill value and Out 2 to the slow fill value.



Example: To fill a product to 100 lb with the last 5 lb on slow fill: Out 1 should be set to 95 and Out 2 should be set to 100.

3. To start or restart the 2-speed filling process, press **START** or **F1**.
4. To stop the filling process, press **STOP** or **F1**. (**F1** toggles the process on and off.)

3.5.5 Ingredient filling

Ingredient filling is for batching up to 3 different ingredients controlled by Out 1, 2 and 3 values. If Out 2 value is 0 then it operates as a single ingredient filler. If Out 3 value is 0 then it operates as 2 ingredient batcher.

1. Press **SETUP** or press and hold **SELECT** to access the setpoint editor.
2. Set Out1 to the ingredient 1 value, Out 2 to the ingredient 2 value and Out 3 to the ingredient 3 value. See more details on Gross or Net weight batching in [Notes on batching on page 75](#).

3. To start or restart the batching process, press **START** or **F1**.
4. To stop the batching process, press **STOP** or **F1**. (**F1** toggles the process on and off.)

3.5.6 Independent setpoints

Independent Setpoint works like the general weighing mode setpoints with the addition of start/stop controls. You can also do negative weight/discharge using this mode.

1. Press **SETUP** or press and hold **SELECT** to access the setpoint editor.
2. Set Out1, Out 2 and Out 3 values.
3. To start or restart the setpoints, press **START** or **F1**.
4. To stop the process, press **STOP** or **F1**. (**F1** toggles the process on and off.)

3.5.7 Fill/Discharge

Fill/Discharge mode is typically used for applications that use negative filling to dispense a smaller amount of product from a large vessel, tank or hopper type scale. The vessel (tank or hopper) is filled to a set gross weight and then multiple operations of filling via negative amount of weight into bags or containers can be completed before the vessel (tank or hopper) requires a recharge or refill.

Fill Out 1 is assigned as the gross fill amount for the vessel (tank or hopper) and **START** or **F1** key starts the fill. The fill is based only on gross weight. If you have Out 1 set to 2000 and the scale already has 500 lb remaining, the Output 1 will cutoff (and annunciator *SP1* turns off) when the additional 1500 is added for a total gross of 2000 lb.

Discharge Out 2 is assigned as the discharge fill amount (negative weight) with the **TARE** key used to initiate the discharge cycle. The scale will tare prior to activating Output 2 (*SP2* annunciator will light). An operator can perform multiple discharge operations. When the vessel gross weight is low, perform a refill.

1. Press **SETUP** or press and hold **SELECT** to access the setpoint editor.
2. Set Out1 to the gross fill weight in the vessel or container. Set Out 2 to the weight of the product to be discharged into smaller bags or containers.
3. To start or restart the large vessel fill process, press **START** or **F1**.
4. To stop the large vessel filling process, press **STOP** or **F1**.
5. Press **TARE** to start the bag filling process.
6. To stop bag filling process, press **STOP** or **TARE**.

3.6 Peak hold application

This section applies if your indicator has the Peak Hold application active.

3.6.1 **SELECT** key default function

In the Peak Hold application you can view the gross, max and min display values by repeatedly pressing **SELECT**.

3.6.2 **Special key functions**

The following key has an extra function in this application:

F1 **F1** resets the min and max peak weights to the current gross weight.

3.6.3 **Peak hold operation**

Only the highest weight applied to the scale is displayed when the peak weight value is selected to be displayed. Minimum weight is designated by a pair of green *circle* annunciators. Maximum weight is designated by a different pair of green *circle* annunciators. See [Figure 3.3](#).

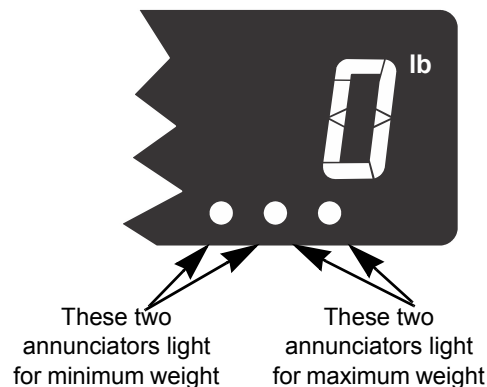

Figure 3.3 Min/Max annunciators

With the Peak application active, follow these steps to perform and view peak weighments.

1. Repeatedly press **SELECT** until the two green circle annunciators on the right light up. See [Figure 3.3](#). This means you are now viewing the peak or maximum weight.
2. With no weight on the scale, press **ZERO**, if necessary press **F1** to reset any previous peak value on the display.
3. Place weight on the scale and then remove it ...

The display will show the peak weight recorded during the weighment.

4. To reset the peak, press **F1** ...

The minimum and maximums are reset to the **current gross weight**.

5. Repeat the steps to perform another peak weighment.

Below is an example of the minimum weight display. Note the pair of circle annunciators that are lit.



Below is an example of the maximum weight display. Note that a different pair of circle annunciators are now lit.



3.7 Remote display application

This section applies if you have the Remote Display application active.

The indicator can be configured to work as a remote display with other compatible indicators or the GSE 350 IS and 355 IS.

To use a ZM indicator to operate as a Remote display for a Primary indicator you must configure settings in the Supervisor menu and in a separate password protected menu.

A remote indicator will display the same information as the primary indicator and pressing the main function keys (Tare, Select, Zero, Print, and Units) on the remote will function as if they were pressed on the primary indicator.



Numeric entries are non-functional from a remote display unit, or secondary indicator, such as numeric tare entry, numeric ID entry, etc.

If the Remote indicator is connected to a GSE 35xIS Primary indicator, then additional features and options may be available for use from the remote such as setpoints, remote inputs, Com port communication forwarding to local devices and analog output option.

Contact your local Avery Weigh-Tronix representative for information on setting up the ZM indicator as a Remote or Primary indicator.

3.8 In-Motion application

This section applies if you have the In-Motion application active.

In-motion weighing involves items moving across a conveyor scale. When the item is completely past the beam of the entrance photo-eye the weight capture starts at the ADC rate of 80 samples per second. While weight is being captured the indicator will show `-----`. When the item breaks the beam of the exit photo-eye the weight capture stops and the average of all the weight readings is displayed for a configured length of time or until the next item breaks the beam of the entrance photo-eye.



A print of the averaged weight value will occur when the exit photo eye is tripped.

If the averaged weight timer expires before the next item arrives the display will show middle dashes.

3.8.1 SELECT key operation

Press the **SELECT** key to toggle between gross weight and the in-motion weight. The in-motion weight will have either the *Net* or *Gross* annunciator turned on depending on if Tare is active.

4 Menus

Password protected menus are available to configure the indicator and/or view information.

4.1 Accessing the menus

Follow these steps to access the menus in the ZM305.

1. With the indicator powered up and in normal operating mode, press and hold **F1** ...

Pass is displayed, prompting you to enter the password.

2. Key in the password for the menu you want and press the **ZERO** key ...

The first item in the top level of the menu you accessed is displayed.

3. Use the navigation keys, shown below, to navigate through the menu structure. The symbols in the chart appear on the bottom of the keys.

Press **SELECT**/ ▼ to move down in a menu
 Press **TARE**/ ▲ to move up in a menu, except at the bottom item in a menu, then use **ZERO**/ ← or **F1**
 Press **PRINT**/ ◀ to move left in a menu
 Press **UNITS**/ ▶ to move right in a menu
 Press **ZERO**/ ← to accept a value or choice and move up in the menu.
 Press **F1** to escape and move up in the menu

4.2 Menu annunciators

The menu structure is made up of menu items, parameters, value entry screens and lists from which you choose one item. To help you know where you are in the menu, the bargraph at the top of the display is on while the indicator is in the menus and will change appearance according to the following rules:

All segments flashing	This means you are in the menu structure but not in any of the following screens.
Center flashing / others solid	This means you are in a parameter prompt screen.
Center flashing / others off	This means you are in a numeric entry screen. Enter a number and press ZERO to accept.
Right flashing / others off	This means you are in a list. Scroll through the choices with the PRINT and UNITS keys and press ZERO to accept.

4.3 Exiting the menus

1. If you are at the bottom item in a menu use **ZERO** to accept a choice or value and move up a level, or use **F1** to escape and move up one level without accepting the choice or value. From that point, press **TARE** repeatedly until ...

SAVE no is displayed. This means “Do not save changes.”

2. Press **UNITS** to scroll through the choices: **SAVE no**, **SAVEYES** and **CAnCEL**. Press **ZERO** to accept the displayed choice.

If you choose **SAVE no** or **SAVEYES** the indicator exits the menu and returns to normal weighing mode.

OR

If you choose **CAnCEL**, the indicator remains in the menu.

4.4 USER level menus

The USER level menus are available to the user. The other menu levels are for supervisors and technicians only.

The USER level (password 111) contains the User, About, and Audit menus arranged as shown in [Figure 4.1](#).

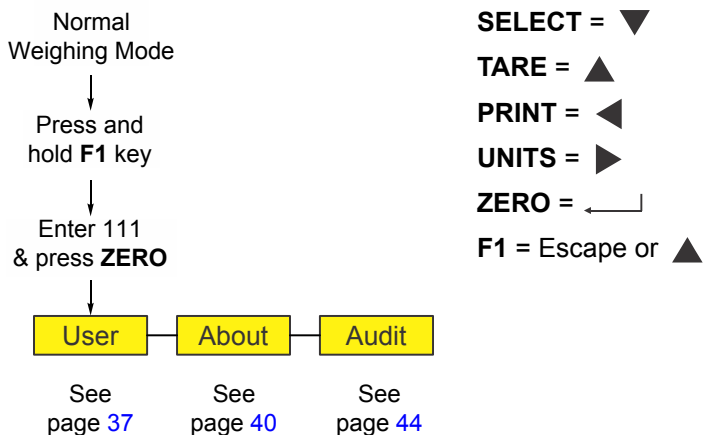

Figure 4.1 USER level (password 111) menus

4.5 User menu

The User menu is shown in Figure 4.2.

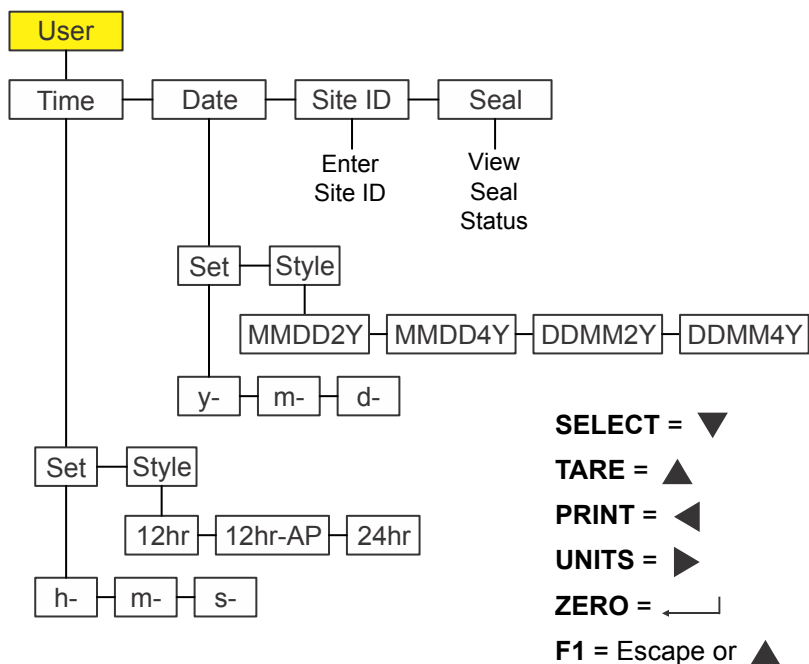

Figure 4.2 User menu

Use this menu to set the time and date, to enter a site ID, and view the physical seal status. Each is explained below:

4.5.1 Time

User ↓ Time



The ↓ and → symbols used in this section stand for direction moved in the menu. So User ↓ Time, shown above, illustrates that you move down from **uSER** to **tiME**. This will help you keep track of where you are in the menu structure.

1. Access the User menu (see *Accessing the menus on page 35*) and press **SELECT** ...
tiME is displayed. Use this to set the time and clock style.
2. Press **SELECT** ...
SEt is displayed.
3. Press **SELECT** ...
h- x is displayed, with the **x** flashing. This is a numeric entry screen for the hour value.

4. Key in the hour of the day using military (24 hr) time and press **ZERO** to accept ...
M- x is displayed, with the **x** flashing. This is a numeric entry screen for the minute value.
5. Key in the minute value and press **ZERO** to accept ...
S- x is displayed, with the **x** flashing. This is a numeric entry screen for the second value.
6. Key in the seconds value and press **ZERO** to accept ...
SEt is displayed.
7. Press **UNITS** ...
StYLE is displayed. Use this to set the style of clock for printouts. Choices are **12hr**, **12hr-AP** (AM/PM) and **24hr** (military time).
8. Press **SELECT** ...
12hr is displayed.
9. Press **UNITS** to scroll through the choices. Press **ZERO** to accept the displayed choice ...
StYLE is displayed.
10. Press **TARE** ...
tiME is displayed.

4.5.2 Date

User ↓ Time → Date

1. From **tiME**, press **UNITS** ...
dAtE is displayed.
2. Press **SELECT** ...
SEt is displayed.
3. Press **SELECT** ...
y- x is displayed, with the **x** flashing. This is a numeric entry screen for the year value.
4. Key in the year and press **ZERO** to accept ...
M- x is displayed, with the **x** flashing. This is a numeric entry screen for the month.
5. Key in the month value and press **ZERO** to accept ...
d- x is displayed, with the **x** flashing. This is a numeric entry screen for the day value.
6. Key in the day value and press **ZERO** to accept ...
SEt is displayed.

7. Press **UNITS** ...
StYLE is displayed. Use this to set the style of date for printouts.
 Choices are **MMDD2Y**, **MMDD4Y**, **DDMM2Y** and **DDMM4Y**.
8. Press **SELECT** ...
MMDD2Y is displayed.
9. Press **UNITS** to scroll through the choices. Press **ZERO** when your choice is displayed ...
 The choice is made and **StYLE** is displayed.
10. Press **TARE** ...
dAtE is displayed.

4.5.3 Site ID

User ↓ Time → Date → Site ID

1. From **dAtE**, press **UNITS** ...
Site id is displayed.
2. Press **SELECT** ...
 A numeric entry screen is displayed.
3. Key in a site ID number on the numeric keypad and press **ZERO** to accept ...
Site id is displayed.



The Site ID is used to identify the information being transmitted or printed is provided from this specific device. ASCII characters 32-126 can be used.

4.5.4 Seal

User ↓ Time → Date → Site ID → Seal

1. From **Site id**, press **UNITS** ...
SEAL is displayed.
2. Press **SELECT** ...
unSEALE or **SEALEd** is displayed. This is the status of the physical seal inside the indicator. If the unit is sealed, no changes can be made to the configuration of the indicator.
3. Press **F1** to return to the **SEAL** display.
4. To exit the menu, see *Exiting the menus on page 36*.

4.6 About menu

The About menu is shown in [Figure 4.3](#).

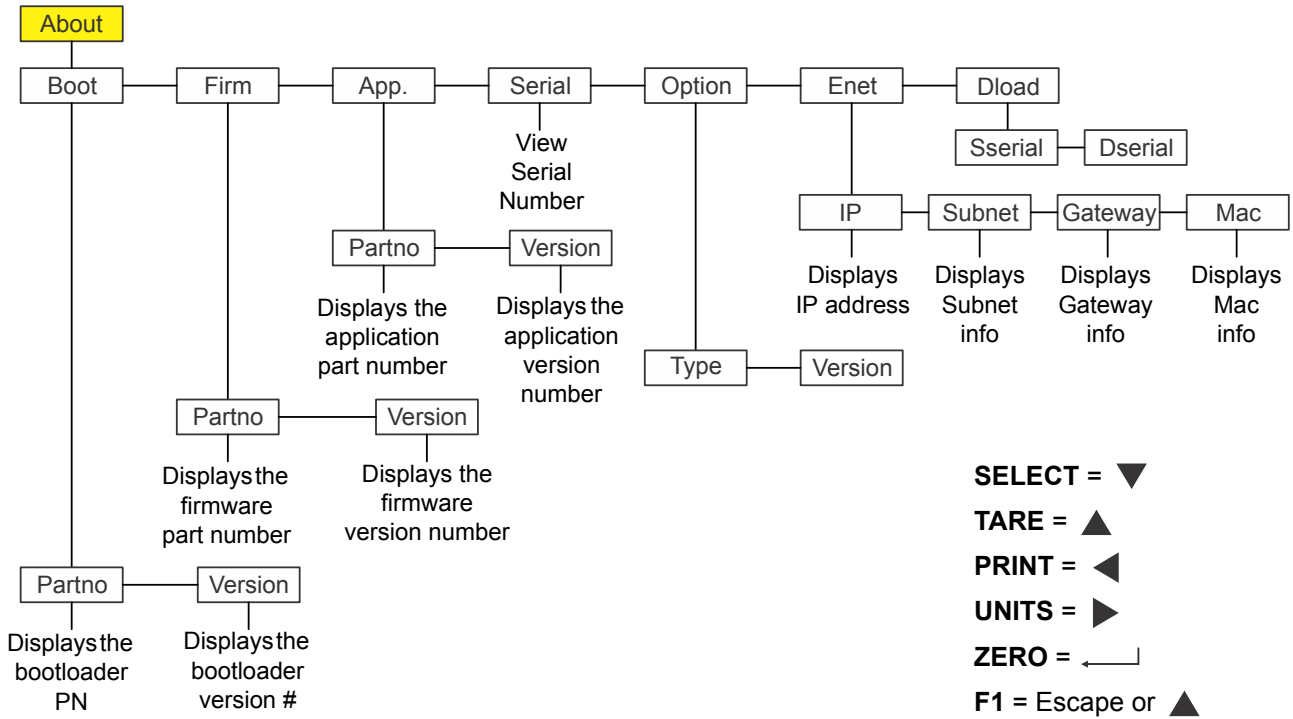

Figure 4.3 About menu

Use this menu to display information about the various items shown in [Figure 4.3](#). Each is explained below:

4.6.1 Boot

About ↓ Boot

1. Access the About menu and press **SELECT** ...
boot is displayed.
2. Press **SELECT** ...
PArtno is displayed
3. Press **SELECT** ...
The 1st half of the bootloader PN is displayed. Press **UNITS** to view the 2nd half.
4. Press **ZERO** to return to the **PArtno** display.
5. Press **UNITS** ...
VErSion is displayed.
6. Press **SELECT** ...
The version number of the bootloader is displayed.

7. Press **ZERO** to return to the **VERsion** display.
8. Press **TARE** to return to the **boot** display.

4.6.2 Firm and App

About ↓ Boot → Firm and App

1. From **boot**, press **UNITS ...**
FirM is displayed. This stands for firmware.
2. Repeat the same pattern of key presses in steps 2 through 7 to view the part number and version for the **FirM**. and **APP** menu items.

4.6.3 Serial

About ↓ Boot → Firm → App → Serial

1. With **APP** displayed, press **UNITS ...**
SEriAL is displayed.
2. Press **SELECT ...**
The first four digits of the indicator serial number are displayed. Press **UNITS** to view the last five digits.
3. Press **TARE** to return to the **SEriAL** display.

4.6.4 Option

About ↓ Boot → Firm → App → Serial → Option

1. From **SEriAL**, press **UNITS ...**
oPtion is displayed.
2. Press **SELECT ...**
VERsion is displayed. This stands for the software version of the currently installed option card. This can be useful service information.
3. To view the version, press **SELECT ...**
The software version number is shown.
4. Press **ZERO ...**
oPtion is displayed.
5. Press **UNITS ...**
tYPE is displayed. This stands for the type of option card installed. The four option cards are: Analog, 802.11g wireless, USB-d, and Current Loop/RS485/RS422.
6. Press **SELECT ...**
The currently installed option card name is displayed.

7. Press **ZERO** ...
tYPE is displayed.
8. Press **TARE** ...
oPtion is displayed.

4.6.5 Enet

About ↓ Boot → Firm → App → Serial → Option → Enet



If the indicator is connected to an ethernet network, the values displayed will be the current assigned addresses.

1. From **oPtion**, press **UNITS** ...
EnEt is displayed. Use this item to view the values for the IP, Subnet, Gateway and MAC addresses.
2. Press **SELECT** ...
iP is displayed. Use this item to view the four part IP address.
3. Press **SELECT** ...
1 XXX is displayed. This is first octet of the IP address
4. Press **ZERO** ...
2 XXX is displayed. This is second octet of the IP address.
5. Press **ZERO** ...
3 XXX is displayed. This is third octet of the IP address.
6. Press **ZERO** ...
4 XXX is displayed. This is fourth octet of the IP address.
7. Press **ZERO** ...
iP is displayed.
8. Press **UNITS** ...
Subnet is displayed.
9. Repeat this sequence of key presses for the **Subnet**, **Gateway** and **MAC** addresses.
10. When finished press **TARE** ...
EnEt is displayed.

4.6.6 Dload

About ↓ Boot → Firm → App → Serial → Option → Enet → Dload

1. From **EnEt**, press **UNITS ...**

dLoAd is displayed. This stands for download. Under **SSEriAL** you can view the serial number of the software application that created the configuration file. Under **dSSEriAL** you can view the serial number of the software application that downloaded the configuration file. This is used for security and licensing purposes.
2. Press **SELECT ...**

SSEriAL is displayed.
3. Press **SELECT ...**

The 1st half of the serial number of the creating application of the configuration file is displayed.
4. Press **ZERO** to show the 2nd half.
5. Press **F1 ...**

SSEriAL is displayed.
6. Press **UNITS ...**

dSSEriAL is displayed.
7. Press **SELECT ...**

The 1st half of the serial number of the downloading application of the configuration file was downloaded to, is displayed.
8. Press **ZERO** to show the 2nd half.
9. Press **F1 ...**

dSSEriAL is displayed.
10. Press **TARE** until **About** is displayed.
11. To exit the menu, see *Exiting the menus on page 36*.

4.7 Audit menu

The Audit menu is shown in [Figure 4.4](#).

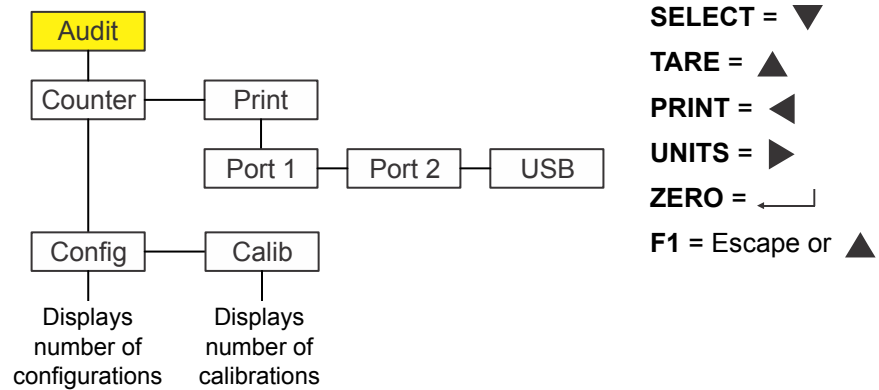

Figure 4.4 Audit menu

Use this menu to display audit counters for configuration and calibration and to print this information. Each is explained below:

4.7.1 Counter

Audit ↓ Counter

1. Access the Audit menu and press **SELECT** ...
countEr is displayed. This has two counters that tell you how many times the indicator has been configured and calibrated.
2. Press **SELECT** ...
conFig is displayed.
3. Press **SELECT** again ...
 A number appears showing how many times the indicator has been configured.
4. Press **ZERO** ...
conFig is displayed.
5. Press **UNITS** ...
cALib is displayed.
6. Press **SELECT** ...
 A number appears showing how many times the indicator has been calibrated.
7. Press **ZERO** ...
cALib is displayed.
8. Press **TARE** ...
countEr is displayed.

4.7.2 Print

Audit ↓ Counter → Print

1. From **countEr**, press **UNITS** ...
Print is displayed.
2. Press **SELECT** ...
Port1 is displayed. This is the first of three choices: **Port 1**, **Port 2** or **uSb**. Use these to select which port to print the audit report through.
3. Press **UNITS** to scroll through the choices and press **ZERO** when your choice is displayed ...
The audit log is printed through the chosen port and **Print** is displayed.
4. This completes the Audit menu. To exit the menu, see *Exiting the menus on page 36*.

5 Communications

The ZM305 can communicate through these ports:

- Serial
- Ethernet
- USB
- Wireless 802.11g

5.1 Default print formats

Below are examples of the default formats that are available:

General App. Default (Format #1)

```

Gross      3000 lb
Tare       1000 lb
Net        2000 lb
    
```

Accumulate App. Default (Format #2)
(See Format #8 for Totals)

```

Acc #       1
Trans #     3
Gross      3000 lb
Tare       1000 lb
Net        2000 lb
    
```

Count App. Default (Format #3)

```

Count      150
    
```

Checkweigh App. Default (Format #4)

```

Net        2000 lb
    
```

Batch App. Default (Format #5)

```

G          2000 lb
    
```

Peak App. Default (Format #6)

```

Peak       6000 lb
    
```

Remote Display Output (Format #7)

```

1000 lb G
    
```

Acc. Totals App. Def. (Format #8)
(See Format #2 for printout)

```
Acc #      1
Trans #    3
Gross Total 9000 lb
Tare Total  2000 lb
Net Total   7000 lb
```











In-Motion (Format #27)

```
G      5000 lb
```

The indicator can be configured for many other outputs to match the application.

6 Error messages

The following error messages may be displayed during use of the indicator:

Message	Display
Overload	
Can't fit on display or load cell not properly connected	
Underload	
Can't	
Entry not in valid range	
Password entry failed	
Remote display not receiving data from the master indicator	
Indicator did not reach a stable zero weight within time window set for automated weighing process.	  
Indicates the battery is enabled and TMOU value is set but the indicator is not operating with the proper battery shutoff circuitry	

7 Supervisor menu

This menu allows a supervisor to change those functions of an application that are configurable. Access the supervisor menu using the password 1793. Refer to [Accessing the menus on page 35](#) for instructions.



Wherever there is an option to print information in the any of the supervisor's menus, the information will print out of Port 1, Port 2 or to USB, whichever is configured.



The menus are always explained in a sequential manner to cover all information in a logical fashion. You will probably never access all the menu items in this manner. You can navigate to the area of the menu that needs to be changed by using the navigation key chart shown with each menu.

The Supervisor menu changes based on the active application. Go to the appropriate section.

- [General Weighing application supervisor menu on page 50](#)
- [Accumulator application supervisor menu on page 58](#)
- [Counting application supervisor menu on page 62](#)
- [Checkweighing application supervisor menu on page 66](#)
- [Batching application supervisor menu on page 69](#)
- [Peak Hold application supervisor menu on page 77](#)
- [Remote Display application supervisor menu on page 79](#)
- [In-Motion application supervisor menu on page 81](#)

7.1 General Weighing application supervisor menu

Figure 7.1 shows the Supervisor menu when you are in the General Weighing application.

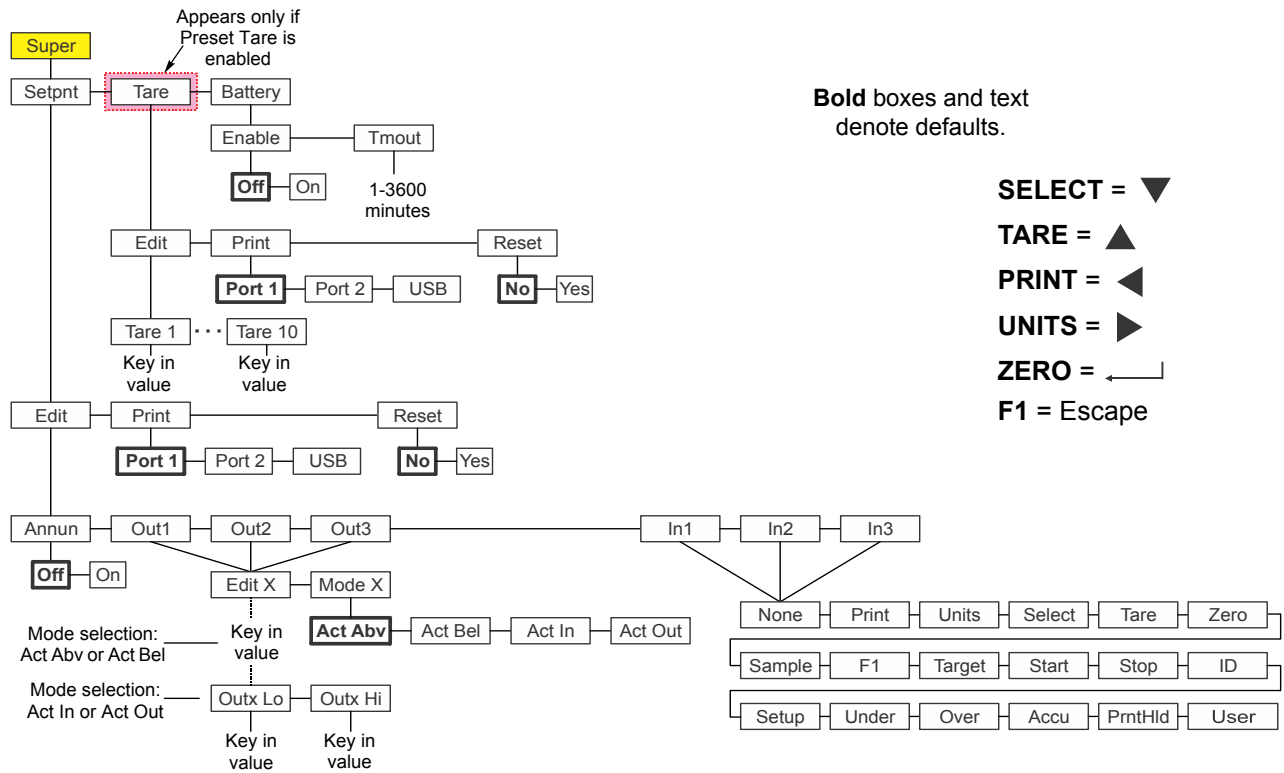

Figure 7.1 Supervisor menu for the General Weighing application



The Setpoint menu is the same for all the applications so will only be explained once here. Exceptions are noted in the text.

Follow these steps to set the items in the Supervisor menu.

7.1.1 Setpoint

Super↓ Setpoint

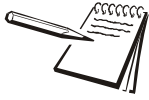

The ↓ and → symbols used in this section stand for direction moved in the menu. So Super ↓ Setpoint, shown above, illustrates that you move down from **SuPEr** to **SEtPnt**. This will help you keep track of where you are in the menu structure.



If you are using a battery operated indicator with any application, setpoint output #3 can be configured for shutting down the battery for power saving. See the Service manual for information on setting up setpoint outputs and optional power saving circuitry you can create to shutdown power from a battery. **The ZM-BAT (the optional D-cell battery pack) made for the ZM305 does not contain the power saving circuitry.**



A setpoint value can be entered ranging from +/- scale capacity. See [Entering a negative number on page 14](#) for the negative numeric entry process.

Turn off or disable any setpoints you are not using. See the Service manual for information on disabling or turning off setpoints.

1. With the General Weighing application active, access the Supervisor menu. Refer to [Accessing the menus on page 35](#) for instructions. From **SuPEr**, press **SELECT ...**

SEtPnt is displayed. Use this to:

- set the function of the setpoint annunciators
- enter up to three setpoint values
- select inputs for up to three inputs
- set the mode of setpoint operation
- print the setpoint settings
- reset all setpoint settings to factory defaults.

Annunciators

Setpoint ↓ Edit ↓ Annun

2. Press **SELECT ...**

Edit is displayed.

3. Press **SELECT ...**

Annun is displayed.

This stands for annunciators, referring to the *SP1*, *SP2* and *SP3* setpoint annunciators. By default (**oFF**) these annunciators are ON when the selected mode of the setpoint is active or OFF when the selected mode of the setpoint is not active. If you select **on**, the annunciators work in the opposite fashion--OFF when the selected mode is active or ON when the selected mode is not active.

4. Press **SELECT** ...
The current setting is displayed (**oFF** or **on**).
5. Press **UNITS** to toggle between the choices and when your choice is displayed, press **ZERO** to accept ...

Annun is displayed.

Outputs

Setpoint ↓ Edit ↓ Annun → Out

6. Press **UNITS** ...
out1 is displayed. This is the weight value for setpoint 1. You can access **out2** or **out3** by pressing the **UNITS** key. The following instructions apply to any of these three outputs.

7. Press **SELECT** ...

Edit X is displayed. **X** being the number of output.

8. Press **UNITS** ...

ModE X is displayed. This menu item sets the function of the output. Mode selection must be made before entering the Out value.

9. Press **SELECT** ...

The current Mode setting for the selected Output is displayed. The Mode settings are listed below:

Act AbV (default)	The output is active when the weight is above the set value
Act bEL	The output is active when the weight is below the set value
Act in	The output is active when the weight is inside of the low and high set values
Act out	The output is active when the weight is outside of the low and high set values

10. Press **UNITS** or **PRINT** to scroll through the choices shown above and then press **ZERO** to accept the displayed Mode ...

ModE X is displayed.

11. Press **UNITS** ...

Edit X is displayed. Set the value or values for the output under this menu item.

12. Press **SELECT** ...

If you selected Mode **Act AbV** or **Act bEL**, a value entry screen is displayed. Go to step 13.

If you selected Mode **Act in** or **Act out**, **outX Lo** is displayed. This is one of two value entry screens under **Edit X**. Go to step 14.

13. Key in a value the you want the output to activate above or below and press **ZERO** to accept the value.
Edit X is displayed. Go to step 18.
14. Key in a value for **outX Lo** and press **ZERO** to accept ...
outX Lo is displayed.
15. Press **UNITS** ...
outX Hi is displayed.
16. Key in a value for **outX Hi** and press **ZERO** to accept ...
outX Hi is displayed.
17. Press the **TARE** key ...
Edit X is displayed.
18. Press the **TARE** key ...
OutX is displayed.
19. Repeat steps 6 through 17 for **out2** and **out3**.

Inputs

Setpoint ↓ Edit ↓ Annun → Out → In

20. Press **UNITS** when finished ...
in1 is displayed. This stands for input 1. Use this to assign a function to input 1 when an external switch is tripped. Default choice is **nonE**. The choices are listed in [Figure 7.1](#).



Inputs are enabled (ON) in a separate password protected menu. Some input choices will not apply in the application that is active.

21. From **in1**, press **SELECT** ...
The current choice is displayed.
22. Press **UNITS** to scroll through the choices and when your choice is displayed, press **ZERO** to accept ...
in1 is displayed.
23. Press **UNITS** ...
in2 is displayed.
24. Repeat steps 21 through 23 for **in2** and **in3**.
25. Press **TARE** when finished ...
Edit is displayed.

Print

Setpoint ↓ Edit → Print

26. Press **UNITS** ...
Print is displayed. Use this to print the settings under **SEtPnt**.
27. Press **SELECT** ...
Port 1 is displayed.
28. Press **IN/OUT** to abort the print process or press **UNITS** to scroll to the desired port and press **ZERO** to print the information ...
Print is displayed after either action.

Reset

Setpoint ↓ Edit → Print → Reset

29. Press **UNITS** ...
rESEt is displayed. Use this to reset the settings under **Edit** to factory defaults.
30. Press **SELECT** ...
no is displayed.
31. Press **ZERO** to abort the reset or press **UNITS** ...
YES is displayed.
32. Press **ZERO** to reset the settings to factory defaults ...
rESEt is displayed.
33. Press **TARE** ...
SEtPnt is displayed.

7.1.2 Tare

Super ↓ Setpoint → Tare

If Preset Tare is not enabled, skip to step 7. If it is enabled continue to the next step.

1. Press **UNITS** ...
tArE is displayed.
Use this to:
 - set values for up to 10 preset tares
 - print the values of the preset tares
 - reset all preset tares to factory defaults of 0The following steps describe the procedures.

Tare Register 1-10

Tare ↓ Edit ↓ Tare 1-10

2. Press **SELECT** ...
Edit is displayed.
3. Press **SELECT** ...
tArE 1 is displayed. This is the first of the 10 preset tare values you can set.
4. Press **SELECT** ...
The current value is displayed with a flashing right digit.



If the active unit of measure is lb-oz then tare weights must be entered in the oz equivalent. To enter 2 lb 4.5 oz you would need to enter 36.5 oz (2 lb = 32 oz plus the 4.5)

5. Press **ZERO** to accept the displayed value or key in a new value and press **ZERO** to accept ...
tArE 1 is displayed.
6. Press **UNITS** ...
tArE 2 is displayed.
7. Repeat steps 4 through 6 for *tArE 2* through *tArE 10*. Press **TARE** when finished ...
Edit is displayed.

Printing

Tare ↓ Edit → Print

8. Press **UNITS** ...
Print is displayed. Use this to print the preset tare values.
9. Press **SELECT** ...
Port 1 is displayed.
10. Press **F1** to abort the print process or press **UNITS** to scroll to the desired port and press **ZERO** to print the information ...
Print is displayed after either action.

Reset

Tare ↓ Edit → Print → Reset

11. Press **UNITS** ...
rESEt is displayed. Use this to reset the all the preset tares to the factory default of 0.

12. Press **SELECT** ...
no is displayed.
13. Press **ZERO** to abort the reset or press **UNITS** ...
YES is displayed.
14. Press **ZERO** to reset the settings to factory defaults ...
rESEt is displayed.
15. Press **TARE** ...
tArE is displayed.

7.1.3 Battery

Super ↓ Setpoint → Tare → Battery

1. Press **UNITS** ...
bAttErY is displayed. Use this to enable the battery and to set a timeout length (in minutes). If this time expires with no scale or keypad activity, setpoint #3 will change states so the battery will shut off if the proper external circuitry is provided. See the Service manual.

Enable

Battery ↓ Enable



*Only enable the battery and set the **tMout** value if the battery has the proper external shutoff circuitry. If battery use is enabled, setpoint output 3 cannot be used for setpoints in any application. It is used as a shutoff signal.*

2. Press **SELECT** ...
EnAbLE is displayed. Choices are **oFF** and **on**. Choose **oFF** to disable battery usage. Choose **on** to enable battery usage.
3. Press **UNITS** to toggle between the choices and when your choice is displayed, press **ZERO** to accept ...
EnAbLE is displayed.

Timeout

Battery ↓ Enable → Timeout

4. Press **UNITS** ...
tMout is displayed. This stands for timeout. Use this to set the length of time before inactivity of the scale and keypad cause battery power to be shutoff. Values between 1 and 3600 minutes are valid. **This function only works if the battery has shutoff circuitry.**
5. Press **SELECT** ...
A numeric entry screen appears.

6. Key in a value, in minutes and press **ZERO** to accept ...
tMout is displayed.
7. This completes the Supervisor menu for General Weighing. Repeatedly press **TARE** until the indicator returns to normal weighing mode.
The current weight value is displayed.

7.2 Accumulator application supervisor menu

Figure 7.2 shows the Supervisor menu when you are in the Accumulator application:

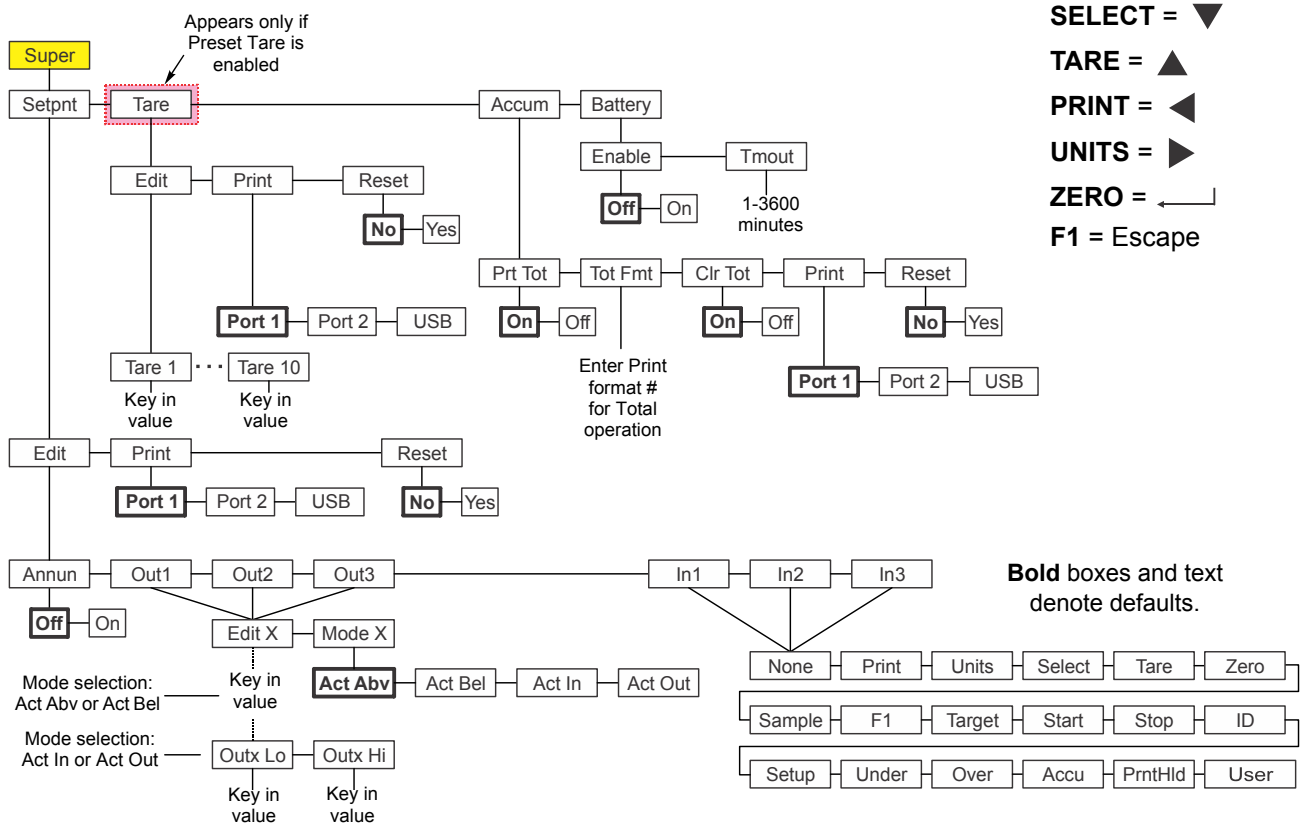

Figure 7.2 Supervisor menu for the Accumulator application

Follow these steps to set the items in the Supervisor menu.



The **Setpnt**, **Tare** and **bAttErY** submenus in Figure 7.2 are the same as described in [General Weighing application supervisor menu on page 50](#). Go there for information on those submenus. The unique submenus to this application are described below.

7.2.1 Accumulator

Super ↓ Setpoint → Tare → Accum

1. With the Accumulator application active, access the Supervisor menu using password 1793. Refer to [Accessing the menus on page 35](#) for instructions. From **SuPEr**, press **SELECT** ...

SEtPnt is displayed.

2. Press **UNITS** until ...

AccuM is displayed. Use this to set the items relating to accumulation. Under **AccuM** you can do the following:

- Enable/Disable the ability to print the accumulated total (**Prt tot**).
- Key in a print format number for printing the total accumulated weight information (**tot Fmt**).
- Enable/Disable the ability to clear the total accumulation information when the total is printed (**clr tot**).
- Print the accumulation report for all 200 memory channels (**Print**).
- Reset all 200 accumulator memory channel values to 0 (**rESEt**).

The following steps describe the procedure to set these items.

Print total

Accum ↓ Print Total

3. From **AccuM**, press **SELECT** ...

Prt tot is displayed. This stands for print total.

4. Press **SELECT** ...

oFF is displayed.

5. Press **ZERO** to keep the print total function disabled or press **UNITS** to toggle to **on** and press **ZERO** to enable printing of the accumulated total ...

Prt tot is displayed.

If enabled, during normal operation the user can press and hold **PRINT** for three seconds and the selected total print format (see step 8 below) will be sent out any port that is set up to printed. The display will flash **Prn-tot**.

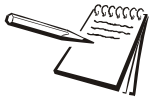

*If the Print Return to Zero setting is OFF (in the password protected menu), press and holding the **PRINT** key will force a print to occur before printing of the totals. If the setting is ON then a print will not occur and the display will show **cAnt** and then the totals will print.*

Total format

Accum ↓ Print Total → Total Format

6. Press **UNITS** ...

tot Fmt is displayed. This stands for the total print format.

7. Press **SELECT** ...

The current print format number is displayed with a flashing right-most digit. (Default is format 8)

8. Press **ZERO** to accept the existing setting or key in a new format number and press **ZERO** ...

tot Fmt is displayed.

Clear total

Accum ↓ Print Total → Total Format → Clear Total

9. Press **UNITS** ...

cLr tot is displayed. This stands for clear total. Choose **on** to enable clearing the accumulated total when printed. Choose **oFF** to disable this function.

If enabled, the total is cleared if the user presses and holds the **PRINT** key for three seconds. The message **cLr-tot** will flash. The total is printed prior to clearing if this was enabled in step 5 above.

10. Press **SELECT** ...

The current setting is displayed.

11. Press **UNITS** to toggle between the choices and when your choice is displayed, press **ZERO** to accept ...

cLr tot is displayed.

Print

Accum ↓ Print Total → Total Format → Clear Total → Print

12. Press **UNITS** ...

Print is displayed. This stands for print the accumulation report. Choose a port to print the accumulated totals report for all 200 memory channels.

13. Press **SELECT** ...

Port 1 is displayed.

14. Press **F1** to abort the print process or press **UNITS** to scroll to the desired port and press **ZERO** to print the information ...

Print is displayed after either action.

Reset

Accum ↓ Print Total → Total Format → Clear Total → Print → Reset

15. Press **UNITS** ...

rESEt is displayed. Use this to reset the all the items under **AccuM** to the factory defaults.

16. Press **SELECT** ...
no is displayed.
17. Press **ZERO** to abort the reset or press **UNITS** ...
YES is displayed.
18. Press **ZERO** to reset the settings to factory defaults ...
rESEt is displayed.
19. Press **TARE** ...
AccuM is displayed.
20. Press **UNITS** ...
bAttErY is displayed. The battery menu is identical in all the applications. Refer to step 1 on page 56 for information on setting up the battery.
21. This completes the Supervisor menu for the Accumulation application.
Repeatedly press **TARE** until the indicator returns to normal weighing mode.
The current weight value is displayed.

7.3 Counting application supervisor menu

Figure 7.3 shows the Supervisor menu when you are in the Counting application:

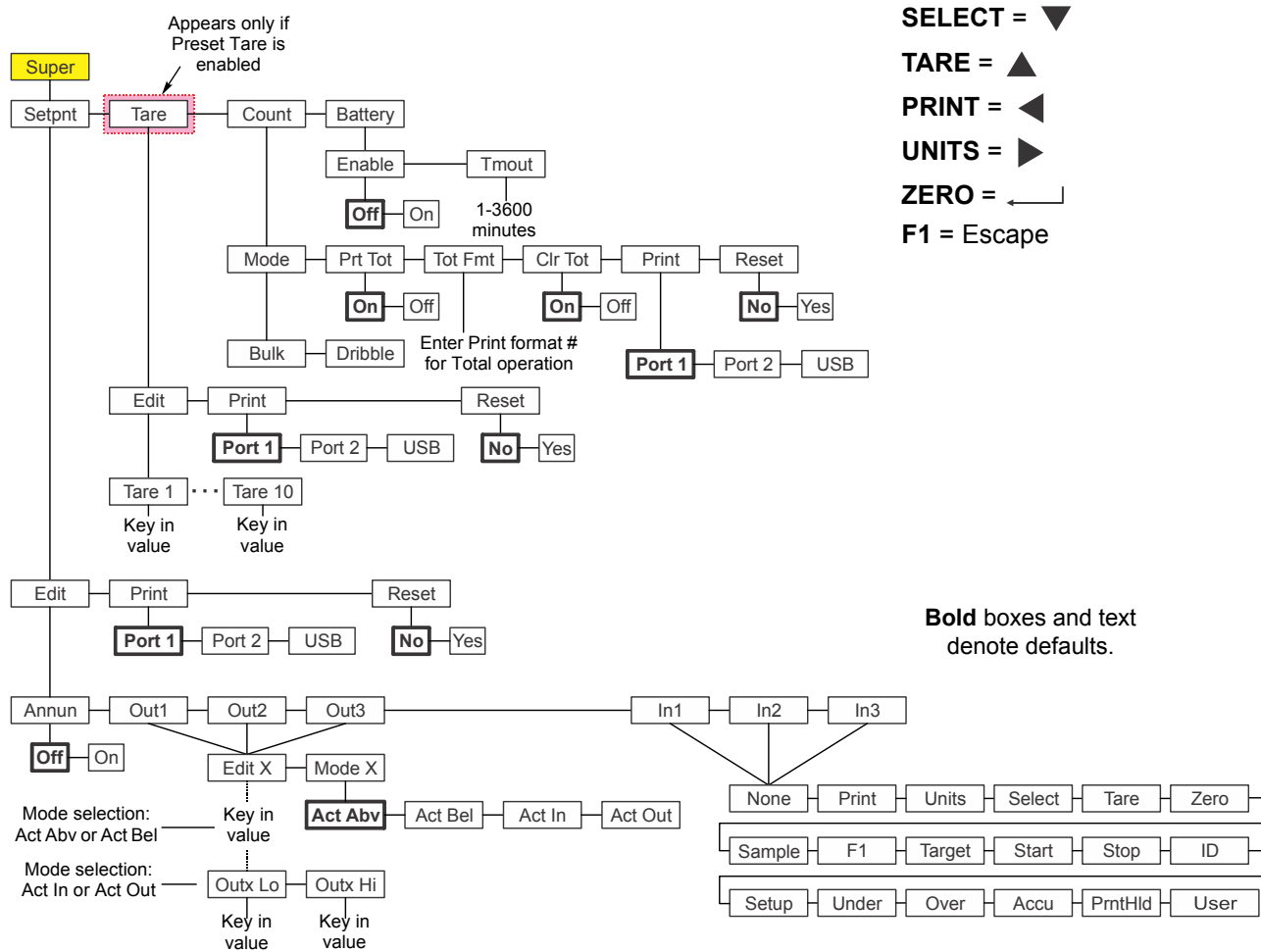

Figure 7.3 Supervisor menu for the Count application

Follow these steps to set the items in the Supervisor menu.



The **Setpnt**, **Tare** and **bAttErY** submenus in Figure 7.3 are the same as described in [General Weighing application supervisor menu on page 50](#). Go there for information on those submenus. The unique submenus to this application are described below.

7.3.1 Count

Super ↓ Setpoint → Tare → Count

1. With the Count application active, access the Supervisor menu using password 1793. Refer to [Accessing the menus on page 35](#) for instructions. From **SUPER**, press **SELECT** ...

SEtPnt is displayed.

2. Press **UNITS** twice ...

count is displayed. Use this to set the items relating to counting:

- Select between bulk and dribble mode.
- Enable/Disable the ability to print the count total (**Prt tot**).
- Key in a print format number for printing the total count information (**tot Fmt**).
- Enable/Disable the ability to clear the total count information when the total is printed (**clr tot**).

The following steps describe the procedure to set these items.

Mode

Count ↓ Mode

3. Press **SELECT** ...

ModE is displayed. There are two modes for sampling: **buLK** and **dribBLE**.

Bulk In bulk sampling you place the specified number of items on the scale all at once (in bulk) and the scale automatically starts to calculate piece weight when the weight stabilizes. The count is then displayed.

Dribble In dribble sampling method you count out the specified number of items onto the scale and when you are ready, press the **SAMPLE** key and the scale calculates piece weight and then shows the count.

4. With **ModE** displayed, press **SELECT** ...

buLK is displayed.

5. Press **UNITS** to toggle between the choices and when your choice is displayed, press **ZERO** to accept ...

ModE is displayed.

Print total

Count ↓ Mode → Print Total

6. Press **UNITS** ...

Prt tot is displayed. This stands for print total.

7. Press **SELECT** ...

on or **oFF** is displayed. Default is **on**.

8. Press **ZERO** when **on** is displayed to enable printing of the count total or press **UNITS** to toggle to **oFF** and press **ZERO** to keep the print total function disabled ...

Prt tot is displayed.

If enabled, during normal operation the user can press and hold **PRINT** for three seconds and the selected total print format (see step below) will be sent out any port that is set up to printed. The display will flash **Prn-tot**.

Total format

Count ↓ Mode → Print Total → Total Format

9. Press **UNITS** ...

tot Fmt is displayed. This stands for the total print format.

10. Press **SELECT** ...

The current print format number is displayed with a flashing right-most digit. (Default is format 31)

11. Press **ZERO** to accept the existing setting or key in a new format number and press **ZERO** ...

tot Fmt is displayed.

Clear total

Count ↓ Mode → Print Total → Total Format → Clear Total

12. Press **UNITS** ...

cLr tot is displayed. This stands for clear total. Choose **on** to enable clearing the count total when printed. Choose **oFF** to disable this function.

If enabled, the total is cleared if the user presses and holds the **PRINT** key for three seconds. The message **cLr-tot** will flash. The total is printed prior to clearing if this was enabled in step 8 above.

13. Press **SELECT** ...

The current setting is displayed.

14. Press **UNITS** to toggle between the choices and when your choice is displayed, press **ZERO** to accept ...

cLr tot is displayed.

Print

Count ↓ Mode → Print Total → Total Format → Clear Total → Print

15. Press **UNITS** ...

Print is displayed. This stands for print the count totals report. Choose a port to print the count totals report.

16. Press **SELECT** ...
Port 1 is displayed.
17. Press **F1** to abort the print process or press **UNITS** to scroll to the desired port and press **ZERO** to print the information ...
Print is displayed after either action.

Reset

Count ↓ Mode → Print Total → Total Format → Clear Total → Print → Reset

18. Press **UNITS** ...
rESet is displayed. Use this to reset the all the items under **count** to the factory defaults.
19. Press **SELECT** ...
no is displayed.
20. Press **ZERO** to abort the reset or press **UNITS** ...
YES is displayed.
21. Press **ZERO** to reset the settings to factory defaults ...
rESet is displayed.
22. Press **TARE** ...
count is displayed.
23. Press **UNITS** ...
bAttErY is displayed. The battery menu is identical in all the applications. Refer to step 1 on page 56 for information on setting up the battery.
24. This completes the Supervisor menu for the Count application. Repeatedly press **TARE** until the indicator returns to normal weighing mode.
The current weight value is displayed.

7.4 Checkweighing application supervisor menu

Figure 7.4 shows the Supervisor menu when you are in the Checkweighing application:

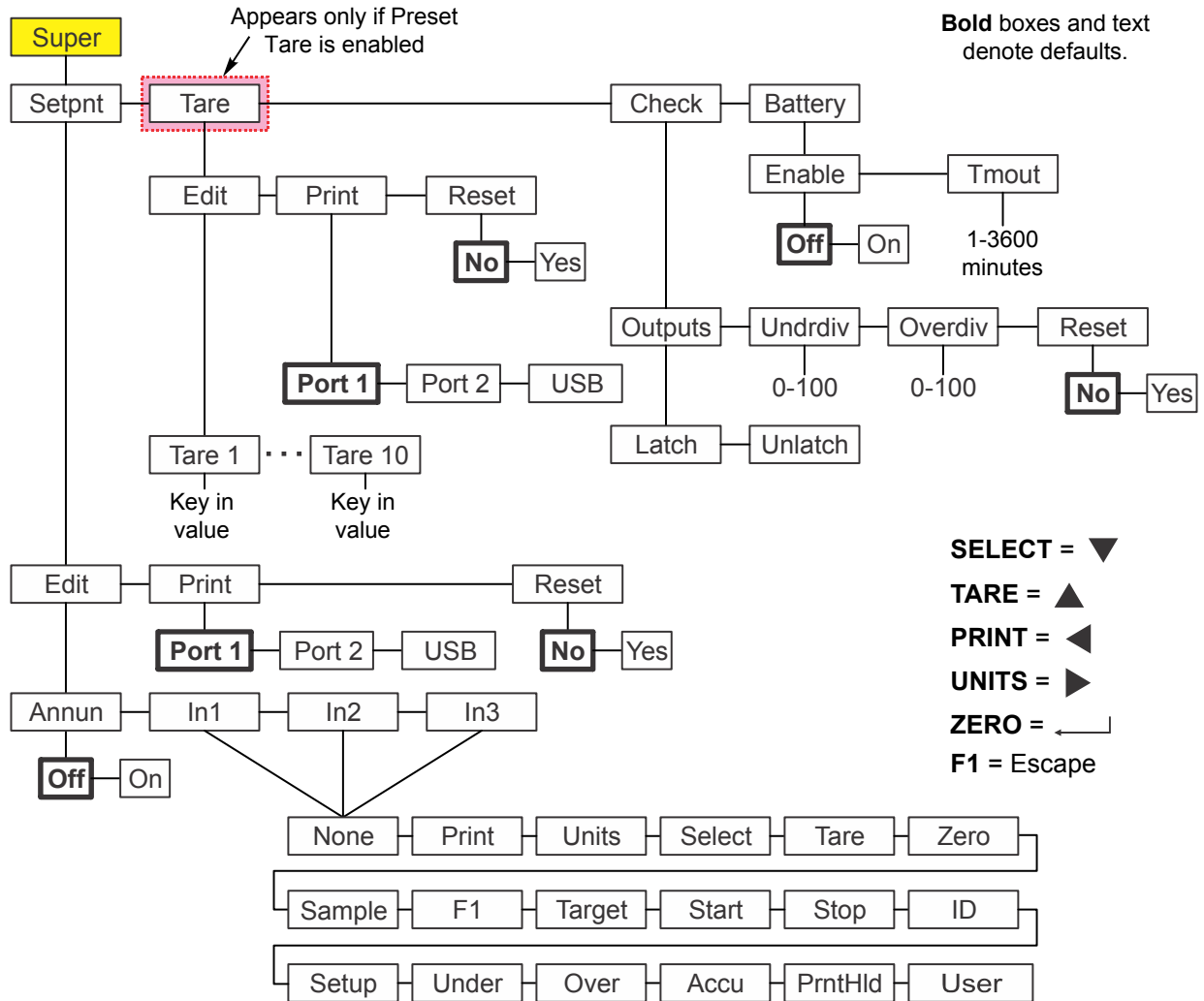
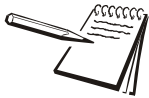

Figure 7.4 Supervisor menu for the Checkweighing application

Follow these steps to set the items in the Supervisor menu.



The **Setpnt**, **Tare** and **bAttErY** submenus in Figure 7.4 are the same as described in [General Weighing application supervisor menu on page 50](#). Go there for information on those submenus. The one exception is that **out1**, **out2** and **out3** are not in the **Setpnt** menu. They do not apply in the Checkweighing application. The unique submenus to this application are described below.



If Battery option is enabled (only necessary when the indicator is used with a battery shutdown circuit) in the check weighing application, Setpoint output #1 represents “Reject” (over & under conditions). Setpoint output #2 represents “Accept” (target). Setpoint output #3 is dedicated to battery shutoff circuitry. See the Service manual for information on setting up setpoint outputs.

7.4.1 Check

Super ↓ Setpoint → Tare → Check

1. With the Checkweighing application active, access the Supervisor menu using password 1793. Refer to [Accessing the menus on page 35](#) for instructions. From **SuPEr**, press **SELECT** ...

SEtPnt is displayed.

2. Press **UNITS** twice ...

chEcK is displayed. This stands for checkweigher. Use this to set the items relating to checkweighing:

- Set conditions for using the outputs. (**outPutS**)
- Set under divisions for acceptable target weight (**undrdiv**)
- Set over divisions for acceptable target weight (**oVERdiV**)
- Reset the target values to zero. (**rESEt**)

Outputs - Latch & Unlatch

Check ↓ Outputs ↓ Latch & Unlatch

3. Press **SELECT** ...

outPutS is displayed. There are two choices for outputs, **LA**tch and **unLA**tch. If you choose **LA**tch, this means that the weight has to stabilize before the annunciator and output for the appropriate condition (Under, Accept or Over) is activated. If you choose **unLA**tch, the annunciator and output will change instantly as the weight changes checkweigh condition.

In latch mode, once activated the annunciator and output will remain unchanged until the item is removed and the gross weight returns to inside the gross zero band.

4. From **outPutS**, press **SELECT** ...

LAtch is displayed.

5. Press **UNITS** to toggle between the choices and when your choice is displayed, press **ZERO** to accept ...

outPutS is displayed.



If the checkweigh mode is currently using the LO and HI limit values, viewing or entering the Under or Over division settings will change these Limit values accordingly.

Under divisions

Check ↓ Outputs → Under divisions

6. Press **UNITS** ...

undrdiv is displayed. Use this to set the number of divisions (0-100) below the target weight that is still within the accept window.

7. Press **SELECT** ...
The current value is shown with a flashing right-most digit.
8. Press **ZERO** to accept the current value or key in a new value and press **ZERO** to accept ...
undrdiv is displayed.

Over divisions

Check ↓ Outputs → Under divisions → Over divisions

9. Press **UNITS** ...
oVErdiV is displayed. Use this to set the number of divisions (0-100) above the target weight that is still within the accept window.
10. Press **SELECT** ...
The current value is shown with a flashing right-most digit.
11. Press **ZERO** to accept the current value or key in a new value and press **ZERO** to accept ...
oVErdiV is displayed.

Reset

Check ↓ Outputs → Under divisions → Over divisions → Reset

12. Press **UNITS** ...
rESEt is displayed. Use this to reset the all the checkweigher variables to the factory defaults.
13. Press **SELECT** ...
no is displayed.
14. Press **ZERO** to abort the reset or press **UNITS** ...
YES is displayed.
15. Press **ZERO** to reset the settings to factory defaults ...
rESEt is displayed.
16. Press **TARE** ...
chEcK is displayed.
17. Press **UNITS** ...
bAttErY is displayed. The battery menu is identical in all the applications. Refer to step 1 on page 56 for information on setting up the battery.
18. This completes the Supervisor menu for the Checkweighing application. Repeatedly press **TARE** until the indicator returns to normal weighing mode.
The current weight value is displayed.

Outputs

Setpoint ↓ Edit ↓ Out1

3. Press **SELECT** ...
out1 is displayed. This is the weight value for setpoint 1.
4. Press **SELECT** ...
The current value is displayed with a flashing right digit.
5. Press **ZERO** to accept the displayed value or key in a new value and press **ZERO** to accept ...
out1 is displayed.
6. Press **UNITS** ...
out2 is displayed.
7. Repeat steps 4 through 6 for **out2** and **out3**. Press **UNITS** when finished ...
PrEAct1 is displayed.

Preacts

Setpoint ↓ Edit ↓ Out → Preact

Preacts can be used to compensate for product weight that continues to fill into a bag or container after the setpoint output turns off and before the final weight stabilizes. Key in values for these items if Preacts are set to Manual or Auto. The values you enter are used in either case but for Auto preacts the value is adjusted automatically by the indicator as it runs multiple batches. In other words it learns what the correct preact should be.

The actual cutoff weight will equal the entered setpoint value minus the preact value.

8. With **PrEAct1** displayed, press **SELECT** ...
The current value is displayed for preact 1 (which is associated with output 1).
9. Press **ZERO** to accept the displayed value or key in a new value and press **ZERO** to accept ...
PrEAct1 is displayed.
10. Press **UNITS** ...
PrEAct2 is displayed.
11. Repeat steps 8 through 10 for **PrEAct2** and **PrEAct3**. Press **UNITS** when finished ...
In1 is displayed.

Inputs

Setpoint ↓ Edit ↓ Out → Preact → In

in1 stands for input 1. Use this to assign a function to input 1 when an external switch is tripped. Default choice is **nonE**. The choices are listed in [Figure 7.5](#).



Inputs and Outputs must be enabled ON in a separate password protected menu. Some input choices will not apply in the application that is active.

12. From **in1**, press **SELECT** ...

The current choice is displayed.

13. Press **UNITS** to scroll through the choices and when your choice is displayed, press **ZERO** to accept ...

in1 is displayed.

14. Press **UNITS** ...

in2 is displayed.

15. Repeat steps 12 through 14 for **in2** and **in3**.

16. Press **TARE** ...

Edit is displayed.

Print

Setpoint ↓ Edit → Print

17. Press **UNITS** ...

Print is displayed. Use this to print the settings under **SEtPnt**.

18. Press **SELECT** ...

Port 1 is displayed.

19. Press **IN/OUT** to abort the print process or press **UNITS** to scroll to the desired port and press **ZERO** to print the information ...

Print is displayed after either action.

Reset

Setpoint ↓ Edit → Print → Reset

20. Press **UNITS** ...

rESet is displayed. Use this to reset the settings under **Edit** to factory defaults.

21. Press **SELECT** ...

no is displayed.

22. Press **ZERO** to abort the reset or press **UNITS** ...
YES is displayed.
23. Press **ZERO** to reset the settings to factory defaults ...
rESEt is displayed.
24. Press **TARE** ...
SEtPnt is displayed.

7.5.2 Batch

Super ↓ Setpoint → Tare → Batch

1. With the Batching application active, access the Supervisor menu using password 1793. Refer to [Accessing the menus on page 35](#) for instructions. From **SuPEr**, press **SELECT** ...
SEtPnt is displayed.
2. Press **UNITS** twice ...
bAtch is displayed. Use this to set the items relating to batching:
 - Set the type of batch operation. (**tYPE**)
 - Select auto or manual operation. (**ModE**)
 - Set gross or net display mode. (**diSP**)
 - Set the conditions for preact. (**PrEAct**)
 - Select negative filling operation. (**nEG FIL**)

Type

Batch ↓ Type

3. Press **SELECT** ...
tYPE is displayed. There are 4 choices under Type: **2 SPEEd**, **iNGrEd**, **iNdEP** and **FIL-dSc**. Each is explained below:
 - 2 SPEEd** Choose 2 speed when you have one ingredient with a speed control device.
 - iNGrEd** Choose ingredient for sequential filling for up to 3 products at a single speed.
 - iNdEP** Choose independent when the filling process is run based on the values set for the outputs.
 - FIL-dSc** Choose fill-discharge when performing a fill operation (negative weight) from something like a hopper scale.
- See [Notes on batching on page 75](#) for information about settings for each of these types of batching.
4. Press **SELECT** ...
The current setting is displayed.

5. Press **UNITS** to scroll through the choices and when your choice is displayed, press **ZERO** to accept ...
tYPE is displayed.

Mode

Batch ↓ Type → Mode

6. Press **UNITS** ...
ModE is displayed. Mode has two choices: **Auto** or **MAnuAL**. There is a detailed description for each type in the section titled [Batching application on page 29](#)
7. Press **SELECT** ...
The current setting is displayed.
8. Press **UNITS** to toggle between the choices and when your choice is displayed, press **ZERO** to accept ...
ModE is displayed.

Display

Batch ↓ Type → Mode → Display

9. Press **UNITS** ...
diSP is displayed. Display has two choices: **NEt** or **GroSS**. Each is explained below:
NEt Choose Net to base batching on net weights.
GroSS Choose Gross to base batching on gross weights.
10. Press **SELECT** ...
The current setting is displayed.
11. Press **UNITS** to toggle between the choices and when your choice is displayed, press **ZERO** to accept ...
diSP is displayed.

Preact

Batch ↓ Type → Mode → Display → Preact

12. Press **UNITS** ...

PrEAct is displayed.

Preact can be used to compensate for product weight that continues to fill into the bag or container after the setpoint output turns off and before the final weight stabilizes. If a preact value is automatically calculated or manually entered, the actual cutoff weight will equal the entered setpoint value minus the preact value.

PrEAct has three choices: **Manual**, **Auto**, or **cLEAR**. Each is explained below:

Manual When **Manual**, the preact values entered in the SETPNT submenu for Preact 1, 2 and 3 are used.

Auto When set to **Auto**, preact is automatically calculated. The amount of compensation is calculated based on the average variance between the entered setpoint value and the actual fill weights recorded during the most recent batch cycles. Auto Preact is only available in certain Batch Types as noted in their descriptions. Calculated Preact values can be viewed in the SETPNT submenu for Preact 1, 2 and 3.

cLEAR When **cLEAR** is selected, the current preact values will be set to 0. If **PrEAct** was set to **Auto**, a new set of compensation values will be calculated on continuing batches. If preact was set to **Manual**, then preact will be disabled or new values can be manually entered in the setpoint menu.

13. Press **SELECT** ...

The current setting is displayed.

14. Press **UNITS** to scroll through the choices and when your choice is displayed, press **ZERO** to accept ...

PrEAct is displayed.

Negative fill

Batch ↓ Type → Mode → Display → Preact → Negative Fill

15. Press **UNITS** ...

NEG Fil is displayed. This stands for negative fill. This has two choices: **oFF** or **on**. Each is explained below:

Choose **oFF** to disable negative fill. (default)

Choose **on** to enable negative fill. Operation varies depending on Type chosen. See [Notes on batching on page 75](#).

16. Press **SELECT** ...

The current setting is displayed.

17. Press **UNITS** to scroll through the choices and when your choice is displayed, press **ZERO** to accept ...
NEG FiL is displayed.
18. Press **TARE** ...
bAtch is displayed.
19. Press **UNITS** ...
bAttErY is displayed. The battery menu is identical in all the applications. Refer to step 1 on page 56 for information on setting up the battery.
20. This completes the Supervisor menu for the Batching application. Repeatedly press **TARE** until the indicator returns to normal weighing mode.
The current weight value is displayed.

7.5.3 Notes on batching

2 Speed

MODE setting does not apply to 2 SPEED.

If **DISP** is set to **NET**, an autotare will occur prior to the start of the fill.

If **DISP** is set to **GROSS**, no autotare will occur and the fill cutoffs are based on actual Gross weight.

PREACT, if used, only affects the cutoff value of Out 2. See details of **PREACT** below.

If **NEG FILL** is set to **YES**, then **DISP** should be set to **NET** so that an autotare occurs prior to start and the cutoffs will be based on negative entered values for Out 1 and Out 2.

SP3 and Output 3 are used as the Active Batch Cycle indicator in 2 Speed filling

Ingredient



*If the **START** button is pressed during the batch cycle, the current ingredient fill will be terminated and the batch cycle will continue to the next ingredient fill.*

If **MODE** is set to **AUTO**, the batch process will continue until the final ingredient is completed. Between each ingredient there will be a slight delay to allow for motion, final weight and preact calculations.

If **MODE** is set to **MANUAL**, this requires that you press **F1** or **START** between each ingredient to complete the fill cycle.

If **MODE** is set to **MANUAL** and **DISP** is set to **NET**, then you must also press **TARE** between each ingredient before pressing **START** to fill the next ingredient.

If **MODE** is set to **AUTO** and **DISP** is set to **NET**, an autotare will occur prior to each ingredient and the Out 1, 2 and 3 fill weights will be based on Net weight.

If **DISP** is set to **GROSS**, no autotare will occur and the Out 1, 2 and 3 fill weights would be based on the Gross weight of the accumulated ingredients. If Ingredient 1 amount is 10, Ingredient 2 amount is 20 and ingredient 3 amount is 30 then you would enter Out 1 = 10, Out 2 = 30 (10 + 20) and Out 3 = 60 (10 + 20 + 30). Output cutoffs are based on the actual displayed Gross weight so if inaccurate amounts of ingredient are experienced during the batch then it may affect the amount of each subsequent ingredient that is added.

If **PREACT** is set to **AUTO**, then it will be calculated for each ingredient to adjust the cutoff weight accordingly.

If **NEG FILL** is set to **YES**, it will only operate for a single ingredient with OUT 1 used for discharge filling based on negative weight.

Independent Setpoints

Out 1, 2 and 3 values operate the Outputs independently. Press **F1** or **START** for initial start.

MODE setting does not apply to INDEPENDENT setpoints.

If **DISP** is set to **NET**, this uses net weight and if **DISP** is set to **GROSS**, this uses gross weight for cutoff value

Auto **PREACT** is not available in INDEPENDENT filling.

If **NEG FILL** is set to **YES**, this allows operation of Out 1, 2 and 3 values in negative weight mode.

Fill/Discharge

MODE setting does not apply to Fill/Discharge

If **DISP** is set to **NET**, the display will remain in net weight mode after the discharge cycle.

If **DISP** is set to **GROSS**, the display will switch to gross weight mode after the discharge cycle.

If **PREACT** is set to **AUTO** it only applies during the Out 2 discharge cycle.

NEG FILL setting does not apply to Fill/Discharge

7.6 Peak Hold application supervisor menu

Figure 7.6 shows the Supervisor menu when you are in the Peak Hold application:

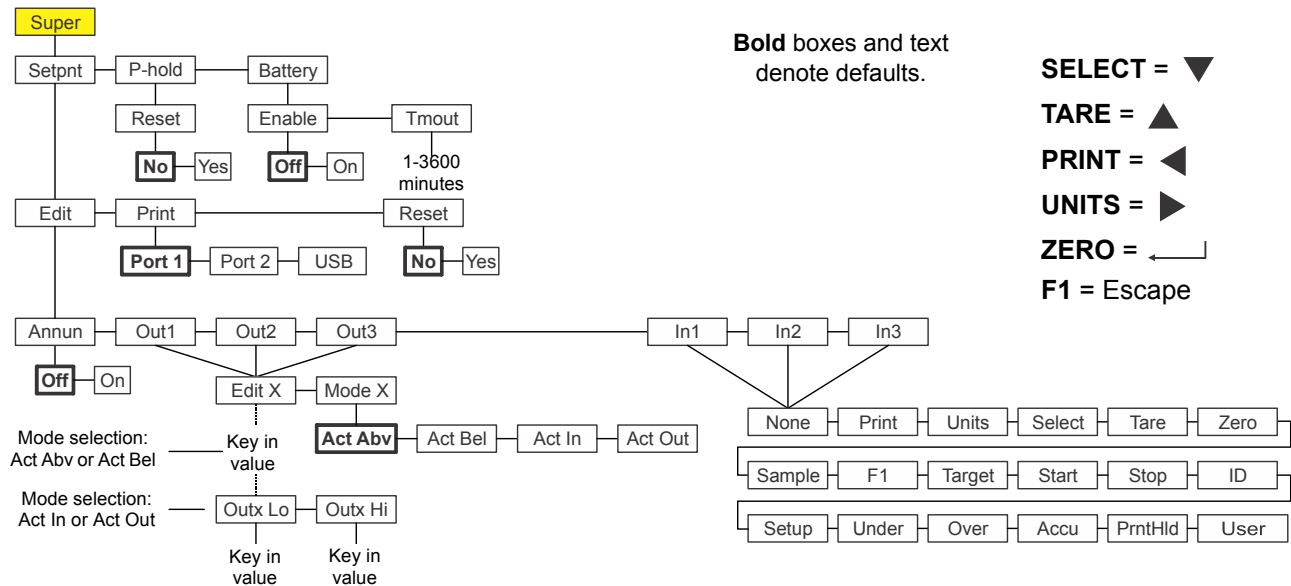

Figure 7.6 Supervisor menu for the Peak Hold application



The *Setpnt* and *bAttErY* submenus in Figure 7.6 are the same as described in [General Weighing application supervisor menu on page 50](#). Go there for information on those submenus. The unique submenus to this application are described below.

7.6.1 Peak hold

Super ↓ Setpoint → P-hold

1. With the Peak Hold application active, access the Supervisor menu using password 1793. Refer to [Accessing the menus on page 35](#) for instructions. From **SuPEr**, press **SELECT** ...

SEtPnt is displayed.

2. Press **UNITS** twice ...

P-hoLd is displayed. Use this to reset the min/max peak. If the **F1** key is disabled, which is the normal key to reset min/max, the supervisor needs an alternate method to reset these values.

Reset

P-hold ↓ Reset

3. Press **SELECT** ...

rESEt is displayed.

4. Press **SELECT** ...
no is displayed.
5. Press **UNITS** to toggle between the **no** and **YES** choices. Press **ZERO** to accept...
The min/max are reset and **rESEt** is displayed.
6. Press **TARE** repeatedly to return to normal weighing operation.

7.7 Remote Display application supervisor menu

To configure the indicator for remote display operation you must choose the mode of operation in the supervisor menu and configure the port. Configuring the port is done through a password protected menu. Contact your supervisor or your local Avery Weigh-Tronix representative for more information.

Figure 7.7 shows the Supervisor menu when you are in the Remote Display application:

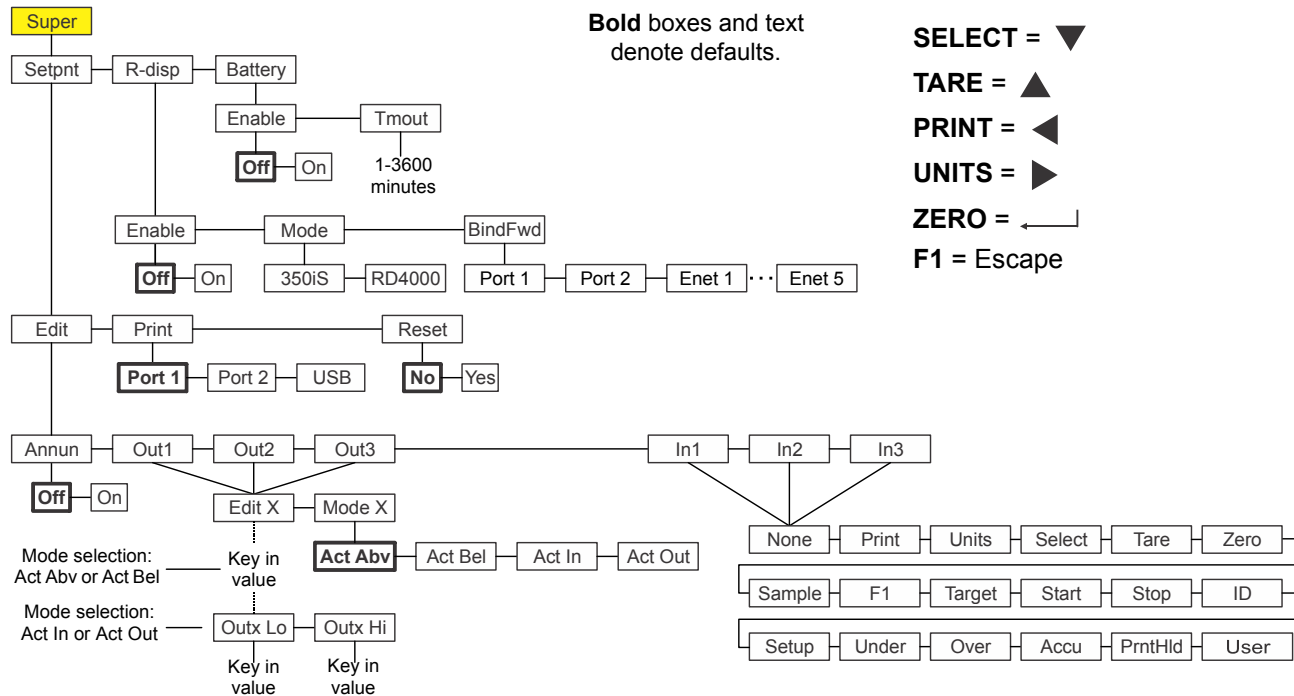

Figure 7.7 Supervisor menu for the Remote Display application



The *Setpnt* and *bAttErY* submenus in Figure 7.7 are the same as described in [General Weighing application supervisor menu on page 50](#). Go there for information on those submenus. The unique submenu to this application is described below.

1. With *r-diSP* displayed press **SELECT** ...

EnAbLE is displayed. Use this to enable or disable the remote display function. Choices are **OFF** (disable) or **on** (enable).

2. Press **SELECT** ...

The current setting is displayed.

3. Press **UNITS** to toggle between the choices and press **ZERO** to accept the displayed choice ...

EnAbLE is displayed.

4. Press **UNITS** ...

MoDE is displayed. Choices are **350iS** or **rd4000**. Choose which type of remote display protocol to receive.

5. Press **SELECT** ...

The current setting is displayed.

6. Press **UNITS** to toggle between the choices and press **ZERO** to accept the displayed choice ...

ModE is displayed.

7. Press **UNITS** ...

bindFwd is displayed. Choose which port will be used for printing/communication forwarding from the Main indicator. Choices are **Port 1**, **Port 2**, **Enet1** through **Enet 5**.



BindFwd only works when the unit is setup as a remote display with a GSE 350IS which is configured for forwarding Print information

8. Press **SELECT** ...

The current setting is displayed.

9. Press **UNITS** to scroll through the choices and press **ZERO** to accept the displayed choice ...

bindFwd is displayed.

10. This completes the Supervisor menu for the Remote Display application. Repeatedly press **TARE** until the indicator returns to normal weighing mode.

The current weight value is displayed.

The indicator can be configured to work as a remote display with other compatible indicators or the GSE 350/355IS.

Settings in two password protected menus must be made to configure the indicator for remote display operation. Contact your local Avery Weigh-Tronix representative for information on setting up the Primary and Secondary indicator.



Additional operation information can be found in [Remote display application on page 33](#).

7.8 In-Motion application supervisor menu

Figure 7.8 shows the Supervisor menu when you are in the In-Motion application:

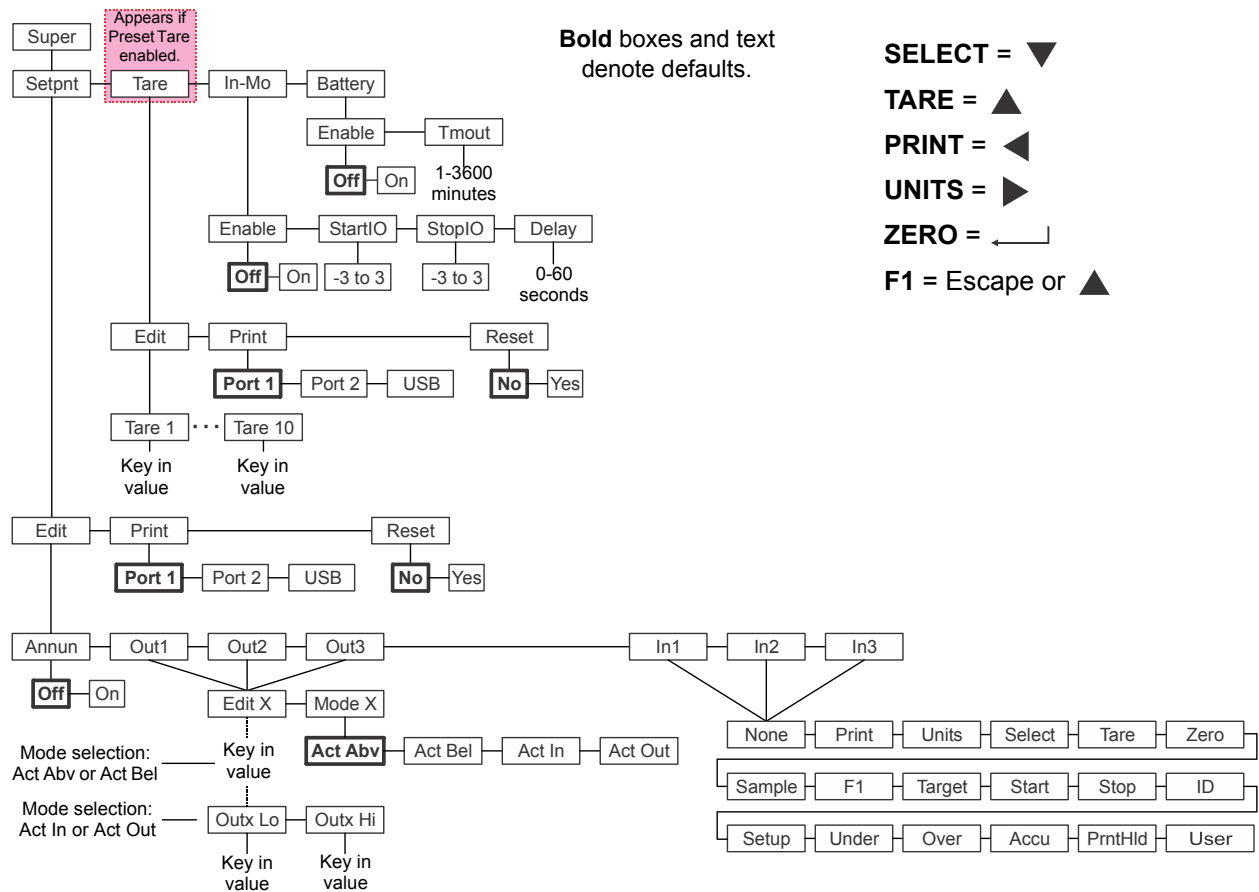

Figure 7.8 Supervisor menu for the In-Motion application



The **Setpnt**, **tArE** and **bAttErY** submenus in Figure 7.8 are the same as described in [General Weighing application supervisor menu on page 50](#). Go there for information on those submenus. The unique submenu to this application is described below.

7.8.1 In-Motion



Setpoints are based off of the In Motion averaged weight.

The second Photo Eye activates when the item being weighed is exiting the scale. This triggers the PRINT KEY FUNCTION at the firmware level. All Protocols using the Type selection set to PRINT will activate and send the print format data you have defined to the Ports they are Bind to.

Additional information on the photo-eye hardware and wiring is found in the following manual [CVC_w_ZM_i_en_501403.pdf](#) The ZM305 can also be used with Mono-Rails and Weigh-Legs for in-motion weighing applications.

Super ↓ Setpoint → Tare → In-Mo

1. With the In-Motion application active, access the Supervisor menu using password 1793. Refer to [Accessing the menus on page 35](#) for instructions. From **SuPEr**, press **SELECT** ...
SEtPnt is displayed.
2. Press **UNITS** twice ...
in-Mo is displayed. This stands for in-motion. Use this to set the items relating to in-motion weighing.
3. Press **SELECT** ...
EnAbLE is displayed. Use this item to enable or disable in-motion weighing. If enabled you must set the other parameters in this menu.
4. To enable or disable, press **SELECT** ...
The current setting **OFF** (default) or **on** is displayed.
5. Press **UNITS** to toggle between the choices and press **ZERO** to accept the displayed choice ...
EnAbLE is displayed.
6. Press **UNITS** ...
StArtio is displayed. Use this item to setup the incoming or 'start' photo-eye so the weight averaging will begin to be captured by the indicator.
7. Press **SELECT** ...
A value entry screen is displayed. You can key in values related to the input port that will be connected to the entrance photo eye circuit and whether it is a positive going transition (positive value) or negative going transition (negative value). This makes your choices: **-3, -2, -1, 1, 2, or 3**. The number you use is determined by the photo-eye you are using. Consult the photo-eye manual for the correct setting. To enter a negative value see [Entering a negative number on page 14](#).
8. With the value displayed, press the **ZERO** key to accept ...
StArtio is displayed.

9. Press **UNITS** ...

StoPio is displayed. Use this item to setup the outgoing or 'stop' photo-eye so the weight averaging will cease to be captured by the indicator.
10. Press **SELECT** ...

A value entry screen is displayed. You can key in values related to the input port that will be connected to the exit photo eye circuit and whether it is a positive going transition or negative going transition. This makes your choices: **-3, -2, -1, 1, 2, or 3**. The number you use is determined by the photo-eye you are using. Consult the photo-eye manual for the correct setting. To enter a negative value see [Entering a negative number on page 14](#).
11. When the value is displayed, press the **ZERO** key to accept ...

StoPio is displayed.
12. Press **UNITS** ...

dDELAY is displayed. Use this item to enter the maximum time in seconds that the average weight is displayed after the item breaks the exit photo-eye. If another item breaks the entrance photo-eye before the time is up, the displayed weight is cleared early.

If zero is chosen, the weight is displayed until the next item breaks the entrance photo-eye beam.

This value is also used for how long the setpoint outputs will remain activated after the exit photo eye is tripped.
13. Press **SELECT** ...

A value entry screen is displayed. Key in a delay time of 0-60 seconds. Zero means the indicator will wait until the next package or forever.
14. When the value is displayed, press the **ZERO** key to accept ...

dDELAY is displayed.
15. This completes the Supervisor menu for the In-motion application. Repeatedly press **TARE** until the indicator returns to normal weighing mode.

The current weight value is displayed.

Supervisor menu

Avery Weigh-Tronix



Avery Weigh-Tronix USA

1000 Armstrong Dr.

Fairmont MN 56031 USA

Tel:507-238-4461

Fax:507-238-4195

Email: usinfo@awtxglobal.com

www.averyweigh-tronix.com

Avery Weigh-Tronix UK

Foundry Lane,

Smethwick, West Midlands,

England B66 2LP

Tel:+44 (0) 8453 66 77 88

Fax:+44 (0)121 224 8183

Email: info@awtxglobal.com

www.averyweigh-tronix.com