

ZM305 GTN Inbound-Outbound Indicator



User Instructions

Avery Weigh-Tronix is a trademark of the Illinois Tool Works group of companies whose ultimate parent company is Illinois Tool Works Inc (“Illinois Tool Works”). Copyright © 2015 Illinois Tool Works. All rights reserved.

No part of this publication may be reproduced by making a facsimile copy, by the making of a copy in three dimensions of a two-dimensional work and the making of a copy in two dimensions of a three-dimensional work, stored in any medium by electronic means, or transmitted in any form or by any means, including electronic, mechanical, broadcasting, recording or otherwise without the prior written consent of the copyright owner, under license, or as permitted by law.

This publication was correct at the time of going to print, however Avery Weigh-Tronix reserves the right to alter without notice the specification, design, price or conditions of supply of any product or service at any time.

Table of Contents

	<i>page</i>
Table of Contents	3
Chapter 1 General information and warnings	5
About this manual	5
Text conventions	5
Special messages	5
Installation	5
Safe handling of equipment with batteries	6
Wet conditions	6
Routine maintenance	6
Cleaning the machine	7
Training	7
Sharp objects	7
FCC and EMC declarations of compliance	8
Declarations of Conformity	9
Chapter 2 Introduction	11
Front panel	12
Keys	12
Annunciators	13
Powering up the ZM305	14
Entering a negative number	14
Chapter 3 Truck In/Out Operation	15
General weighing	15
Gross weighing	15
Net weighing	15
Using Pushbutton Tare	16
Truck inbound-outbound operations	18
IN/OUT key operation	18
FLEET key operation	19
REPORT key operation	20
Using setpoints	21
Printing	23
ID Entry	23
Traffic light controls	23
START key	23
STOP key	23
Chapter 4 Menus	24
Accessing the menus	24
Menu annunciators	24
Exiting the menus	25
USER level menus	25
User menu	26
Time	26
Date	27
Site ID	28
Seal	28
About menu	29
Boot	29
Firm and App	30

Serial	30
Option	30
Enet	31
Dload	32
Audit menu	33
Counter	33
Print	34
Chapter 5 Communications	35
Default print formats	35
Report Printout Samples	36
Chapter 6 Error messages	38
General messages	38
Truck scale database CSV file import/export messages	39
Chapter 7 Supervisor menu	40
Setpoint	41
Tare	44
Truck	46
Battery	55

1 General information and warnings

1.1 About this manual

This manual is divided into chapters by the chapter number and the large text at the top of a page. Subsections are labeled as shown by the 1.1 and 1.1.1 headings. The names of the chapter and the next subsection level appear at the top of alternating pages of the manual to remind you of where you are in the manual. The manual name and page numbers appear at the bottom of the pages.

1.1.1 Text conventions

Key names are shown in **bold** and reflect the case of the key being described. If a key has a dual function it may be referred to by its alternate function.

Displayed messages appear in ***bold italic*** type and reflect the case of the displayed message.

Annunciator names appear as *italic* text and reflect the case of the annunciator.

1.1.2 Special messages

Examples of special messages you will see in this manual are defined below. The signal words have specific meanings to alert you to additional information or the relative level of hazard.



CAUTION!

This is a Caution symbol.

Cautions give information about procedures that, if not observed, could result in damage to equipment or corruption to and loss of data.



NOTE: *This is a Note symbol. Notes give additional and important information, hints and tips that help you to use your product.*

1.2 Installation



NO USER SERVICEABLE PARTS. REFER TO QUALIFIED SERVICE PERSONNEL FOR SERVICE.

1.2.1 Safe handling of equipment with batteries



CAUTION: *Danger of explosion if battery is incorrectly replaced. Replace only with the same or equivalent type recommended by the manufacturer. Dispose of used batteries according to the manufacturer's instructions.*

ATTENTION: *Il y a danger d'explosion s'il y a remplacement incorrect de la batterie, remplacer uniquement avec une batterie du même type ou d'un type équivalent recommandé par le constructeur. Mettre au rebut les batteries usagées conformément aux instructions du fabricant.*

1.2.2 Wet conditions

Under wet conditions, the plug must be connected to the final branch circuit via an appropriate socket / receptacle designed for washdown use.

Installations within the USA should use a cover that meets NEMA 3R specifications as required by the National Electrical Code under section 410-57. This allows the unit to be plugged in with a rain tight cover fitted over the plug.

Installations within Europe must use a socket which provides a minimum of IP56 protection to the plug / cable assembly. Care must be taken to make sure that the degree of protection provided by the socket is suitable for the environment.

1.3 Routine maintenance



IMPORTANT: *This equipment must be routinely checked for proper operation and calibration. Application and usage will determine the frequency of calibration required for safe operation.*

Always isolate the indicator from the power supply before starting any routine maintenance to avoid the possibility of electric shock.

1.4 Cleaning the machine

Table 1.1 Cleaning DOs and DON'Ts



DO	DO NOT
Wipe down the outside of standard products with a clean cloth, moistened with water and a small amount of mild detergent	Attempt to clean the inside of the machine
	Use harsh abrasives, solvents, scouring cleaners or alkaline cleaning solutions
Spray the cloth when using a proprietary cleaning fluid	Spray any liquid directly on to the display windows

1.5 Training

Do not attempt to operate or complete any procedure on a machine unless you have received the appropriate training or read the instruction books.

To avoid the risk of RSI (Repetitive Strain Injury), place the machine on a surface which is ergonomically satisfactory to the user. Take frequent breaks during prolonged usage.

1.6 Sharp objects

Do not use sharp objects such as screwdrivers or long fingernails to operate the keys.

1.7 FCC and EMC declarations of compliance

United States

This equipment has been tested and found to comply with the limits for a Class A digital device, pursuant to Part 15 of the FCC Rules. These limits are designed to provide reasonable protection against harmful interference when the equipment is operated in a commercial environment. This equipment generates, uses, and can radiate radio frequency energy and, if not installed and used in accordance with the instruction manual, may cause harmful interference to radio communications. Operation of this equipment in a residential area is likely to cause harmful interference in which case the user will be required to correct the interference at his own expense.

Canada

This digital apparatus does not exceed the Class A limits for radio noise emissions from digital apparatus set out in the Radio Interference Regulations of the Canadian Department of Communications.

Le présent appareil numérique n'émet pas de bruits radioélectriques dépassant les limites applicables aux appareils numériques de la Classe A prescrites dans le Règlement sur le brouillage radioélectrique édicté par le ministère des Communications du Canada.

European Countries

WARNING: This is a Class A product. In a domestic environment, this product may cause radio interference in which the user may be required to take adequate measures.

1.8 Declarations of Conformity

Avery Weigh-Tronix

Foundry Lane, Smethwick, West Midlands B66 2LP, England

	Declaration of Conformity	Konformitätserklärung
	Verklaring van Overeenstemming	Dichiarazione di conformità
	Déclaration de Conformité	Declaración de Conformidad

Manufacturer Type	Avery Weigh-Tronix ZM305
No. of EC type approval certificate	UK 2923
corresponds to the requirements of the following EC directives:	
EMC Directive	2004/108/EC
Low Voltage Directive	2006/95/EC
Non-Automatic Weighing Instruments Directive	2009/23/EC ¹
The applicable harmonised standards are:	
EN 45501 : 1994 EN 60950-1 : 2006 +A12:2011	EN61000-6-4:2007
<p>Note 1: This declaration is only valid if the non-automatic weighing instrument was verified by the manufacturer or with a certificate of conformity issued by a notified body.</p> <p>ITW Ltd trading as Avery Weigh-Tronix Foundry Lane, Smethwick, West Midlands, B66 2LP, England</p> <p>Reg. Office: Admiral House, St Leonards Road, Berkshire SL4 3BL, England Registered in England No. 00559693</p>	

Fabrikant Type	Avery Weigh-Tronix ZM305
Nummer van de Verklaring van EG-typegoedkeuring	UK 2923
is in overeenstemming met de voorschriften van de volgende EG richtlijnen:	
EMC Richtlijn	2004/108/EG
Laagspanningsrichtlijn	2006/95/EG
Richtlijn niet-automatische weegwerktuigen	2009/23/EG ¹
Toegepaste geharmoniseerde normen:	
EN 45501 : 1994 EN 60950-1 : 2006 +A12:2011	EN61000-6-4:2007
<p>Noot 1: Deze verklaring is alleen geldig indien het weegwerktuig door de fabrikant is geverifieerd, of met een Verklaring van overeenstemming, afgegeven door een bevoegde instantie.</p> <p>ITW Ltd trading as Avery Weigh-Tronix Foundry Lane, Smethwick, West Midlands, B66 2LP, England</p> <p>Reg. Office: Admiral House, St Leonards Road, Berkshire SL4 3BL, England Registered in England No. 00559693</p>	

Fabricant Type	Avery Weigh-Tronix ZM305
No. de certificat d'approbation de type CE	UK 2923
correspond aux exigences des directives CE suivantes :	
Directive CEM	2004/108/CE
Directive Basse Tension	2006/95/CE
Directive pour les instruments de pesage à fonctionnement non automatique	2009/23/CE ¹
Les normes harmonisées applicables sont :	
EN 45501 : 1994 EN 60950-1 : 2006 +A12:2011	EN61000-6-4:2007
<p>Nota 1 : Cette déclaration est valide seulement si l'instrument de pesage à fonctionnement non automatique a été vérifié par le fabricant ou avec une attestation de conformité délivrée par un organisme notifié.</p> <p>ITW Ltd trading as Avery Weigh-Tronix Foundry Lane, Smethwick, West Midlands, B66 2LP, England</p> <p>Reg. Office: Admiral House, St Leonards Road, Berkshire SL4 3BL, England Registered in England No. 00559693</p>	

Hersteller Typ	Avery Weigh-Tronix ZM305
Nr. der EG-Bauartzulassung	UK 2923
entspricht den Anforderungen folgender EG-Richtlinien:	
EMV-Richtlinie	2004/108/EG
Niederspannungs Richtlinie	2006/95/EG
Waagenrichtlinie für nichtselbsttätige Waagen	2009/23/EG ¹
Die angewendeten harmonisierten Normen sind:	
EN 45501 : 1994 EN 60950-1 : 2006 +A12:2011	EN61000-6-4:2007
<p>Anmerkung 1: Diese Erklärung gilt nur, wenn die nichtselbsttätige Waage vom Hersteller geeicht wurde oder in Verbindung mit einer Konformitätsbescheinigung einer benannten Stelle.</p> <p>ITW Ltd trading as Avery Weigh-Tronix Foundry Lane, Smethwick, West Midlands, B66 2LP, England</p> <p>Reg. Office: Admiral House, St Leonards Road, Berkshire SL4 3BL, England Registered in England No. 00559693</p>	

Produttore Modello	Avery Weigh-Tronix ZM305
N. di certificato di approvazione di tipo CE	UK 2923
è conforme alle caratteristiche previste dalle seguenti direttive CE:	
Normativa EMC	2004/108/CE
Normativa per la bassa tensione	2006/95/CE
Normativa per strumenti di pesatura non automatici	2009/23/CE ¹
Le norme standard armonizzate e nazionali applicate sono:	
EN 45501 : 1994 EN 60950-1 : 2006 +A12:2011	EN61000-6-4:2007
<p>Nota 1: Questa dichiarazione è valida solamente se lo strumento di pesatura non automatico è stato verificato dal produttore o provvisto di un certificato di conformità rilasciato da un ente riconosciuto.</p> <p>ITW Ltd trading as Avery Weigh-Tronix Foundry Lane, Smethwick, West Midlands, B66 2LP, England</p> <p>Reg. Office: Admiral House, St Leonards Road, Berkshire SL4 3BL, England Registered in England No. 00559693</p>	

Fabricante Tipo	Avery Weigh-Tronix ZM305
Número del certificado de aprobación de tipo CE	UK 2923
conforme a las exigencias de las siguientes directivas CE:	
Directiva CME	2004/108/CE
Directiva de baja tensión	2006/95/CE
Directiva para equipos de pesaje no automáticos	2009/23/CE ¹
Las normas armonizadas en vigor son:	
EN 45501 : 1994 EN 60950-1 : 2006 +A12:2011	EN61000-6-4:2007
<p>Nota 1: Esta declaración es válida solamente si el equipo de pesaje no automático ha sido verificado por el fabricante o con certificado de conformidad emitido por un organismo notificado.</p> <p>ITW Ltd trading as Avery Weigh-Tronix Foundry Lane, Smethwick, West Midlands, B66 2LP, England</p> <p>Reg. Office: Admiral House, St Leonards Road, Berkshire SL4 3BL, England Registered in England No. 00559693</p>	

Signature/Name Handtekening/Naam Signature/Nom Unterschrift/Name Firma/Nome Firma/Nombre		Authorized signatory for Avery Weigh-Tronix Namens van Avery Weigh-Tronix Signataire autorisé d'Avery Weigh-Tronix Unterschriftsberechtigter für Avery Weigh-Tronix Firmatorio autorizzato per Avery Weigh-Tronix Firmante autorizado para Avery Weigh-Tronix	Date Datum Date Datum Data Fecha
	K. Detert Global Head of R&D		30 June 2014

76501-390 Issue 1

Avery Weigh-Tronix

Foundry Lane, Smethwick, West Midlands B66 2LP, England

	Declaration of Conformity Verklaring van Overeenstemming Déclaration de Conformité	Konformitätserklärung Dichiarazione di conformità Declaración de Conformidad
---	---	---

Manufacturer	Avery Weigh-Tronix
Type	ZM305 Automatic Gravimetric Filling Instrument
No. of EC type approval certificate	UK/0126/0122
corresponds to the requirements of the following EC directives:	
Measuring Instruments Directive	2004/22/EC
EMC Directive	2004/108/EC
Low Voltage Directive	2006/95/EC
The applicable harmonised standards are:	
OIML R61 EN 60950-1 : 2006 +A12:2011	EN 61000-6-4:2007
ITW Ltd trading as Avery Weigh-Tronix Foundry Lane, Smethwick, West Midlands, B66 2LP, England Reg. Office: Admiral House, St Leonards Road, Berkshire SL4 3BL, England Registered in England No. 00559693	

Fabrikant	Avery Weigh-Tronix
Type	ZM305 Automatic Gravimetric Filling Instrument
Nummer van de EG-onderzoeks certificaat	UK/0126/0122
is in overeenstemming met de voorschriften van de volgende EG richtlijnen:	
Richtlijn betreffende meetinstrumenten	2004/22/EG
EMC Richtlijn	2004/108/EG
Laagspanningsrichtlijn	2006/95/EG
Toegepaste geharmoniseerde normen:	
OIML R61 EN 60950-1 : 2006 +A12:2011	EN 61000-6-4:2007
ITW Ltd trading as Avery Weigh-Tronix Foundry Lane, Smethwick, West Midlands, B66 2LP, England Reg. Office: Admiral House, St Leonards Road, Berkshire SL4 3BL, England Registered in England No. 00559693	

Fabricant	Avery Weigh-Tronix
Type	ZM305 Automatic Gravimetric Filling Instrument
No. de certificat d'approbation de type CE	UK/0126/0122
correspond aux exigences des directives CE suivantes :	
Directive relative aux instruments de mesure	2004/22/CE
Directive CEM	2004/108/CE
Directive Basse Tension	2006/95/CE
Les normes harmonisées applicables sont :	
OIML R61 EN 60950-1 : 2006 +A12:2011	EN 61000-6-4:2007
ITW Ltd trading as Avery Weigh-Tronix Foundry Lane, Smethwick, West Midlands, B66 2LP, England Reg. Office: Admiral House, St Leonards Road, Berkshire SL4 3BL, England Registered in England No. 00559693	

Hersteller	Avery Weigh-Tronix
Typ	ZM305 Automatic Gravimetric Filling Instrument
Nr. der EG-Bauartprüfscheins	UK/0126/0122
entspricht den Anforderungen folgender EG-Richtlinien:	
Richtlinie für Messgeräte	2004/22/EG
EMV-Richtlinie	2004/108/EG
Niederspannungs Richtlinie	2006/95/EG
Die angewendeten harmonisierten Normen sind:	
OIML R61 EN 60950-1 : 2006 +A12:2011	EN 61000-6-4:2007
ITW Ltd trading as Avery Weigh-Tronix Foundry Lane, Smethwick, West Midlands, B66 2LP, England Reg. Office: Admiral House, St Leonards Road, Berkshire SL4 3BL, England Registered in England No. 00559693	

Produttore	Avery Weigh-Tronix
Modello	ZM305 Automatic Gravimetric Filling Instrument
N. di certificato di approvazione di tipo CE	UK/0126/0122
è conforme alle caratteristiche previste dalle seguenti direttive CE:	
Direttiva relativa agli strumenti di misura	2004/22/CE
Normativa EMC	2004/108/CE
Normativa per la bassa tensione	2006/95/CE
Le norme standard armonizzate e nazionali applicate sono:	
OIML R61 EN 60950-1 : 2006 +A12:2011	EN 61000-6-4:2007
ITW Ltd trading as Avery Weigh-Tronix Foundry Lane, Smethwick, West Midlands, B66 2LP, England Reg. Office: Admiral House, St Leonards Road, Berkshire SL4 3BL, England Registered in England No. 00559693	

Fabricante	Avery Weigh-Tronix
Tipo	ZM305 Automatic Gravimetric Filling Instrument
Número del certificado de aprobación de tipo CE	UK/0126/0122
conforme a las exigencias de las siguientes directivas CE:	
Directiva relativa a los instrumentos de medida	2004/22/CE
Directiva CME	2004/108/CE
Directiva de baja tensión	2006/95/CE
Las normas armonizadas en vigor son:	
OIML R61 EN 60950-1 : 2006 +A12:2011	EN 61000-6-4:2007
ITW Ltd trading as Avery Weigh-Tronix Foundry Lane, Smethwick, West Midlands, B66 2LP, England Reg. Office: Admiral House, St Leonards Road, Berkshire SL4 3BL, England Registered in England No. 00559693	

Signature/Name Handtekening/Naam Signature/Nom Unterschrift/Name Firma/Nome Firma/Nombre	 K. Detert Global Head of R&D	Authorised signatory for Avery Weigh-Tronix Namens van Avery Weigh-Tronix Signataire autorisé d'Avery Weigh-Tronix Unterschriftsberechtigter für Avery Weigh-Tronix Firmatorio autorizzato per Avery Weigh-Tronix Firmante autorizado para Avery Weigh-Tronix	Date Datum Date Datum Data Fecha
		30 June 2014	

2 Introduction

This manual covers the use of the ZM305 GTN (Gross/Tare/Net) Inbound-Outbound indicator shown in [Figure 2.1](#). The indicator comes in a stainless steel housing with the IBN display for high contrast in indoor or outdoor use.

The indicator is designed to interface with an electronic weigh bridge in a Truck Inbound-Outbound situation. Its purpose is to record inbound and outbound truck weights to calculate net weight value which can be transmitted by a USB port, 2 serial COM ports or an Ethernet port. Analog Output, Current Loop/RS485/RS422, USB Device and Wireless Ethernet 802.11g internal module cards are available options. One module card option can be installed at a time.

Also available is the STVS option for Severe Transient Voltage Suppression.

The ZM305 can connect to USB flash drives, printers, remote displays, computers and other peripheral devices.

The indicator also has three logic level inputs with configurable functions and three set point outputs. See the Specification literature for a full list of specifications.

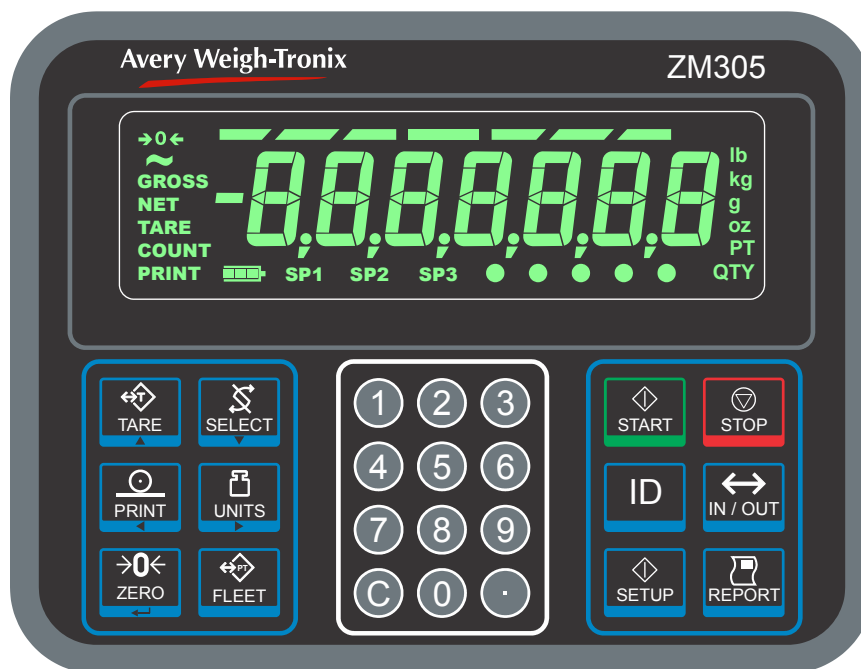

Figure 2.1 Front panel of the ZM305 Inbound-Outbound indicator

2.1 Front panel











The front panel, shown in [Figure 2.1](#), consists of the keys and display.





Never press a key with anything but your finger. Damage to the overlay may result if sharp or rough objects are used.

2.1.1 Keys

The normal function of the keys on the front panel are listed below.

	Press the TARE key to perform a tare function. Also prompts for a keyboard tare, if enabled. Acts as an up arrow key for menu navigation.
	Press the SELECT key to toggle between the active display values. Press and hold to enter the setpoint editor. Acts as a down arrow key for menu navigation.
	Press the PRINT to send information to a peripheral device through a configured communications port. Acts as a left arrow key for menu navigation.
	Press the UNITS key to scroll through the available units of measure while in normal operating mode. Acts as a right arrow key for menu navigation.
	Press the ZERO key to zero the display. Acts as an ENTER key to accept a displayed value or function.
	Press the FLEET key to enter a Fleet truck ID. Press and hold to clear a Fleet Truck sequence.
	Press the START key to change optional traffic light status to green.
	Press the STOP key to change optional traffic light status to red.
	Press ID to show the current ID value. Press and hold ID to enter a new ID value.
	Press the IN/OUT key to enter an Inbound/Outbound truck ID. Aborts a numeric entry and acts as an ESCAPE key for some of the menu navigation. Press and hold to clear an In/Out Truck sequence.

	Press the SETUP key to access the setpoint editor. Press and hold to view the password entry screen for menu access.
	Press the REPORT key to access the Reports menu.
	Use the numeric keypad to enter numbers in the appropriate screens. Press the C (CLEAR) key to clear the last entry.

2.1.2 Annunciators

The annunciators on the display are shown and labeled in [Figure 2.2](#).

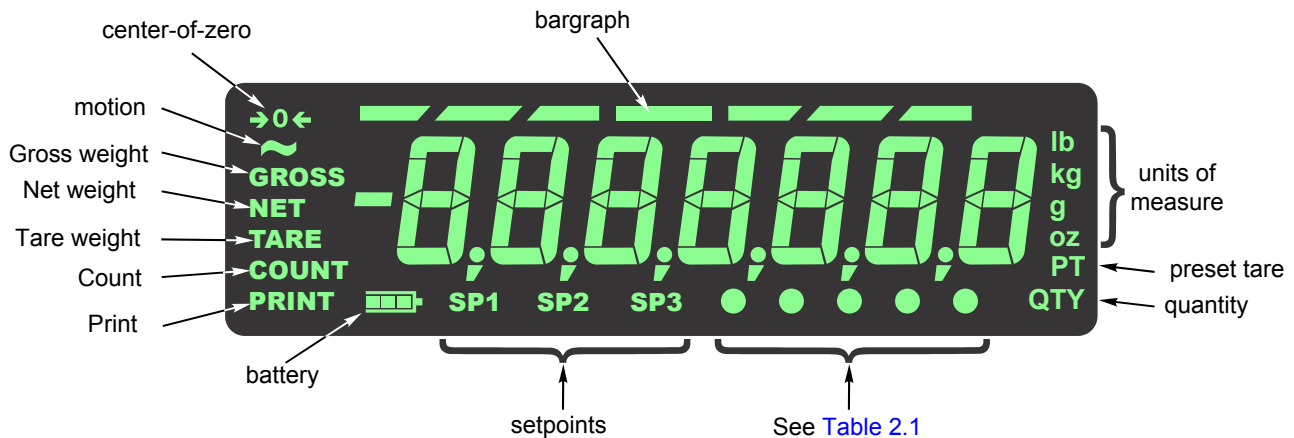

Figure 2.2 Annunciators

These annunciators will light during operation to inform the user of the weighing mode, active unit of measure, etc.

Table 2.1 Circle Annunciator assignments

Annunciator	Indicates
Circle 1 (left most)	Network activity
Circle 2	Custom unit
Circle 3	Pieceweight
Circle 3 & 4	Minimum
Circle 4 & 5	Maximum

2.2 Powering up the ZM305

The indicator is always active as long as power is received. Power can be supplied by:

- AC power cord connected to a properly grounded outlet (100 VAC - 240 VAC, 50 or 60 Hz)
- ZM-BAT - Optional external non-charging battery pack with 4 D cells
- DC power source (12 to 36 VDC)

2.3 Entering a negative number

To enter a negative number, press the **C** key to clear the current value from the display. With only one digit displayed press **SELECT**. The first character will be the (-) negative sign. Enter the rest of the digits normally.

3 Truck In/Out Operation

This chapter covers the operation of the ZM305 truck scale indicator.



*You can view the gross, net and tare display values by repeatedly pressing the **SELECT** key.*

3.1 General weighing

This section covers general weighing: Gross, tare and net weighing.

3.1.1 Gross weighing



*To change unit of measure, press **UNITS**.*

To perform gross weighing, power up the unit and follow these steps:

1. Empty the scale and press **ZERO** to zero the display ...
 0 is displayed and the *center-of-zero* annunciator lights.
2. Place item to be weighed on the scale ...
 Weight is displayed.
3. Repeat steps [1](#) and [2](#).

3.1.2 Net weighing

Net weighing is available via three types of tare entry.

Pushbutton tare When enabled press **TARE** to tare the weight on the scale.

Entered tare When enabled key in a tare weight and press **TARE** to set.

Preset tare When enabled press **TARE** to recall a preset tare numbered 1-10.



Pushbutton and Entered Tares can be enabled simultaneously. If Preset Tare is enabled, Pushbutton and Entered Tares are automatically disabled.

There is an auto tare clear feature. If this is enabled, after a weighment, when the weight falls into the gross zero band, tare is cleared to zero.



Definition: Gross zero band - this is a configured value that defines a window around gross zero. This is used in several ways in different applications.

The three types of tare are explained below.

3.1.3 Using Pushbutton Tare

To perform a net weighment using pushbutton tare, power up the unit and follow these steps:

1. Place item to be tared on the scale ...
Weight is displayed.
2. Press **TARE** ...
0 is displayed and the *NET* annunciator lights.
3. Place material to be weighed into or on the tared item on the scale ...
Net weight of material is displayed.
4. Repeatedly press **SELECT** to view the gross, tare, and net values.
5. If repeated weighments use the same tared item, you do not need to establish a new tare value as described in step 1 and 2.
6. To clear a tare value, press and hold the **TARE** key until ...
cLEARed is displayed.

Using Entered Tare

To perform a net weighment using entered tare, the following steps describe a typical operation:

1. With no weight on the scale, if the display does not read **0** press **ZERO** ...
0 is displayed and the *center-of-zero* annunciator lights.
2. Key in the tare value of the container or box that will be used to hold the material that requires a net weight value, and press **TARE** ...
Tare weight is displayed as a negative value and the *NET* annunciator lights.
3. Place the container or box and material to be weighed on the scale ...
Net weight of material is displayed.
4. If repeated weighments use the same tared item, you do not need to establish a new tare value as described in step 2.
5. To remove the tare weight from the scale, enter **0**, then press **TARE** ...
The tare is cleared and the scale is in gross weigh mode.

Using Preset Tare

Preset tares are available if entered in a password protected menu by a supervisor. There can be up to 10 tares numbered 1-10. To perform a net weighment using one of the preset tares, follow these steps:

1. With no weight on the scale, if the display does not read **0** press **ZERO** ...
0 is displayed and the *center-of-zero* annunciator lights.
2. Press **TARE** ...
Tare number entry screen appears.
3. Key in the preset tare number and press **ZERO** ...
Tare weight is displayed as a negative value and the *NET* annunciator lights.
4. Place container or box and material to be weighed on the scale ...
Net weight of material is displayed.
5. Repeat step 4 until you are finished using that tare weight.
6. To clear a tare value, press and hold **TARE** until ...
cLEARed is displayed.



Tare is removed automatically if Auto Tare Clear is enabled.



If the active unit of measure is lb-oz then tare weights must be entered in the oz equivalent. To enter 2 lb 4.5 oz you would need to enter 36.5 oz (2 lb = 32 oz plus the 4.5)

3.2 Truck inbound-outbound operations

This indicator is designed to streamline the collecting of net weights from inbound and outbound trucks. Use the **IN/OUT** key for transactions involving non-Fleet trucks. Use the **FLEET** key for transactions involving Fleet Trucks that already have a stored tare weight.

Until a Truck ID is entered the **PRINT** key can be used for General weighing transactions using the configured protocols. Once a Truck ID is entered the **PRINT** key will be associated with an Inbound or Outbound Ticket transaction.

3.2.1 IN/OUT key operation

1. Press the **IN/OUT** key to perform a Truck Inbound or Outbound transaction. The indicator must be in the gross weight mode or the message **cAnt** is displayed momentarily.

truckId is briefly displayed followed by the last active truck ID (last digit is flashing)

2. Press **ZERO** to accept the displayed ID...

OR

Use the numeric keypad to enter a different Truck ID and press **ZERO** to accept ...

When entering the Truck ID:

- If the ID is already in use as a Fleet truck, the display will show **cAnt** then **FLEETId** and then return to the weight screen.
- If the ID does not have a stored Inbound transaction the display will show **inbnd** (proceed to step 1)
- If the ID has a stored Inbound transaction the display will show **outbnd** (proceed to step 2)

Inbound transaction (1st weighment)

1. When the truck is on the scale and weight is stable press **PRINT** to store and print the Inbound transaction. Below is an example of an Inbound ticket:

```
~~~~~  
In Date 07-21-2014  
In Time 1:21 PM  
Truck ID 123  
In Weight 18580 lb  
~~~~~
```

Outbound transaction (2nd weighing)

- When the truck is on the scale and weight is stable press **PRINT** to update totals for this Truck ID and print the Outbound transaction. Below is an example of an Outbound ticket:

```

%%%%%%%%%%%%%%%%%%%%%%%%%%%%%%%%%%%%%%%%%%%%%%%%%%%%%%%%%%%%%%%%%%%%%%%%
In Date 07-21-2014
In Time 1:21 PM
Out Date 07-21-2014
Out Time 2:55 PM
Truck ID 123
Transaction      1

Gross      47820 lb
Tare       18580 lb
Net        29240 lb
%%%%%%%%%%%%%%%%%%%%%%%%%%%%%%%%%%%%%%%%%%%%%%%%%%%%%%%%%%%%%%%%%%%%%%%%

```

- If the Truck I/O transaction is no longer required, press and hold the **IN/OUT** key until **io cLr** is displayed to exit from the Truck I/O mode. The **PRINT** key can again be used for General weighing operation.

3.2.2 FLEET key operation

Until a Fleet Truck ID is entered the **PRINT** key can be used for General weighing transactions using the configured protocols. Once a Fleet Truck ID is entered the **PRINT** key will be associated with a Fleet Ticket transaction.

- Press the **FLEET** key to perform transactions for Fleet trucks that have an assigned tare weight.

FLEETid is briefly displayed followed by the last active truck ID (last digit is flashing)

- Press **ZERO** to accept the displayed ID ...

OR

Use the numeric keypad to enter a different Fleet ID. Press **ZERO** to accept ...

When entering the Fleet ID:

- If the ID exists as a valid Fleet Truck the display will show **FLEET** momentarily and the **PT** (preset tare) annunciator lights as the stored Fleet Truck Tare weight is loaded into the active Tare. If no truck is on the scale the stored Tare will be displayed as a negative weight.
- If an entered Fleet ID does not exist, the display will show **not Fnd** momentarily. Fleet IDs must be entered in the Supervisor menu before they can be used.
- If the entered ID is associated with a Truck I/O record the display will show **cAnt** and **io id** briefly and then return to the weigh screen.

Fleet transaction

1. When the truck is on the scale and weight is stable press **PRINT** to update totals for this Fleet ID and print the Fleet transaction. Below is an example of a Fleet ticket:

```
~~~~~  
Date 07-21-2014  
Time 09:45 am  
Fleet ID 123  
Transaction 1  
  
Gross 47820 lb  
Tare 18580 lb PT  
Net 29240 lb  
~~~~~
```

2. If the Fleet transaction is no longer required press and hold the **FLEET** key until **FLt cLr** is displayed to exit from the Fleet mode. The **PRINT** key can again be used for General weighing operation.

3.2.3 REPORT key operation

The REPORT key allows you to print four different printed reports: **rEPrint**, **in rPt**, **out rPt**, and **FLt rPt**. Follow these steps to print a report.

1. Press the **REPORT** key ...
rEPrint is displayed.
2. Use the **UNITS** or **PRINT** key to scroll through the other three choices. When your choice is displayed, press the **ZERO** key to print the report. Below are explanations for each report:

rEPrint	This choice reprints the last Inbound, Outbound or Fleet transaction ticket. The line ----- REPRINT ----- will be added to the bottom of the ticket. The data is an exact duplicate of the last printout.
in rPt	Prints the report of all the Trucks that have recorded an Inbound transaction but have yet to complete the Outbound transaction. Individual or all Inbound records can be cleared in the Supervisor menu.
out rPt	Prints the report of all the Truck ID's and associated totals that have completed an Outbound transaction. Individual or all Outbound records can be deleted in the Supervisor menu.
FLt rPt	Prints the report of all the Fleet Truck ID's and tare weights and associated totals. Individual or all Fleet records can be deleted in the Supervisor menu.

3.2.4 Using setpoints

Setpoints are values (weight) at which outputs are triggered automatically. Outputs can control relays connected to valves, lights, other machinery, etc. Setpoint outputs can be configured in the setpoint menu shown in [Figure 3.1](#).

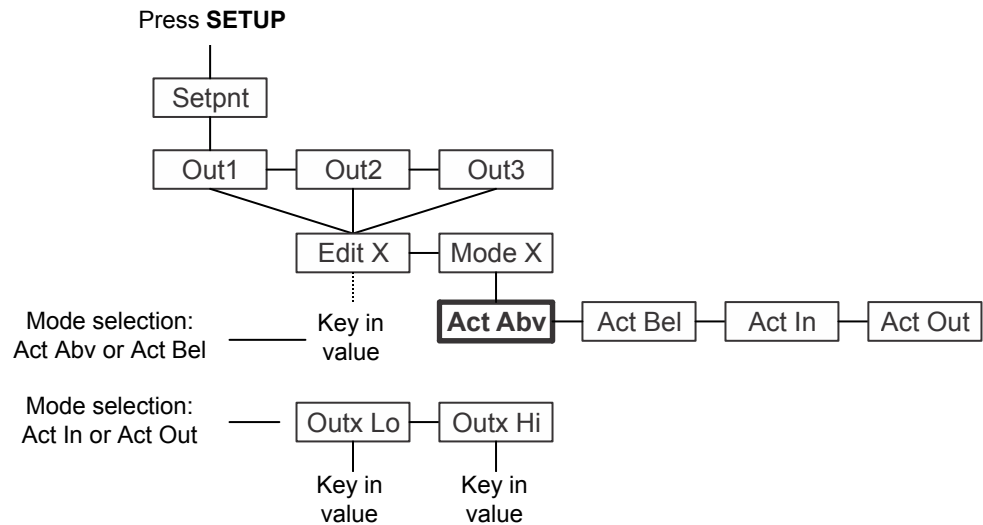

Figure 3.1 Setpoint menu



Default Setpoint operation

Mode = Active Above

Outputs must be enabled for setpoints to operate. See the **Service Manual**:

Below Configured Value:

Outputs are OFF

Annunciators are OFF

Above Configured Value:

Outputs are ON

Annunciators are ON

The setpoint outputs and setpoint annunciators logic state can be inverted from their default settings. Refer to details in the password protected menu settings in the section titled [Setpoint on page 41](#).

Follow these steps to configure the outputs:

1. Press **SETUP** ...

out1 is displayed. This is the weight value for setpoint 1. You can access **out2** or **out3** by pressing the **UNITS** key. The following instructions apply to any of these three outputs.

2. Press **SELECT** ...

Edit X is displayed. **X** being the number of output.

3. Press **UNITS** ...

Mode X is displayed. This menu item sets the function of the output. Mode selection must be made before entering the Out value.

4. Press **SELECT** ...

The current Mode setting for the selected Output is displayed. The Mode settings are listed below:

Act AbV (default)	The output is active when the weight is above the set value
Act bEL	The output is active when the weight is below the set value
Act in	The output is active when the weight is inside of the low and high set values
Act out	The output is active when the weight is outside of the low and high set values

5. Press **UNITS** or **PRINT** to scroll through the choices shown above and then press **ZERO** to accept the displayed Mode ...

ModE X is displayed.

6. Press **UNITS** ...

Edit X is displayed. Set the value or values for the output under this menu item.

7. Press **SELECT** ...

If you selected Mode **Act AbV** or **Act bEL**, a value entry screen is displayed. Go to step 8.

If you selected Mode **Act in** or **Act out**, **outX Lo** is displayed. This is one of two value entry screens under **Edit X**. Go to step 9.

8. Key in a value the you want the output to activate above or below and press **ZERO** to accept the value.

Edit X is displayed. Go to step 13.

9. Key in a value for **outX Lo** and press **ZERO** to accept ...

outX Lo is displayed.

10. Press **UNITS** ...

outX Hi is displayed.

11. Key in a value for **outX Hi** and press **ZERO** to accept ...

outX Hi is displayed.

12. Press the **TARE** key ...

Edit X is displayed.

13. Press the **TARE** key ...

OutX is displayed.

14. Repeat steps 1 through 12 for **out2** and **out3**.

15. Press **TARE** repeatedly to return to normal weighing mode with the setpoints active.

3.2.5 Printing

If a Truck IO or Fleet transaction is in process, when **PRINT** is pressed the associated ticket print format will be transmitted through the configured port.

If a Truck transaction is not in process then when you press the **PRINT** key, the configured print format will be output through the configured port to the connected peripheral device. The indicator can be configured to only allow one print for each weighing sequence. If **PRINT** is pressed when so configured, **cAnt** is displayed instead of printing again.

Refer to [Default print formats on page 35](#).

Printing any of the configured print formats is possible using the Numbered Print feature. Enter the print format number and then press the **PRINT** key. The selected print format will be transmitted out all ports that are configured to print. This feature is disabled during a Truck In/Out transaction sequence. If the Truck transaction is no longer required, press and hold the **IN/OUT** or **FLEET** key to reset the transaction sequence.

3.2.6 ID Entry

An ID can be entered for use with transmitted or printed transactions. Press and hold the **ID** key and the message **id** is displayed followed by the current ID value. Enter up to seven digits (numeric only) and press **ZERO**. To review press the ID key and the active ID will be displayed for a few seconds before returning to normal operation.

3.3 Traffic light controls

Additional traffic light control information can be found under **Lite** in the Supervisor menu found on page [51](#).

3.3.1 START key

The **START** key will update the XR4500 application print token (A65) to use characters that control the green light control command on a XR4500TL remote scoreboard equipped with the traffic light feature.

3.3.2 STOP key

The **STOP** key will update the XR4500 application print token (A65) to use characters that control the red light control command on a XR4500TL remote scoreboard equipped with the traffic light feature.

4 Menus

Password protected menus are available to configure the indicator and/or view information.

4.1 Accessing the menus

Follow these steps to access the menus in the ZM305.

1. With the indicator powered up and in normal operating mode, press and hold **SETUP** ...

Pass is displayed, prompting you to enter the password.

2. Key in the password for the menu you want and press the **ZERO** key ...

The first item in the top level of the menu you accessed is displayed.

3. Use the navigation keys, shown below, to navigate through the menu structure. The symbols in the chart appear on the bottom of the keys.

Press **SELECT**/ ▼ to move down in a menu
 Press **TARE**/ ▲ to move up in a menu, except at the bottom item in a menu, then use **ZERO**/ ←
 Press **PRINT**/ ◀ to move left in a menu
 Press **UNITS**/ ▶ to move right in a menu
 Press **ZERO**/ ← to accept a value or choice and move up in the menu.
 Press **IN/OUT** to abort numeric entries or as an escape from a menu item

4.2 Menu annunciators

The menu structure is made up of menu items, parameters, value entry screens and lists from which you choose one item. To help you know where you are in the menu, the bargraph at the top of the display is on while the indicator is in the menus and will change appearance according to the following rules:

All segments flashing	This means you are in the menu structure but not in any of the following screens.
Center flashing / others solid	This means you are in a parameter prompt screen.
Center flashing / others off	This means you are in a numeric entry screen. Enter a number and press ZERO to accept.
Right flashing / others off	This means you are in a list. Scroll through the choices with the PRINT and UNITS keys and press ZERO to accept.

4.3 Exiting the menus

1. If you are at the bottom item in a menu use **ZERO** to accept a choice or value and move up a level, or use **IN/OUT** to escape and move up one level without accepting the choice or value. From that point, press **TARE** repeatedly until ...

SAVE no is displayed. This means “Do not save changes.”

2. Press **UNITS** to scroll through the choices: **SAVE no**, **SAVEYES** and **CAnCEL**. Press **ZERO** to accept the displayed choice.

If you choose **SAVE no** or **SAVEYES** the indicator exits the menu and returns to normal weighing mode.

OR

If you choose **CAnCEL**, the indicator remains in the menu.

4.4 USER level menus

The USER level menus are available to the user. The other menu levels are for supervisors and technicians only.

The USER level (password 111) contains the User, About, and Audit menus arranged as shown in [Figure 4.1](#).

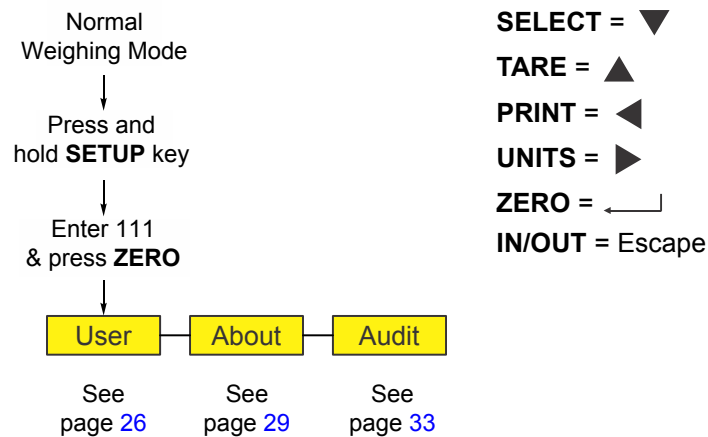

Figure 4.1 USER level (password 111) menus

4.5 User menu

The User menu is shown in [Figure 4.2](#).

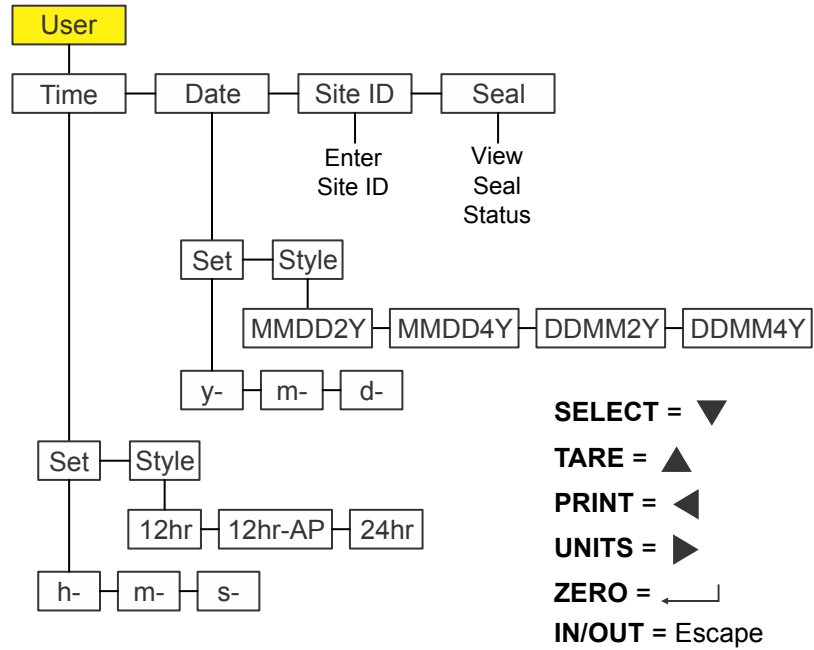

Figure 4.2 User menu

Use this menu to set the time and date, to enter a site ID, and view the physical seal status. Each is explained below:

4.5.1 Time

User ↓ Time



The ↓ and → symbols used in this section stand for direction moved in the menu. So User ↓ Time, shown above, illustrates that you move down from **uSER** to **tiME**. This will help you keep track of where you are in the menu structure.

1. Access the User menu (see [Accessing the menus on page 24](#)) and press **SELECT** ...

tiME is displayed. Use this to set the time and clock style.

2. Press **SELECT** ...

SEt is displayed.

3. Press **SELECT** ...

h- x is displayed, with the **x** flashing. This is a numeric entry screen for the hour value.

4. Key in the hour of the day using military (24 hr) time and press **ZERO** to accept ...

M- x is displayed, with the **x** flashing. This is a numeric entry screen for the minute value.
5. Key in the minute value and press **ZERO** to accept ...

S- x is displayed, with the **x** flashing. This is a numeric entry screen for the second value.
6. Key in the seconds value and press **ZERO** to accept ...

SEt is displayed.
7. Press **UNITS** ...

StYLE is displayed. Use this to set the style of clock for printouts. Choices are **12hr**, **12hr-AP** (AM/PM) and **24hr** (military time).
8. Press **SELECT** ...

12hr is displayed.
9. Press **UNITS** to scroll through the choices. Press **ZERO** to accept the displayed choice ...

StYLE is displayed.
10. Press **TARE** ...

tiME is displayed.

4.5.2 Date

User ↓ Time → Date

1. From **tiME**, press **UNITS** ...

dAtE is displayed.
2. Press **SELECT** ...

SEt is displayed.
3. Press **SELECT** ...

y- x is displayed, with the **x** flashing. This is a numeric entry screen for the year value.
4. Key in the year and press **ZERO** to accept ...

M- x is displayed, with the **x** flashing. This is a numeric entry screen for the month.
5. Key in the month value and press **ZERO** to accept ...

d- x is displayed, with the **x** flashing. This is a numeric entry screen for the day value.
6. Key in the day value and press **ZERO** to accept ...

SEt is displayed.

7. Press **UNITS** ...
StYLE is displayed. Use this to set the style of date for printouts.
Choices are **MMDD2Y**, **MMDD4Y**, **DDMM2Y** and **DDMM4Y**.
8. Press **SELECT** ...
MMDD2Y is displayed.
9. Press **UNITS** to scroll through the choices. Press **ZERO** when your choice is displayed ...
The choice is made and **StYLE** is displayed.
10. Press **TARE** ...
dAtE is displayed.

4.5.3 Site ID

User ↓ Time → Date → Site ID

1. From **dAtE**, press **UNITS** ...
Site id is displayed.
2. Press **SELECT** ...
A numeric entry screen is displayed.
3. Key in a site ID number on the numeric keypad and press **ZERO** to accept ...
Site id is displayed.



The Site ID can be used in transmitted or printing information. ASCII characters 32-126 can be used.

4.5.4 Seal

User ↓ Time → Date → Site ID → Seal

1. From **Site id**, press **UNITS** ...
SEAL is displayed.
2. Press **SELECT** ...
unSEAL or **SEALed** is displayed. This is the status of the physical seal inside the indicator. If the unit is sealed, no changes can be made to the configuration of the indicator.
3. Press **ZERO** to return to the **SEAL** display.
4. To exit the menu, see [Exiting the menus on page 25](#).

4.6 About menu

The About menu is shown in [Figure 4.3](#).

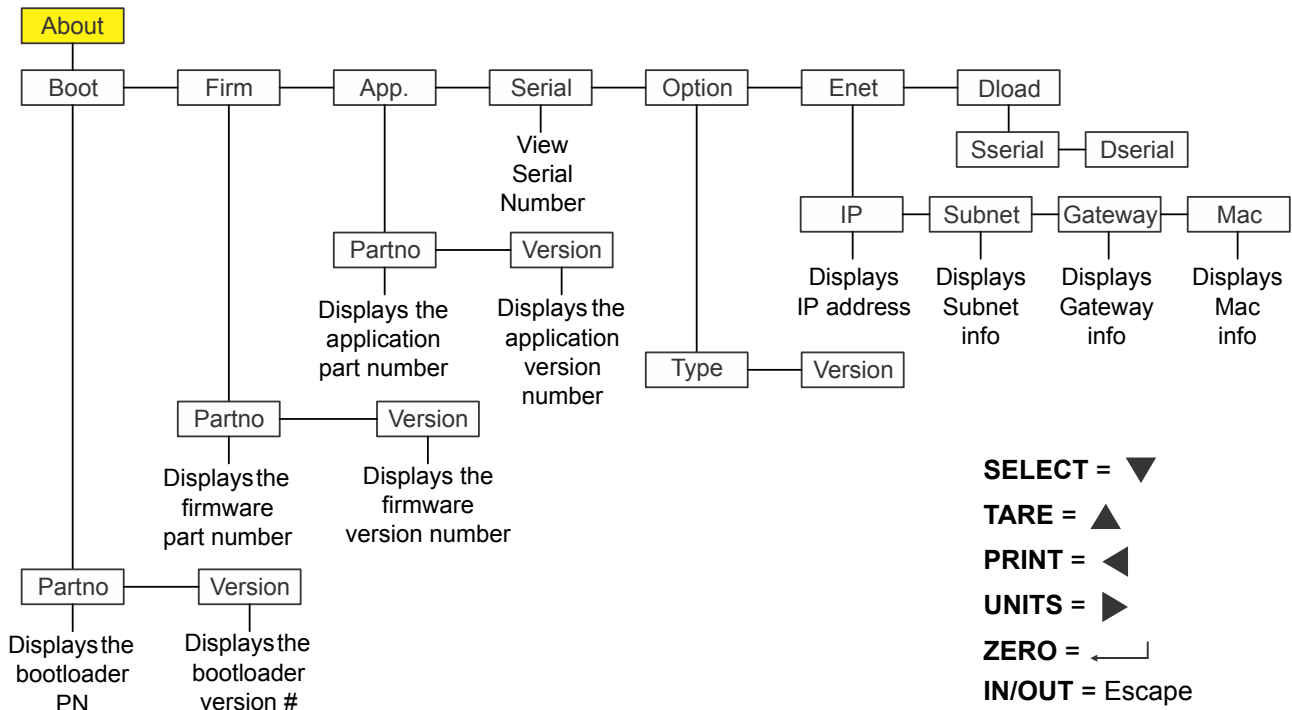

Figure 4.3 About menu

Use this menu to display information about the various items shown in [Figure 4.3](#). Each is explained below:

4.6.1 Boot

About ↓ Boot

1. Access the About menu and press **SELECT** ...
boot is displayed.
2. Press **SELECT** ...
PArtno is displayed
3. Press **SELECT** ...
The 1st half of the bootloader PN is displayed. Press **UNITS** to view the 2nd half.
4. Press **ZERO** to return to the **PArtno** display.
5. Press **UNITS** ...
VErSion is displayed.
6. Press **SELECT** ...
The version number of the bootloader is displayed.

7. Press **ZERO** to return to the **VERsion** display.
8. Press **TARE** to return to the **boot** display.

4.6.2 Firm and App

About ↓ Boot → Firm and App

1. From **boot**, press **UNITS ...**
FirM is displayed. This stands for firmware.
2. Repeat the same pattern of key presses in steps 2 through 7 to view the part number and version for the **FirM**. and **APP** menu items.

4.6.3 Serial

About ↓ Boot → Firm → App → Serial

1. With **APP** displayed, press **UNITS ...**
SEriAL is displayed.
2. Press **SELECT ...**
The first four digits of the indicator serial number are displayed. Press **UNITS** to view the last five digits.
3. Press **TARE** to return to the **SEriAL** display.

4.6.4 Option

About ↓ Boot → Firm → App → Serial → Option

1. From **SEriAL**, press **UNITS ...**
oPtion is displayed.
2. Press **SELECT ...**
VERsion is displayed. This stands for the software version of the currently installed option card. This can be useful service information.
3. To view the version, press **SELECT ...**
The software version number is shown.
4. Press **ZERO ...**
oPtion is displayed.
5. Press **UNITS ...**
tYPE is displayed. This stands for the type of option card installed. The four option cards are: Analog, 802.11g wireless, USB-d, and Current Loop/RS485/RS422.
6. Press **SELECT ...**
The currently installed option card name is displayed.

7. Press **ZERO** ...
tYPE is displayed.
8. Press **TARE** ...
oPtion is displayed.

4.6.5 Enet

About ↓ Boot → Firm → App → Serial → Option → Enet



If the indicator is connected to an ethernet network, the values displayed will be the current assigned addresses.

1. From **oPtion**, press **UNITS** ...
EnEt is displayed. Use this item to view the values for the IP, Subnet, Gateway and MAC addresses.
2. Press **SELECT** ...
iP is displayed. Use this item to view the four part IP address.
3. Press **SELECT** ...
1 XXX is displayed. This is first octet of the IP address
4. Press **ZERO** ...
2 XXX is displayed. This is second octet of the IP address.
5. Press **ZERO** ...
3 XXX is displayed. This is third octet of the IP address.
6. Press **ZERO** ...
4 XXX is displayed. This is fourth octet of the IP address.
7. Press **ZERO** ...
iP is displayed.
8. Press **UNITS** ...
Subnet is displayed.
9. Repeat this sequence of key presses for the **Subnet**, **Gateway** and **MAC** addresses.
10. When finished press **TARE** ...
EnEt is displayed.

4.6.6 Dload

About ↓ Boot → Firm → App → Serial → Option → Enet → Dload

1. From **EnEt**, press **UNITS** ...
dLoAd is displayed. This stands for download. Under **SSEriAL** you can view the serial number of the software application that created the configuration file. Under **dSEriAL** you can view the serial number of the software application that downloaded the configuration file. This is used for security and licensing purposes.
2. Press **SELECT** ...
SSEriAL is displayed.
3. Press **SELECT** ...
The 1st part of the serial number of the creating application of the configuration file is displayed.
4. Press **UNITS** two more times to see the complete serial number.
5. Press **ZERO** ...
SSEriAL is displayed.
6. Press **UNITS** ...
dSEriAL is displayed.
7. Press **SELECT** ...
The 1st part of the serial number of the downloading application of the configuration file was downloaded to, is displayed.
8. Press **UNITS** two more times to see the complete serial number.
9. Press **ZERO** ...
dSEriAL is displayed.
10. Press **TARE** until **About** is displayed.
11. To exit the menu, see [Exiting the menus on page 25](#).

4.7 Audit menu

The Audit menu is shown in [Figure 4.4](#).

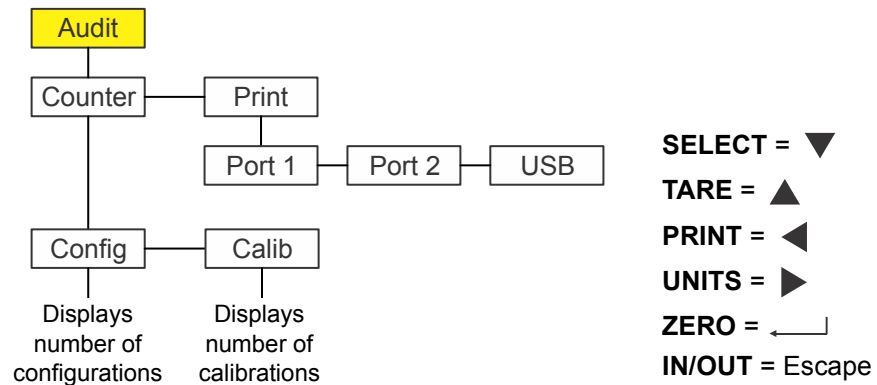

Figure 4.4 Audit menu

Use this menu to display audit counters for configuration and calibration and to print the information. Each is explained below:

4.7.1 Counter

Audit ↓ Counter

1. Access the Audit menu and press **SELECT** ...
countEr is displayed. This has two counters that tell you how many times the indicator has been configured and calibrated.
2. Press **SELECT** ...
conFig is displayed.
3. Press **SELECT** again ...
 A number appears showing how many times the indicator has been configured.
4. Press **ZERO** ...
conFig is displayed.
5. Press **UNITS** ...
cALib is displayed.
6. Press **SELECT** ...
 A number appears showing how many times the indicator has been calibrated.
7. Press **ZERO** ...
cALib is displayed.
8. Press **TARE** ...
countEr is displayed.

4.7.2 Print

Audit ↓ Counter → Print

1. From **countEr**, press **UNITS** ...
Print is displayed.
2. Press **SELECT** ...
Port1 is displayed. This is the first of three choices: **Port 1**, **Port 2** or **uSb**. Use these to select which port to print the audit report through.
3. Press **UNITS** to scroll through the choices and press **ZERO** when your choice is displayed ...
The audit log is printed through the chosen port and **Print** is displayed.
4. This completes the Audit menu. To exit the menu, see [Exiting the menus on page 25](#).

5 Communications

The ZM305 can communicate through these ports:

- Serial
- Ethernet
- USB
- Wireless 802.11g

5.1 Default print formats

Below are examples of the default formats that are available:

Print format #1 (GTN)

```

Gross  272.04 lb
Tare   95.88 lb
Net    176.16 lb

```

Print format #28 (Inbound ticket)

```

In Date 2015-03-25
In Time 10:50:45
      ID   38577
In Weight 14300 lb

```

Print format #27 (Outbound ticket)

```

In Date 2015-03-25
In Time 10:50:45
Out Date 2015-03-25
Out Time 10:56:04
      ID   38577
Transaction 51

Gross   51040 lb
Tare    14300 lb
Net     36740 lb

```

Print format #36 (Fleet ticket)

```
~~~~~  
Date 2015-03-25  
Time 10:51:24  
Fleet ID 759111  
Transaction 192  
  
Gross 69080 lb  
Tare 14100 lb PT  
Net 54980 lb  
~~~~~
```

5.1.1 Report Printout Samples

INBOUND Report

```
~~~~~  
Inbound Vehicle Report  
10:36:41 03-25-2015  
  
ID Time Date Weight  
-----  
966558 20:17 3-9-2015 49300 lb  
561152 22:41 3-11-2015 6800 lb  
443216 13:05 3-18-2015 59000 lb  
606912 5:53 3-18-2015 11620 lb  
394736 1:05 3-18-2015 13380 lb  
  
End of Inbound Report  
~~~~~
```

OUTBOUND Report

```
~~~~~  
Outbound Vehicle Report  
10:39:32 03-25-2015  
  
ID # Trans Total Net Wt  
-----  
674758 2 130400 lb  
806039 2 99200 lb  
961564 6 250100 lb  
735023 5 317900 lb  
495520 10 361200 lb  
  
End of Outbound Report  
~~~~~
```

FLEET Report

Fleet Vehicle Report					
10:43:40 03-25-2015					
Fleet ID	Tare Wt	#	Trans	Total	Net Wt











759109	20500 lb		14	1148000	lb
8262677	12280 lb		32	1571840	lb
8262686	11880 lb		41	1948320	lb
8262691	11940 lb		54	2579040	lb
8262671	11880 lb		56	2661120	lb

End of Fleet Report

6 Error messages







6.1 General messages

The following error messages may be displayed during use of the indicator:

Message	Display
Overload	
Can't fit on display or load cell not properly connected	
Underload	
Can't	
Entry not in valid range	
Password entry failed	
Remote display not receiving data from the master indicator	
Indicator did not reach a stable zero weight within time window set for automated weighing process.	  
Indicates the battery is enabled and TMOU value is set but the indicator is not operating with the proper battery shutoff circuitry	

6.2 Truck scale database CSV file import/export messages

The following error messages may be displayed during use of the indicator:

Message	Display
Failed to get CSV file handle	
Failed to allocate memory for CSV file	
First line of CSV file is invalid	
Failed to read CSV file, size didn't match	
StrRowData too big	
Field count mismatch	
CSV Import field does not exist	

7 Supervisor menu

This menu, [Figure 7.1](#), allows a supervisor to change those functions of the Truck Inbound/Outbound application that are configurable. Access the supervisor menu using the password 1793. Refer to [Accessing the menus on page 24](#) for instructions.

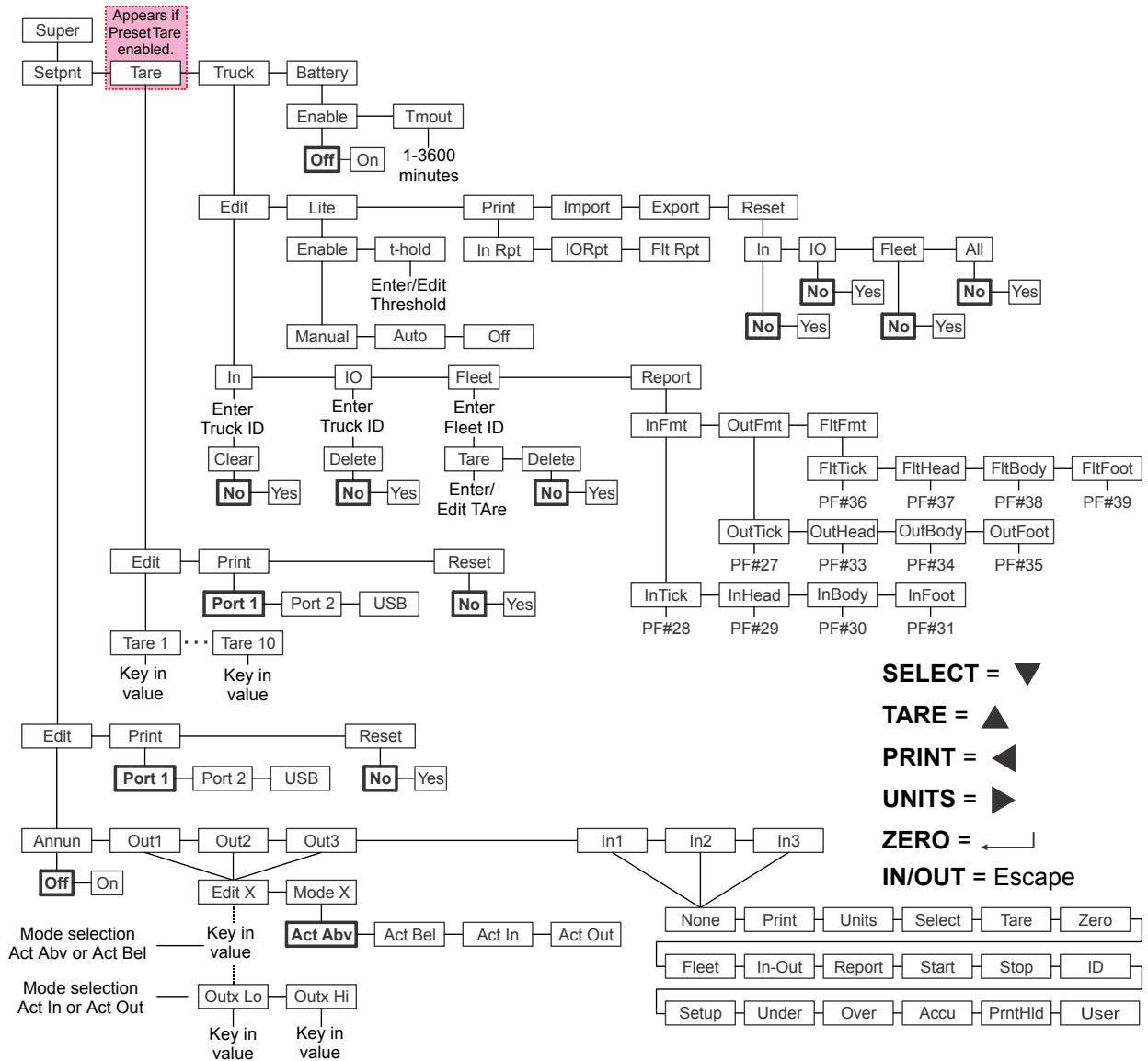

Figure 7.1 Supervisor menu for the Inbound-Outbound application



Wherever there is an option to print information, the information will print out of Port 1, Port 2 or to USB, whichever is configured.



The menus are always explained in a sequential manner to cover all information in a logical fashion. You will probably never access all the menu items in this manner. You can navigate to the area of the menu that needs to be changed by using the navigation key chart shown with the menu.

Follow these steps to set the items in the Supervisor menu.

7.1 Setpoint

Super↓ Setpoint



The ↓ and → symbols used in this section stand for direction moved in the menu. So Super ↓ Setpoint, shown above, illustrates that you move down from **SuPEr** to **SEtPnt**. This will help you keep track of where you are in the menu structure.



If you are using a battery operated indicator with any application, setpoint output #3 can be configured for shutting down the battery for power saving. See the Service manual for information on setting up setpoint outputs and optional power saving circuitry you can create to shutdown power from a battery.



A setpoint value can be entered ranging from +/- scale capacity. See [Entering a negative number on page 14](#) for the negative numeric entry process.

See the Service manual for information on enabling the setpoint outputs. Setpoints that are not used should be disabled.

1. Access the Supervisor menu. Refer to [Accessing the menus on page 24](#) for instructions. From **SuPEr**, press **SELECT** ...

SEtPnt is displayed. Use this to:

- set the mode of setpoint operation
- set the function of the setpoint annunciators
- enter up to three setpoint values
- select function for up to three inputs
- print the setpoint settings
- reset all setpoint settings to factory defaults.

Annunciators

Setpoint ↓ Edit ↓ Annun

2. Press **SELECT** ...

Edit is displayed.

3. Press **SELECT** ...

Annun is displayed.

This stands for annunciators, referring to the *SP1*, *SP2* and *SP3* setpoint annunciators. By default (**oFF**) these annunciators are ON when the selected mode of the setpoint is active or OFF when the selected mode of the setpoint is not active. If you select **on**, the annunciators work in the opposite fashion--OFF when the selected mode is active or ON when the selected mode is not active.

4. Press **SELECT** ...
The current setting is displayed (**oFF** or **on**).
5. Press **UNITS** to toggle between the choices and when your choice is displayed, press **ZERO** to accept ...
Annun is displayed.

Outputs

Setpoint ↓ Edit ↓ Annun → Out

6. Press **UNITS** ...
out1 is displayed. This is the weight value for setpoint 1. You can access **out2** or **out3** by pressing the **UNITS** key. The following instructions apply to any of these three outputs.
7. Press **SELECT** ...
Edit X is displayed. **X** being the number of output.
8. Press **UNITS** ...
ModE X is displayed. This menu item sets the function of the output. Mode selection must be made before entering the Out value.
9. Press **SELECT** ...
The current Mode setting for the selected Output is displayed. The Mode settings are listed below:

Act AbV (default)	The output is active when the weight is above the set value
Act bEL	The output is active when the weight is below the set value
Act in	The output is active when the weight is inside of the low and high set values
Act out	The output is active when the weight is outside of the low and high set values
10. Press **UNITS** or **PRINT** to scroll through the choices shown above and then press **ZERO** to accept the displayed Mode ...
ModE X is displayed.
11. Press **UNITS** ...
Edit X is displayed. Set the value or values for the output under this menu item.
12. Press **SELECT** ...
If you selected Mode **Act AbV** or **Act bEL**, a value entry screen is displayed. Go to step 13.

If you selected Mode **Act in** or **Act out**, **outX Lo** is displayed. This is one of two value entry screens under **Edit X**. Go to step 14.

13. Key in the value you want the output to activate above or below and press **ZERO** to accept the value.
Edit X is displayed. Go to step 18.
14. Key in a value for **outX Lo** and press **ZERO** to accept ...
outX Lo is displayed.
15. Press **UNITS** ...
outX Hi is displayed.
16. Key in a value for **outX Hi** and press **ZERO** to accept ...
outX Hi is displayed.
17. Press the **TARE** key ...
Edit X is displayed.
18. Press the **TARE** key ...
OutX is displayed.
19. Repeat steps 6 through 17 for **out2** and **out3**.

Inputs

Setpoint ↓ Edit ↓ Annun → Out → In

20. Press **UNITS** when finished ...
in1 is displayed. This stands for input 1. Use this to assign a function to input 1 when an external switch is tripped. Default choice is **none**. The choices are listed in [Figure 7.1](#).



Inputs are enabled (ON) in a separate password protected menu. Some input choices will not apply in the application that is active.

21. From **in1**, press **SELECT** ...
The current choice is displayed.
22. Press **UNITS** to scroll through the choices and when your choice is displayed, press **ZERO** to accept ...
in1 is displayed.
23. Press **UNITS** ...
in2 is displayed.
24. Repeat steps 21 through 23 for **in2** and **in3**.
25. Press **TARE** when finished ...
Edit is displayed.

Print

Setpoint ↓ Edit → Print

26. Press **UNITS** ...

Print is displayed. Use this to print the settings under **SEtPnt**.

27. Press **SELECT** ...

Port 1 is displayed.

28. Press **IN/OUT** to abort the print process or press **UNITS** to scroll to the desired port and press **ZERO** to print the information ...

Print is displayed after either action.

Reset

Setpoint ↓ Edit → Print → Reset

29. Press **UNITS** ...

rESEt is displayed. Use this to reset the settings under **Edit** to factory defaults.

30. Press **SELECT** ...

no is displayed.

31. Press **ZERO** to abort the reset or press **UNITS** ...

YES is displayed.

32. Press **ZERO** to reset the settings to factory defaults ...

rESEt is displayed.

33. Press **TARE** ...

SEtPnt is displayed.

7.2 Tare

Super ↓ Setpoint → Tare

If Preset Tare is not enabled in a separate password protected menu, skip to step 7. If it is enabled continue to the next step.

1. Press **UNITS** ...

tArE is displayed.

Use this to:

- set values for up to 10 preset tares
- print the values of the preset tares
- reset all preset tares to factory defaults of 0

The following steps describe the procedures.

Tare Register 1-10

Tare ↓ Edit ↓ Tare 1-10

2. Press **SELECT** ...
Edit is displayed.
3. Press **SELECT** ...
tArE 1 is displayed. This is the first of the 10 preset tare values you can set.
4. Press **SELECT** ...
The current value is displayed with a flashing right digit.



If the active unit of measure is lb-oz then tare weights must be entered in the oz equivalent. To enter 2 lb 4.5 oz you would need to enter 36.5 oz (2 lb = 32 oz plus the 4.5)

5. Press **ZERO** to accept the displayed value or key in a new value and press **ZERO** to accept ...
tArE 1 is displayed.
6. Press **UNITS** ...
tArE 2 is displayed.
7. Repeat steps 4 through 6 for *tArE 2* through *tArE 10*. Press **TARE** when finished ...
Edit is displayed.

Printing

Tare ↓ Edit → Print

8. Press **UNITS** ...
Print is displayed. Use this to print the preset tare values.
9. Press **SELECT** ...
Port 1 is displayed.
10. Press **IN/OUT** to abort the print process or press **UNITS** to scroll to the desired port and press **ZERO** to print the information ...
Print is displayed after either action.

Reset

Tare ↓ Edit → Print → Reset

11. Press **UNITS** ...
rESEt is displayed. Use this to reset the all the preset tares to the factory default of 0.

12. Press **SELECT** ...
no is displayed.
13. Press **ZERO** to abort the reset or press **UNITS** ...
YES is displayed.
14. Press **ZERO** to reset the settings to factory defaults ...
rESEt is displayed.
15. Press **TARE** ...
tArE is displayed.

7.3 Truck

Super ↓ Setpoint → Tare → Truck

1. Press **UNITS** ...
truck is displayed. Use this menu item to create, delete, print or reset Truck records, re-assign the default print formats for various Truck reports, and Import or Export Truck records.

Edit

Truck ↓ Edit

2. Press **SELECT** ...
Edit is displayed. The *Edit* menu lets you clear unnecessary inbound records, delete individual outbound records, create new or edit existing Fleet truck tare weights or delete individual Fleet truck records.

in, io, FLEEt and rEPort

3. Press **SELECT** ...
in is displayed. The choices on this menu level are *in, io, FLEEt* and *rEPort*.

<i>in</i>	Use this to clear an existing Inbound transaction that has not been closed by an Outbound transaction.
<i>io</i>	Use this to delete a Truck I/O record.
<i>FLEEt</i>	Use this to create, edit or delete a Fleet ID record.
<i>REPORT</i>	Use this to print the same reports available from the REPORT key.

4. Press the **UNITS** key to scroll thru the choices. Press **SELECT** when the desired choice is displayed.
 - If you select *in* go to step 5.
 - If you select *io* go to step 10.
 - If you select *FLEEt* go to step 15.
 - If you select *rEPort* go to step 22

Clear Inbound records

5. With *in* displayed, press **SELECT** ...
 - A value entry screen is displayed.
6. Key in the Truck ID and press the **ZERO** key ...
 - cLEAR** is displayed.
7. Press **SELECT** ...
 - no** is displayed.
8. Press **UNITS** to toggle between **YES** and **no**. Press **ZERO** when **YES** is displayed to clear the Inbound record ...
 - bUSY** is briefly displayed and then *in* is displayed.
9. Repeat from step 5 for any other inbound records you want to remove.

Delete Truck I/O records

10. With *io* displayed press **SELECT** ...
 - A value entry screen is displayed.
11. Key in the Truck ID and press the **ZERO** key ...
 - dELEtE** is displayed.
12. Press **SELECT** ...
 - no** is displayed.
13. Press **UNITS** to toggle between **YES** and **no**. Press **ZERO** when **YES** is displayed to delete the Outbound record. This will delete all transaction totals for the selected Truck ID ...
 - bUSY** is briefly displayed and then *io* is displayed.
14. Repeat from step 10 for any other outbound records you want to delete.

Edit Fleet records

15. With *FLEEt* displayed press **SELECT** ...
 - A value entry screen is displayed.

16. Key in the Fleet Truck ID and press **ZERO** ...
If this is an existing ID, **FLEEt** is briefly displayed then **tArE**. Go to step 17.
If this is a new ID, **not Fnd** (not found) is briefly displayed followed by **Adding**, followed by **tArE**.
17. With **tArE** displayed you can either edit the Fleet Tare weight or go to step 19 to delete the Fleet ID. To edit a Fleet Tare weight press **SELECT** ...

Edit Fleet Tare Weight

The next procedure depends on if this is a new or existing Fleet ID and whether an empty Fleet truck is on the scale to establish the tare weight. If there is an empty Fleet truck on the scale (or any weight above the GZB) the live weight will be displayed. Press **ZERO** to save the live weight.



If the Tare value is not greater than the Gross Zero Band, the ID will not be saved.

New Fleet Truck ID

If the weight on the scale is below the Gross Zero Band (GZB) then **0** is displayed. Use numeric entry to manually enter the Fleet truck tare weight.

Otherwise the Saved live weight is displayed. Press **ZERO** to store this value or use numeric entry to manually enter the Fleet truck tare value.

Existing Fleet Truck ID

If the weight on the scale is below the GZB the **PT** annunciator is illuminated and the stored Fleet tare weight is displayed. Use numeric entry to change or press **ZERO** to continue to use this as the Fleet truck tare value.

Otherwise the Saved live weight is displayed. Press **ZERO** to store the live weight or use numeric entry to manually enter the Fleet truck tare value. After pressing **ZERO** to save the value, **tArE** is displayed.

18. To add more Fleet ID's press the **TARE** key to return to step 15 or continue to press **TARE** to exit back to normal operation.

Delete Fleet ID

19. Press **UNITS** ...
dELEtE is displayed.
20. Press **SELECT** ...
no is displayed. This is your option not to delete the Fleet ID.

21. Press **UNITS** to toggle between **YES** and **no**. Press **ZERO** when your choice is displayed ...

If you choose **no**, the ID is not deleted and the display shows **dELeEtE**.

If you choose **YES**, **bUSY** is briefly displayed, the ID is deleted and **FLEEt** is displayed. To delete more Fleet IDs return to step 15 or continue to press **TARE** to exit back to normal operation.

Print Truck Reports

22. From **FLEEt** press **UNITS** ...

rEPort is displayed. This menu item lets you assign a print format number to the various print tickets and reports. The choices are inbound **inFMt**, outbound **outFMt**, and fleet **FLtFMt**. Each one has a separate print format assigned for the Ticket Transaction, the Header, the Body and the Footer.

Under **inFMt** are these items:

inticK This defines which print format is used during the Inbound ticket transaction.

inhEAd This defines which print format is used for the header or top of the Inbound report.

inbodY This defines which print format is used for the body of the Inbound report

inFoot This defines which print format is used for the footer or bottom of each Inbound report.

Under **outFMt** are the same items except the prefix is changed to **out**:

outticK, outhEAd, outbodY, outFoot

Under **FLtFMt** are the same items except the prefix is changed to **FLt**:

FLtticK, FLthEAd, FLtbodY, FLtFoot

23. Press **SELECT** ...

Report Print Formats

For example, the Ticket transaction might print the Truck ID, the time/date, and associated weight values for the type of transaction.

For example, the Header might print the scale owner company name, address and time/date of the report and appropriate labels to align with the information contained in the Body of the report.

The Body would print the Truck ID and associated weights and times (Inbound only). The Body print format performs automatic “loop” printing of the data contained in the print format. The “loop” is controlled by the Truck In, Truck Out and Fleet ID’s print tokens and will continue to repeat the print format for all ID’s that are stored in their respective areas of the database.

For example, the Footer might only print “End of xxxxx Report” or just send a form feed character for proper paper advance upon completion.

Report Printing Structure

When a report is printed, all 3 associated print formats, Header, Body and Footer, are automatically sent to the assigned or binded port. Examples of the default print formats for Tickets and Reports are shown on page 35. Proper editing of these print formats using the internal Editor or the PC software application tool may be necessary for specific application requirements.

See the Supervisor menu in [Figure 7.1](#) to see the default print formats assigned to each item and how to navigate to any item you wish to change.

Editing of a print format requires access to a password protected menu and will not be covered in this manual.

Default Report Print Format Numbers

Report	Ticket	Header	Body	Footer
Inbound	28	29	30	31
Outbound	27	33	34	35
Fleet	36	37	38	39

24. From **rEPort**, press **TARE** ...

Edit is displayed.

Lite menu

Truck ↓ Edit → Lite

25. From **Edit**, press **UNITS** ...

LitE is displayed. This item allows configuration of set point 1 & 2 to control an external traffic light or device based on GTN operations.



Outputs #1 and #2 must be enabled for the set point controls to function properly.

26. Press **SELECT** ...

EnAbLE is displayed. Choose from these three options under enable:

- | | |
|---------------|---|
| Manual | BOTH the set point outputs #1 & #2 and the serial commands for the XR4500TL are controlled by the START/STOP keys. |
| Auto | <p>BOTH the set point outputs #1 & #2 and the serial commands for the XR4500TL are controlled as follows:</p> <ul style="list-style-type: none"> • Set point #1 is active for green light when scale is considered at ZERO while inside gross zero band, or when the PRINT key has been processed. (Scale Configuration Parameter) • Set point #2 is active for red light when gross weight is above the threshold value. • Set point #3 is available for standard configuration (cutoff) as long as the battery saver feature is not used. |
| OFF | Set point controls are controlled by standard configuration settings (cutoffs) and ONLY the XR4500TL works with the START/STOP keys. |

27. From **EnAbLE** press the **UNITS** key ...

t-HoLd is displayed. This stands for Threshold. Use this to configure the weight value that must be exceeded for the light control to activate the red light (set point #2) when configured for the AUTO mode of operation.



START key

The **START** key will update the XR4500 application print token (A65) to use characters that control the green light control command on a XR4500TL remote scoreboard equipped with the traffic light feature. The characters are included in the default print format that is assigned to Broadcast to the remote scoreboard display.

STOP key

The **STOP** key will update the XR4500 application print token (A65) to use characters that control the red light control command on a XR4500TL remote scoreboard equipped with the traffic light feature. The characters “@ & <CR>” are included in the default print format that is assigned to Broadcast to the remote scoreboard display.

Print menu

Truck ↓ Edit → Lite → Print

28. From **LitE**, press **UNITS** ...

Print is displayed. This menu item allows you to print the transaction reports. These selections are from the **REPORT** key but are also included in the Supervisor menu if the **REPORT** key is disabled.

in rPt Prints the report of all the Trucks that have recorded an Inbound transaction but have yet to complete the Outbound transaction. Individual or all Inbound records can be cleared using the **rESEt** menu item explained on page 54.

out rPt Prints the report of all the Truck ID's and associated totals that have completed an Outbound transaction. Individual or all Outbound records can be cleared using the **rESEt** menu item explained on page 54.

FLt rPt Prints the report of all the Fleet Truck ID's and tare weights and associated totals. Individual or all Fleet records can be cleared using the **rESEt** menu item explained on page 54.

29. To exit the reports level, press **TARE** ...

Print is displayed.

Import

Truck ↓ Edit → Lite → Print → Import

The Import menu allows for transfer of a Truck Scale database file from a USB memory device when inserted into the USB port of the indicator.

For a typical truck scale operation the only reasons to import a database would be to:

- Add Fleet Truck ID's and Tare weight records into the scale without having to use the EDIT menu
- Edit existing totals to correct errors or missing weighments such as failure to record an Outbound transaction or using an incorrect Truck ID.

To successfully Import the truck scale database into the indicator the file must be in the proper CSV (comma separated value) format. To insure that the CSV file format is acceptable, the following procedure is recommended. Perform an In/Out transaction, and if the operation uses Fleet trucks, add at least one Fleet Truck ID / Tare weight in the EDIT menu. Then EXPORT the database file to the USB thumbdrive. The database file will show the required data fields that must be maintained.

Open the file using Excel and copy and paste a row containing the entered Truck values into the number of rows necessary. Edit the pasted rows with the required data and be sure to put 0's into unused columns.

Save the file on the thumbdrive and IMPORT back to the indicator to update the Truck database.



The USB thumbdrive must be installed before accessing the Import or Export menus.

30. From **Print**, press **UNITS ...**

iMPort is displayed.

Use the import menu to import the Truck Scale database file from a USB thumbdrive using the USB port of the indicator.



The database can contain up to 1000 separate truck records.

Importing a database file will overwrite all existing Truck records stored in the indicator. This database file includes all Truck In/Out and Fleet ID's, open Inbound transactions with time, date and weight, and Gross, Net, Tare, and Transaction Count totals for completed In/Out and Fleet transactions.

31. With **iMPort** displayed, press **SELECT ...**

buSY and **donE** are briefly displayed as the database file is imported. **iMPort** will be displayed when finished.

32. Press the **UNITS** key ...

EXPort is displayed. Use the export menu to export the Truck Scale database file to a USB thumbdrive using the USB port of the indicator.

Export

Truck ↓ Edit → Lite → Print → Import → Export

The Export menu allows for transfer of a CSV (Comma Separated Values) file containing the Truck Scale database to a USB memory device when inserted into the USB port of the indicator.

33. From **EXPort**, press **SELECT ...**

buSY and **donE** are briefly displayed as the database file is exported. **EXPort** is displayed when finished.

34. Press the **UNITS** key ...

rESEt is displayed. The Reset menu lets you delete stored records in the truck database.

Below is a sample of a CSV file structure:

truckId	tareFleet	weight1	weight1date	weight1time	grossTotal	netTotal	tareTotal	transCount	units
111	0	0			300000	200000	100000	10	lb
222	0	0			800000	400000	400000	20	lb
123	12300	0			1500000	1000000	500000	30	lb
456	14550	0			39550	25000	14550	1	lb
1	11240	0			62480	40000	22480	2	lb
5	0	16210	2/3/2014	9:51:39	0	0	0	0	lb

Reset

Truck ↓ Edit → Lite → Print → Import → Export → Reset

35. From **rESET**, press **SELECT ...**
in is displayed.
36. Press **UNITS** or **PRINT** to scroll through the choices: *in*, *io*, **FLEET** or **ALL**.
 With the type of record you want to clear or delete displayed, press **SELECT ...**
no is displayed.
37. Press **UNITS** to display **YES** and then press **ZERO** to clear the record ...
 The display will show **BUSY** and then return to *in*, *out* or **FLEET** depending on which menu item was selected



*Resetting the **IN** records will clear all stored Inbound records that have not yet completed an Outbound transaction.*

*Resetting the **OUT** records will delete all stored Truck I/O ID's and associated Totals.*

*Reset the **FLEET** records will delete all stored Fleet Truck ID's, Tare weights and associated Totals.*

*Deleting **ALL** will delete all the above Truck records from the database.*

38. Repeatedly press the **TARE** key ...
 until **truck** is displayed.

7.4 Battery

Super ↓ Setpoint → Tare → Truck → Battery

1. From **truck**, press **UNITS** ...

bAttErY is displayed. Use this to enable the battery and to set a timeout length (in minutes). If this time expires with no scale or keypad activity, setpoint #3 will change states so the battery will shut off if the proper external circuitry is provided. See the Service manual.

Enable

Battery ↓ Enable



*Only enable the battery and set the **tMout** value if the battery has the proper external shutoff circuitry. If battery use is enabled, setpoint output 3 cannot be used for setpoints in any application. It is used as a shutoff signal.*

2. Press **SELECT** ...

EnAbLE is displayed. Choices are **OFF** and **on**. Choose **OFF** to disable battery usage. Choose **on** to enable battery usage.

3. Press **UNITS** to toggle between the choices and when your choice is displayed, press **ZERO** to accept ...

EnAbLE is displayed.

Timeout

Battery ↓ Enable → Timeout

4. Press **UNITS** ...

tMout is displayed. This stands for timeout. Use this to set the length of time before inactivity of the scale and keypad cause battery power to be shutoff. Values between 1 and 3600 minutes are valid. **This function only works if the battery has shutoff circuitry.**

5. Press **SELECT** ...

A numeric entry screen appears.

6. Key in a value, in minutes and press **ZERO** to accept ...

tMout is displayed.

7. This completes the Supervisor menu for General Weighing. Repeatedly press **TARE** until the indicator returns to normal weighing mode.

The current weight value is displayed.

Avery Weigh-Tronix



Avery Weigh-Tronix USA

1000 Armstrong Dr.

Fairmont MN 56031 USA

Tel:507-238-4461

Fax:507-238-4195

Email: usinfo@awtxglobal.com

www.averyweigh-tronix.com

Avery Weigh-Tronix UK

Foundry Lane,

Smethwick, West Midlands,

England B66 2LP

Tel:+44 (0) 8453 66 77 88

Fax:+44 (0)121 224 8183

Email: info@awtxglobal.com

www.averyweigh-tronix.com