



ZM303
IP69K Stainless Steel Enclosure
TN Display
IP69K

ZM303
Panel Mount Enclosure
IBN Display

ZM301
Aluminium Enclosure
IBN Display

Indicators to measure and control your daily operations.

Technical Specification



DESCRIPTION

Highly adaptable and available with a choice of display technologies and enclosures, these high performance, multi-function indicators give you the flexibility required to suit different applications. Suitable for the office and high pressure and heavy washdown environments, the ZM300 series will analyse, store, display and transmit data across a range of applications.

SPECIFICATIONS

GENERAL

Operating Applications	General weighing, accumulation, check weighing, counting, peak measurement, batching and remote display
Unit of Measure	Six, configurable (Pounds, Kilograms, Ounce, Gram, Pound/Ounce, Custom)
Capacity Selections	9,999,999 with decimal located zero to five places
Incremental Selections	Multiples and sub-multiples of 1, 2, 5
Programmable Selections	Zero range, motion detection, automatic zero tracking, five point linearisation
Time and Date	Battery backed up time/date/year (12 hr or 24 hour format)
Calibration	Two to five points stored
Analog to Digital Measurement Rate	80 Hz
Internal Resolution	53,687,100 counts per mV/V per second
Digital Filtering	Harmoniser filtering with adaptable constant and threshold
Self Diagnostics	Display, keys, inputs, outputs, serial port

USER INTERFACE

Keypad	ZM301: 6 key chemical resistant keypad with metal domed tactile feedback ZM303: 24 key chemical resistant keypad with metal domed tactile feedback
Operational Keys	ZM301: Zero, Print, Units, Tare, Select, F1 ZM303: Zero, Print, Units, Tare, Select, Sample, Target, ID, Start, Stop, 0-9, Decimal, Clear, F1, Setup
Status Annunciators	Center of Zero, Motion, Gross, Net, Tare, Count, Print, Battery status, Set point 1,2,3, Over/Under/Accept bar graph or fill bar graph, LB, KG, Gram, Oz, Preset Tare, Quantity, (Custom unit of measure – Ton, Tory Ounce, Tonne, Feet/Meters, etc), Active Ethernet connection.
Display	<i>IBN illuminated:</i> 7 digit, nine segment display, green on black background for indoor use <i>TN backlit (ZM303 only):</i> 7 digit nine segment display, black on green background ideal for outdoor/indoor use 0.8" (20 mm) high digits Annunciators for status and mode identification Sortbar/Checkweigher segments
Display Rate	Selectable (1, 2, 5, 10, 20) times per second

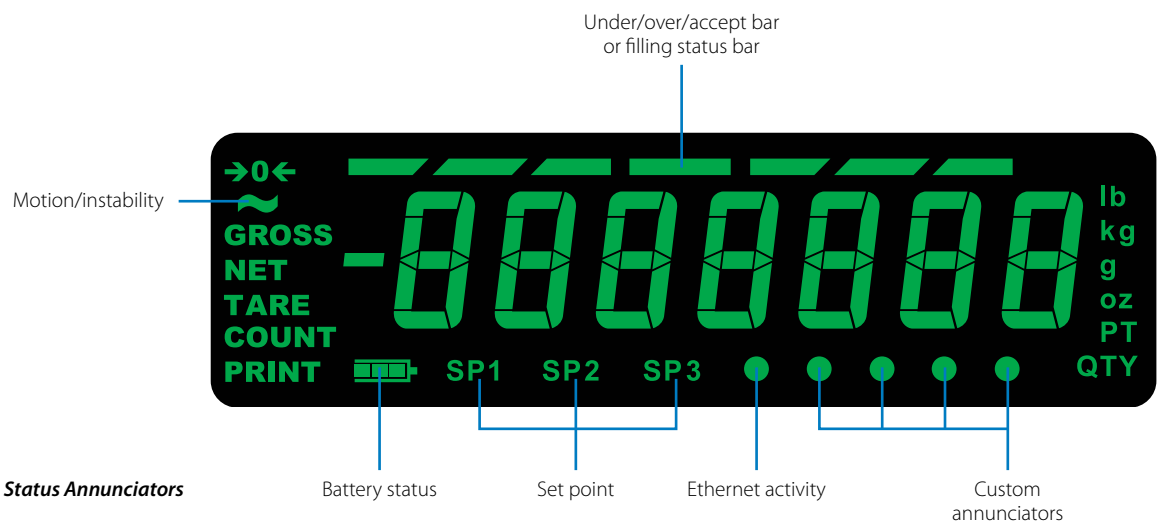

IBN display – Ideal for indoor use



TN display – Ideal for outdoor/indoor use (ZM303 only)



ZM301 keypad - 6 keys



ZM303 keypad - 24 keys

PHYSICAL

Enclosures	<p><i>Stainless steel:</i> 304 brushed stainless steel (IP69K certified) with GORE® Vent ventilation and tilt stand with provisions for desk, wall and column mounting</p> <p><i>Aluminium:</i> Aluminium black powder painted IP20 with rubber feet</p> <p><i>Panel mount:</i> Stainless steel panel mount IP66</p>
Operating Temperature	<p>Compliance with legal for trade requirements</p> <p>-4° F to 140° F / -20° C to 60° C (industrial)</p> <p>10 to 90% humidity</p>
Shipping Weight	<p>Stainless steel: 8.09 lb (4.05 kg)</p> <p>Aluminium: 4.75 lb (2.37 kg)</p> <p>Panel mount: 6.53 lb (3.27 kg)</p>
Dimensions (L X W X H)	<p><i>Stainless steel:</i> 9.6" x 5" x 8.8" (243 mm x 127 mm x 223 mm)</p> <p><i>Aluminium:</i> 8" x 3.2" x 6.3" (203 mm x 81 mm x 160 mm)</p> <p><i>Panel mount:</i> 8.7" x 3.4" x 6.9" (221 mm x 86 mm x 175 mm)</p>

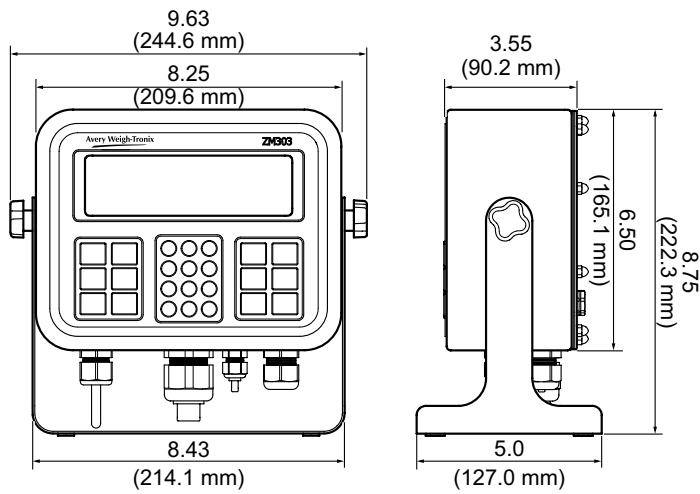

Stainless Steel **IP69K**

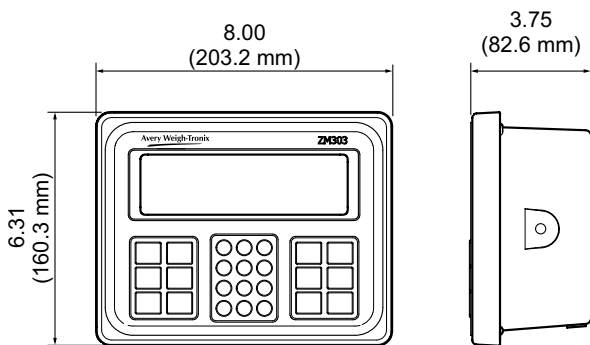

Aluminium

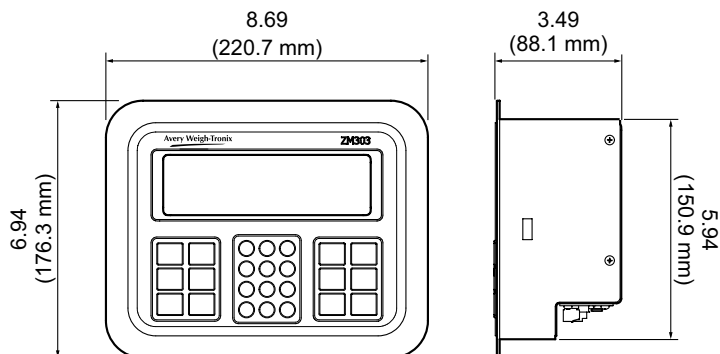

Panel Mount

INPUT/OUTPUT

Remote Inputs	Three logic level inputs for Zero, Print, Tare, Units or F1
Standard Outputs	Three set point outputs, open collector design
Serial Ports	Two serial ports: - Comm 1 RS232 full duplex - Comm 2 RS232 full duplex Or - Comm 1 RS232 full duplex with handshaking - Comm 2 Not available Programmable serial response to ASCII input SMA protocol, broadcast, enquire
USB Host	Printer Connect USB flash memory
Ethernet	Ethernet IP, FTP, Modbus TCP and DHCP
Optional	Analogue output Current Loop/RS485/RS422 USB Device Internal Wireless 802.11b/g

ELECTRICAL

Power Requirements	<i>Line voltage:</i> 90-264 VAC (110-240 VAC nominal), frequency 50 or 60 Hz, 12 to 36 VDC <i>Power consumption:</i> estimated at 200 mA at 12 VDC for one weight sensor and 250 mA at 12 VDC for six weight sensors.
Excitation	5 VDC, short circuit protected Supports up to six 350 ohm weight sensors 4 or 6 conductors with sense leads Detachable plug connectors
Analog Signal Input Range	-1 mV/V to 5 mV/V
Analog Signal Sensitivity	0.1 μ V/V/divisions minimum 0.5 μ V/V/divisions recommended
Circuitry Protection	RFI, EMI and ESD protection

OPTIONS

PC Card (choose one)	<i>Analogue output card:</i> 0-5 VDC, 0-10 VDC and 4-20 mA <i>Current Loop Card:</i> Current Loop and RS485/RS422 <i>USB device card:</i> Provides USB interface to PC <i>Wireless internal card:</i> 802.11b/g wireless data communications kit with antenna
External Battery Pack	Attachable external battery pack with on/off. Uses four D batteries providing 12 hours operation on a single weight sensor system and 11 hours on a four weight sensor system
ZM-OPTO	Provides setpoint interface
USB Watertight Gland	Rubberised and sealed with 6" lead
Ethernet Watertight Gland	Rubberised and sealed with 6" lead
Stand Kit	For aluminium enclosure models

APPROVALS

Patent	US Patent 672,262
Agencies <i>*pending</i>	NTEP (US) Class III/IIIL 10,000 d (CC# 11-096) OIML (European and UK) Class III 6,000 d (R76/2006-GB1-12.04) Measurement Canada (AM-5841C) Australia (NMI S570) MID R61 South Africa* New Zealand (MCA 2100) India* CE UL/C-UL-US EC IP69K (case)



GSE Scale Systems

A member of Avery Weigh-Tronix
Joseph-von-Fraunhofer-Str.3C
52477 Alsdorf, Germany
info@gse-europe.de
Phone: +49 (0) 2404 91869-0
Fax: +49 (0) 2404 91869-20

Avery Weigh-Tronix

www.averyweigh-tronix.com

Avery Weigh-Tronix is an ITW company



© Avery Weigh-Tronix group of companies 2013. All rights reserved. Avery Weigh-Tronix is a registered trademark of the Avery Weigh-Tronix group of companies. This publication is issued to provide outline information only which, unless agreed by an Avery Weigh-Tronix group company in writing, may not be regarded as a representation relating to the products or services concerned. This publication was correct at the time of going to print however, Avery Weigh-Tronix reserves the right to alter without notice the specification, design, price or conditions of supply of any product or service at any time.

zm300series_spec_en_de_500979.indd (C&D)
V2 AWT35-500979