

Avery Weigh-Tronix

ZK830

COUNTING SCALE CHECKWEIGHER BENCH SCALE

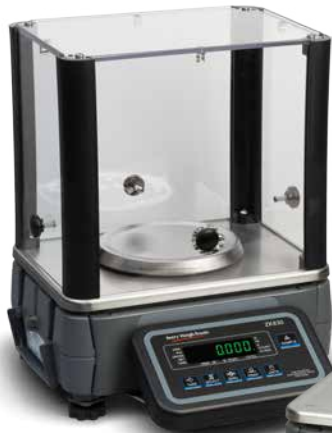

ZK830 9" x 12"
with draft shield



ZK830 12" x 14" with
stack light and keypad



ZK830 9" x 12"
with keypad

High resolution
industrial digital scale

Technical Specification

DESCRIPTION

The ZK830 is a high resolution Quartzell™ digital bench scale that can be set up as a dedicated counting scale, checkweigher or a standalone bench balance.

The unique modular base and indicator combination uses our robust BSQ Quartzell bench base with up to 1 billion internal count resolution and 1100% overload protection. Teamed with the user-friendly, multi-function ZK830 indicator, this scale performs in a wide range of industrial applications and environments.

Counting

With the ability to count a wide range of components, from micro parts weighing less than 10 mg to much heavier items, the ZK830 comes with easy-to-use accurate sampling routines, allowing up to 99.75% sampling accuracy.

The scale has 40 PLU piece weight data storage, a full range of connectivity and the ability to link in a second remote platform.

Checkweighing

Fast, reliable and extremely accurate, the ZK830 is simple to operate with high resolution under, over and accept bands and a PLU target weight data base capable of holding up to 40 target weights with high and low weight limits. The ZK830 hosts full range of connectivity for capturing data along with I/O for running external light stacks or alarms if required.

High Resolution Balance

Designed for accuracy and reliability, this industrial bench scale provides balance accuracy for use in an industrial environment. High resolution mode enables the operator to quickly view an improved resolution reading by a factor of 10, at the press of a key.

COUNTING SPECIFICATIONS

OPERATING APPLICATIONS

Counting Application	Easy-to-use sampling routines including a one key press bulk process to a two key press dribble sampling routine where the sample key is pressed once all sample parts are on the scale (dribble is the default mode) Positive and negative sampling both possible
Check Counting	Ideal when batching product by count items rather than weight
Count Accumulation	Designed to quickly totalize all counted items that have been processed or counted on the scale
40 PLU Data Storage	Stores and recalls piece weight and tare weights within the scale
Second Remote Base	Auto or key activated remote base switching

SUPERVISOR CONTROLLED KEY ADVANCED SETTINGS

Required Sampling Routine	Bulk or dribble sampling (default setting is dribble)
Minimum Sample Size	Limits the sample size that can be entered in the scale
Required Accuracy	Allows supervisor to set the required scale accuracy subject to the environment and components being weighed (99.5% to off)
Minimum Sample Weight	Limits the operator on the minimum sample weight they can use to get an accurate piece weight (turning this function off reduces the probability of achieving the required accuracy)
Data Base Edit	Allows supervisor to store up to 40 known piece weights and tare weights along with upper and lower limits if check counting is activated
Auto Component Latching	Ideal when weighing extremely light components to help stabilize the weight reading after counting
Auto Base Switching	Allows the supervisor to select which base they want to use for sampling when a second base is installed

CHECKWEIGHING SPECIFICATIONS

OPERATING APPLICATIONS

Checkweighing	High resolution target weight checkweighing application, ideal for target weight data retrieval or for improving product line efficiency. Designed for easy setup of target weight with easy-to-read under, over and accept segments to improve throughput to help reduce operator fatigue
----------------------	--

SUPERVISOR CONTROLLED KEY ADVANCED SETTINGS

Target Window Tolerance	Allows supervisor to easily set the accept window by the required + or - weight from the target point
Under and Over Segment	Allows the supervisor to set the three segments for under and the three segments for over independently, by division size
40 PLU Data Storage	Allows regularly used target weight accept band limits to be stored and recalled along with any required stored tares
Accumulation	Designed to totalize gross or net weights
Transaction Counter	Counts the number of transactions the scale has performed

BENCH SCALE SPECIFICATIONS

OPERATING APPLICATIONS

Weigh Only Mode	High resolution weigh only function simplifies user operation. Utilizes standard functions such as gross net, tare weight, unit switching and printing High resolution to a factor of 10 allows the operator with a press of a key to quickly view a higher resolution reading by a factor of 10 (remote keypad is recommended when using this function)
Accumulation	Designed to totalize gross or net weights
40 PLU Data Storage	Allows regularly used tare weights be stored and recalled
Accumulation	Designed to totalize gross or net weights
Transaction Counter	Counts the number of transitions the scale has performed
Percentage Weighing	Allows the scale to display the percentage of weight change from a known set target weight

ZK830 INDICATOR

OPERATING APPLICATIONS

Compatibility	Supplied connected to one BSQ base as standard Max number of bases allowed: two (one local BSQ base and a second BSQ or analog platform) Can link to a second BSQ by utilizing one RS232 port Can also link to an analog remote base (with up to six 360 ohm loadcells) by installing an optional 5 VDC excitation analog base card and remote keypad
Units of Measure	Two independent configurable units of measure (pounds, kilograms, grams, ounces custom)
Construction	High resolution Quartzell mounted inside a robust aluminium die-cast clamshell BSQ base with 1100% overload and shock load protection ZK830 indicator is protected inside a tough ABS indicator housing that is most commonly mounted to the front of the BSQ base. This ZK830 indicator can also be easily removed for wall or deck mounting. Max workable distance for indicator to work away from the base is 50 ft (15m)
Indicator Display	Green on black IBN display ideal for low lit areas. Easy to read seven digit ½" (13mm) high seven segment display. Green under, over and accept segment bar.

Metrology Data	Stored within the ZK830 indicator
Indicator to Base Communications	Local BSQ base connection: one dedicated RS232 connection using a keyed RJ45 connector found on the rear of the ZK830 indicator Second BSQ base: to be wired in through the RS232 communication port (one found on the rear of the ZK830 indicator) (SMA, 115200, eight data bits, none, one stop bit) Second analog base: wired into dedicated second analog base connector. Requires optional 5V ex card fitting along with remote keypad
ZK830 Connection Sockets	ZK830 comes as standard with two serial ports, one Ethernet, three inputs and three outputs Two RS232 serial ports (green connector) One mini USB VCP port: connected in parallel with COM2 or consumes COM2 if used One Ethernet port (local base: client or server. Dual base: server only) One analog port (green connector) only active when optional 5V analog card is fitted One side RJ45 connector dedicated for remote keyboard only One 9V DC power socket to allow the base or indicator to be powered from the DC socket on the rear of the BSQ base or directly from the rear of the ZK830 indicator
Power Options	100V to 240V AC 50/60 Hz switch mode power supply mounted to the rear of the base Base can be powered using either a power jack on the rear of the base or to the rear of the indicator
Battery Power Option	Factory fit NIMH rechargeable battery option to give up to 16 hours of continuous usage Or ZQ remote battery option gives up to 25 hours' continuous usage

MAIN CAPACITIES AND RESOLUTIONS AVAILABLE

Weigh Platter Size	Non Legal for Trade 100,000d	Legal for Trade 10,000d NTEP	Non Legal for Trade 100,000d	Legal for Trade OIML 10,000d
6" dia (156mm)	1 lb x 0.00001 lb	1 lb x 0.0001 lb	500 g x 0.005 g	
6" dia (156mm)	2 lb x 0.00002 lb	2 lb x 0.0002 lb	1000 g x 0.01 g	1000 g x 0.1 g
6" dia (156mm)	5 lb x 0.00005 lb	5 lb x 0.0005 lb	2000 g x 0.02 g	2000 g x 0.2 g
9" x 12" or 12" x 14" (230 x 305 or 305 x 350mm)	10 lb x 0.0001 lb	10 lb x 0.001 lb	5000 g x 0.05 g	5000 g x 0.5 g
9" x 12" or 12" x 14" (230 x 305 or 305 x 350mm)	25 lb x 0.0002 lb	20 lb x 0.002 lb	10 kg x 0.0001 kg	10 kg x 0.001 kg
9" x 12" or 12" x 14" (230 x 305 or 305 x 350mm)	50 lb x 0.0005 lb	50 lb x 0.005 lb	25 kg x 0.0002 kg	25 kg x 0.002 kg
9" x 12" or 12" x 14" (230 x 305 or 305 x 350mm)	70 lb x 0.001 lb	70 lb x 0.01 lb	35 kg x 0.0005 kg	35 kg x 0.005 kg
12" x 14" (305 x 350mm)	100 lb x 0.001 lb	100 lb x 0.01 lb	50 kg x 0.0005 kg	50 kg x 0.005 kg
12" x 14" (305 x 350mm)	175 lb x 0.002 lb	175 lb x 0.02 lb	80 kg x 0.001 kg	80 kg x 0.01 kg

Operating Temperature	41° F to 104° F / +5° C to 40° C (approvals) at 10 to 90% humidity -4° F to 140° F / -20° C to 60° C (industrial) at 10 to 90% humidity
Foot Adjustment	Water resistant anti-slip rubber foot with finger grip locking ring to allow up to 0.75" (19 mm) height adjustment
IP Rating	Designed to meet IP42
Carry Handles	Carry handles allow this scale base to be easily carried around
Options	Ball top for 12" x 14" base Draft shield (up to 10 lb / 5 kg only) Clamp down plate Printers Scanners Remote analog card Wireless card Stack light Indicator wall or desk brackets Underhook (only used on bases up to 10lb / 5kg) 15" or 23" Stainless steel indicator columns

Approvals

NTEP 10,000d
Measurement Canada 10,000d*
OIML 10,000d, EC 10,000d
UL/c-UL-US, CE, RoHs, RCM approved*
*pending



Measurement *
Canada Approved



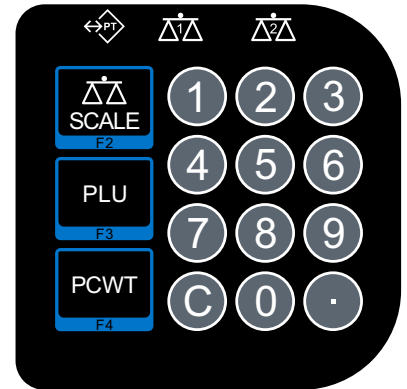
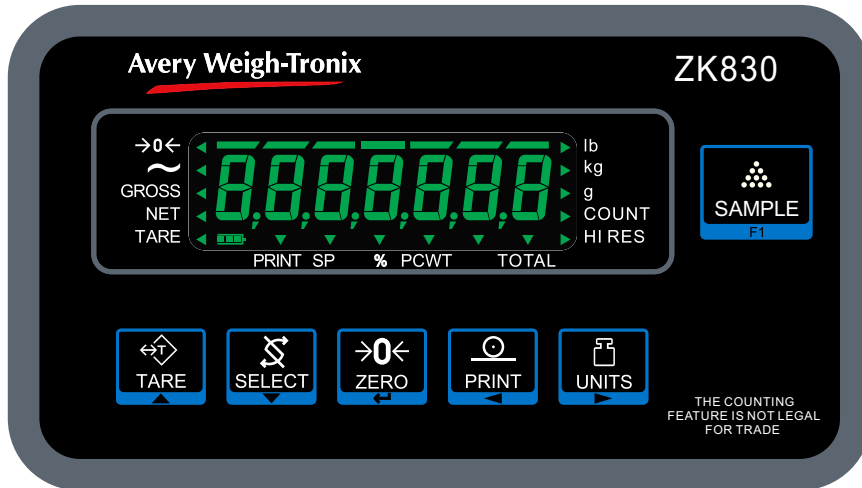

Operator Keys	Six metal domed keys with audible feedback (Sample F1, Tare, Select, Zero, Print, Units)
Remote Keypad (optional)	15 key remote keypad that can easily be attached to any ZK830, giving expanded functionality Required when using a second remote base, when using internal stored PLU database, or entering known piece weights or tare weights Key functions: 0 to 9 numeric keys, cancel, decimal point, scale switching, PLU, piece weight key
Base Size and Capacity	1 lb to 2 lb (500 g to 1 kg) Max 9" x 12" with 6" (156mm) diameter weight platter 2 lb to 10 lb (1 kg to 5 kg) Max 9" x 12" with 6" (156mm) diameter weight platter 10 lb to 70 lb (5 kg to 35 kg) Max 9" x 12" (230mm x 305mm) 10 lb to 70 lb (5 kg to 35 kg) Max 12" x 14" (305mm x 350mm) 70 lb to 175 lb (35 kg to 80 kg) Max 12" x 14" (305mm x 350mm)
Digital Filtering	Three digital Harmonizer™ filters stored within the indicator with adjustable average, constant and threshold filter settings
Time and Date	Battery backed up time/date/year (12 hour or 24 hour format)
Calibration	Up to five points of calibration, stored within the ZK830 indicator
Display Rate	100Hz
Non Legal for Trade Resolution	100,000 divisions center of pan, stable room temperature Up to three range multi interval or multi range can be configured for non legal for trade applications
Legal for Trade Resolution	10,000 divisions class III (single range only)
Readability	Can be set up to display up to 3,500,000 divisions
Internal Resolution	1 billion counts (1,000,000,000 internal counts)
Loadcell Technology	High accuracy digital Quartzzell transducer
Overload Protection	1100% overload protection
Corner Loading	Spring breakaway system is activated at 120% full capacity or 60% corner only load
Recommended Minimum Piece Weight by Base Type (Sample Size of 50)	2 lb (1kg) min piece weight : 0.000004 lb (2 mg) min sample weight: 0.00022 lb (0.1 g) 10 lb (5kg) min piece weight : 0.000022 lb (10 mg) min sample weight: 0.0011 lb (0.5 g) 70 lb (35kg) min piece weight : 0.000154 lb (70 mg) min sample weight: 0.0077 lb (3.5 g) 175 lb (80kg) min piece weight: 0.000352 lb (160 mg) min sample weight: 0.0176 lb (8 g)
Count Accuracy	Fully configurable up to 99.5% subject to environment and component size being sampled
Filter Setting	Controlled within the ZK830 indicator
Creep	0.001% of 100,000 divisions over a 30 minute period or 0.0005% of 200,000 divisions over a five minute timespan
Minimum Recommended Non Verifiable Division Size	0.000001 lb (0.0005 g) for the 2 lb (1 kg) BSQ base 0.000005 lb (0.002 g) for the 10 lb (5 kg) BSQ base 0.00002 lb (0.01 g) for the 70 lb (35 kg) BSQ base 0.00005 lb (0.02 g) for the 175 lb (80 kg) BSQ base
Division Size (Class III)	0.0005 lb (0.1 g) for the 2 lb (1 kg) BSQ base (10,000d approved) 0.00116 lb (0.5 g) for the 10 lb (5 kg) BSQ base (10,000d approved) 0.002 lb (1 g) for the 70 lb (35 kg) BSQ base (10,000d approved) 0.005 lb (2 g) for the 175 lb (80 kg) BSQ base (10,000d approved)

DIMENSIONS 12 x 14

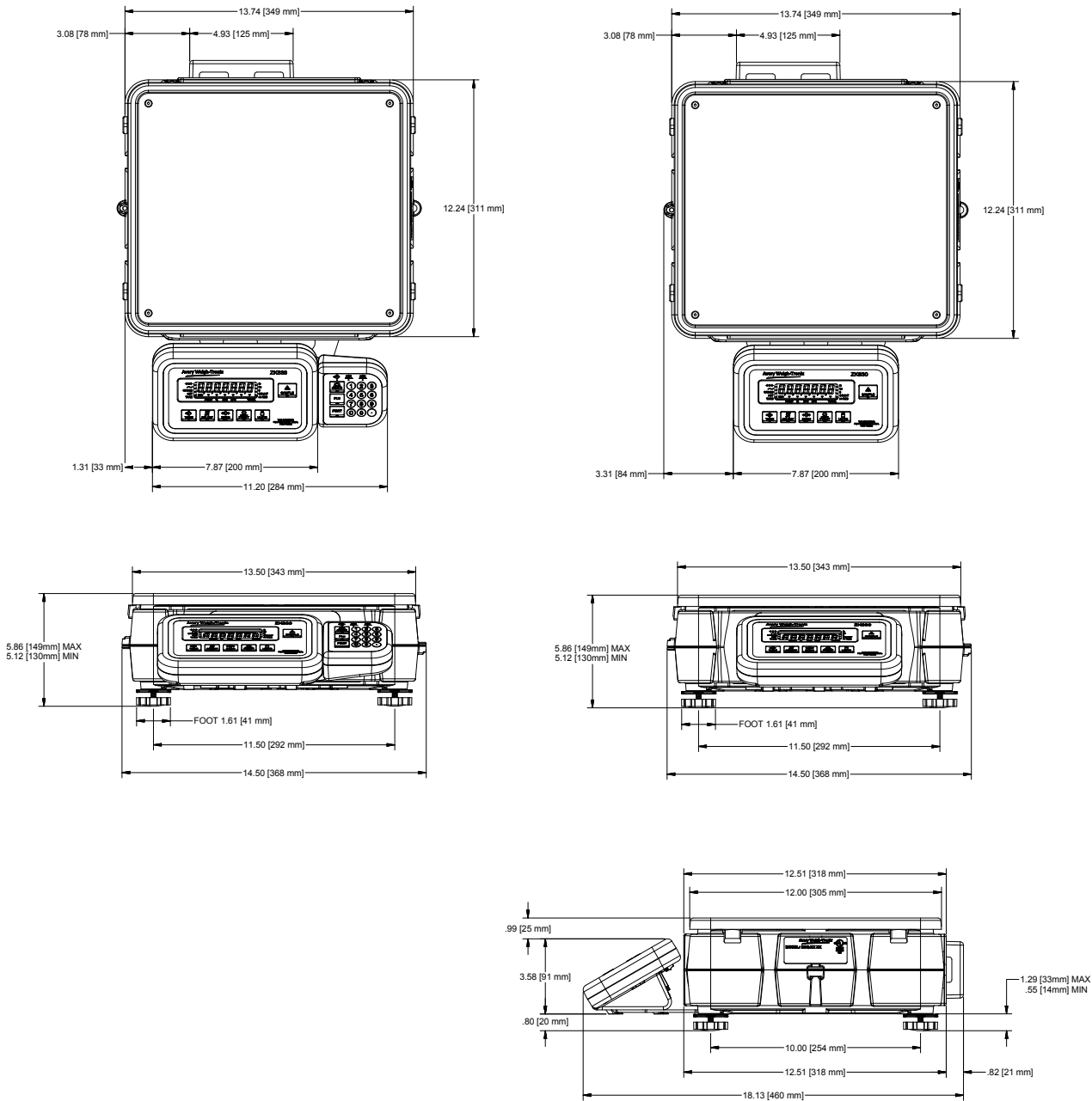

Avery Weigh-Tronix

www.averyweigh-tronix.com

Avery Weigh-Tronix is an ITW company



Avery Weigh-Tronix is a trademark of the Illinois Tool Works group of companies whose ultimate parent company is Illinois Tool Works Inc ("Illinois Tool Works"). Copyright © 2017 Illinois Tool Works. All rights reserved. This publication is issued to provide outline information only and may not be regarded as a representation relating to the products or services concerned. This publication was correct at the time of going to print, however Avery Weigh-Tronix reserves the right to alter without notice the specification, design, price or conditions of supply of any product or service at any time.