

High performance digital  
load cell

*Technical Specification*

## DESCRIPTION

High accuracy fully stainless digital compression load cell designed to be fully hermetically sealed with lightning protection to survive the world's most extreme operating conditions.

Factory calibrated to provide outstanding digital performance which is proportional to the applied load.

- Compact design
- Built to last - robust design
- Quality assured
- IP69K ideal for harsh environments
- Built-in lightning protection
- Accuracy 6000d as standard
- 100% stainless steel construction
- RS485 Communication
- Continuous self-diagnostics
- Factory calibrated digital precision
- Minimum installation required
- Immune to electrical interference
- 25 metre cable length standard

### Available capacities:

- 30 tonnes
- 45 tonnes

## FEATURES AND BENEFITS

**Pre-greased top and bottom load buttons** – Supplied as standard to help protect the load cell from harsh environments and reduce load cell rotation.

**Direct replacement for T301** – A retrofit adaptor block, designed to take up the gap between the base location and the bottom of the canister load cell, enables direct replacement. OIML R60 – Approved to 6000d, with a capacity of 30 or 45 tonnes.

**Protection against lightning damage** – Eight specially positioned surge suppressors provide a two level high voltage protection barrier built within each load cell, to help provide outstanding protection.

**Sealed to IP69K** – Suitable for use in harsh environments where flooding or harsh cleaning is a common occurrence. The T301X cable is hermetically sealed and protected from the environment with a factory sealed IP69K cable entry that eliminates all known connector problems.

**Cabling** – Fitted with a 25 metre cable that has an electrically, mechanically and chemically tough polyurethane sheathed cable for extra added protection. The T301X digitizes the signal within the load cell which allows a controlled stable digital signal (5 Volts) to travel up to 1 kilometre.

**Digital and pre-calibrated** – Making installation, cornering and calibration a fast and simple process. The T301X uses the very latest state of the art 20 bit processor that has in excess of six million internal counts to quickly and accurately convert the analogue signal into a calibrated digital signal inside the load cell casing.

**Compact design** – Developed to work within the industry standard height of 200mm, compared to the previous generation of T301. This new compact design now allows more service and installation options than ever before.

### Industry Applications and Calibration

The T301X digital canister load cell is used in a wide variety of applications around the world, from weighbridge and rail through to bin, hopper and tank weighing. Each digital load cell is accurately calibrated and tested at our factory, making it extremely fast and simple to install and service, even in hard-to-reach areas.

## SPECIFICATIONS

### General

**Load Cell Type:** Column Compression, Digital Weight Sensor  
**Rated Capacities (R.C.):** 30 t, 45 t  
**Sensitivity at Rated Capacity:** 6,000,000 d  
**Communication:** RS485 Encrypted  
**Asset Management:** Serial Number traceable

### Weighing Performance

**Cable Length, Home Run (maximum):** ≤300 m  
**Warm-up Time from Cold Start:** 5 minutes  
**Temperature Range - Compensated:** -10° to +40° C  
**Temperature Range - Operating:** -50° to +85° C  
**Temperature Range - Safe Storage:** -50° to +85° C  
**Maximum working angle:** ±3° from vertical

### Metrological Approvals

OMIL: R60 2000-GB1-11.05

Capacity	30 t	45 t
Class	Class 6	Class 6
nmax	6000	6000
Vmin	3.2	4.8

**Temp range:** -10° to +40° C

**pLC:** 0.8

**Minimum Dead Load:** 0 kg

**Metrology, Combined Error:** <150 ppm R.C.

**Temperature Effect on:**

Span (ppm R.C./deg C): <± 6

Creep at R.C. 10s to 30m (ppm R.C.): <± 120

Return to zero (ppm R.C.): <± 80

**Non-repeatability:** <±50 ppm R.C.

**Zero Balance:** <±0.1 % R.C.

### Electrical

**Supply Voltage Regulated in the load cell, Min.Max:** <±7.5 to 12max VDC

**Supply Voltage Regulated in the load cell, Typical:** <±7.5 to 12max VDC

**Lightning Protection:** Conforms to EN6-1000-4-5 2006

**Transient Voltage Surge Suppression (TVSS):** Integral (All lines)

**Insulation Resistance (strain gauge circuit):** ≥5000 MΩ @ 50VDC

**Breakdown Voltage:** ≥500 VAC

### Material

**Spring Element:** 17-4/15-5 PH Stainless Steel (magnetic)

**Enclosure:** 304 Stainless Steel

**Load Buttons:** EN24 hardened steel

**Anti-Rotation:** Industry leading sealed design

**Cable Entry Fittings:** Hermetic TIG to IP69k

**Cable:** Integral 25m x 7.5mm high environmentally resistant cable

**Connectors:** One off Flying lead glanded entry + glass-to-metal seal

### Protection

**Type:** Hermetic (submersible)

**IP Rating:** IP68 (1m - 7 days submersion), IP69K Externally Tested

**Load Limit:**

Safe: 150 % R.C.

Ultimate: 230 % R.C.

**Direction of Loading:** Compression

**Shipping Weight, nominal:**

30t Capacity: 6.8 kg (Inc: Load buttons , cable & packing)

45t Capacity: 7.8 kg (Inc: Load buttons , cable & packing)

## DIMENSIONS

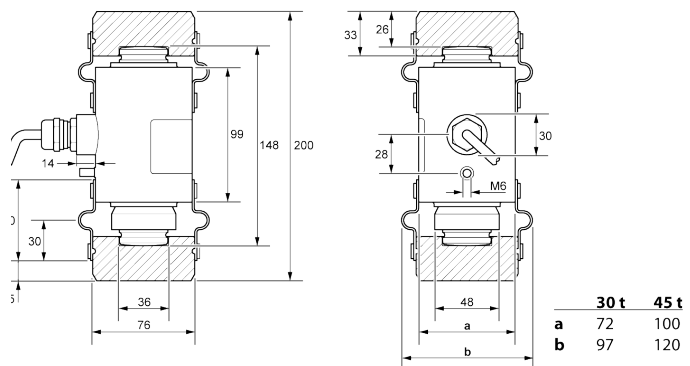

# Avery Weigh-Tronix

[www.averyweigh-tronix.com](http://www.averyweigh-tronix.com)

*Avery Weigh-Tronix is an ITW company*

