

## Avery Weigh-Tronix

Seamlessly integrate weighing and data management into your operation.



# Forklift Scales



# Simplify Your Processes

*Fast, seamless weighing,  
without any extra steps*

**Avery Weigh-Tronix**



When businesses require legal-for-trade weight data to maximise profit, increase efficiencies or meet legislative requirements, they need a fast and reliable means of capturing accurate, real-time data. Avery Weigh-Tronix forklift scales allow seamless integration of weighing and data management into your operation – without adding any extra steps or route changes.

Our durable forklift scale systems include a front-mounted scale carriage with accurate Weigh Bar® electronic weight sensors and a choice of two in-cab instruments - making it possible to lift, weigh, move and record data in one simple operation.

Our range of built-in forklift scale systems enables operators to accurately weigh materials while in transit, increasing productivity by eliminating the need to travel to a floor scale and wait for access.

## Ideal for Warehouses, Freight Terminals and Recycling Centres

### Warehouses

Managing inventory and billing in material handling environments often depends upon weighing freight on arrival and before shipping. By enhancing productivity, inventory and billing accuracy, a forklift scale can save thousands per year.

### Freight Terminals

Weight is vital to determining fees for transporting freight and properly distributing loads to avoid overload fines and unsafe conditions. Our Forklift Scale Systems

are rugged and responsive for the fast-paced terminal environment, with powerful data capture capabilities for corporate networks.

### Recycling Centres

Bundled and palletised recycling materials and waste can be weighed en route, without the driver diverting to a floor scale. This dramatically improves efficiency. The in-cab instrument's wireless option can transfer accurate weight data in real time to a back-office collection system.

## SYSTEM OVERVIEW

### FLI 225

- › Quick Interface
- › Compact Size
- › Simple to Use



### FLI 425

- › Touchscreen
- › Flexible Integration
- › Easy Connectivity



### FLSC

- › ITA Class II
- › Legal-For-Trade
- › Robust & Accurate

### QTLTSC

- › ITA Class III
- › Legal-For-Trade
- › High Capacities





## SCALE CARRIAGES

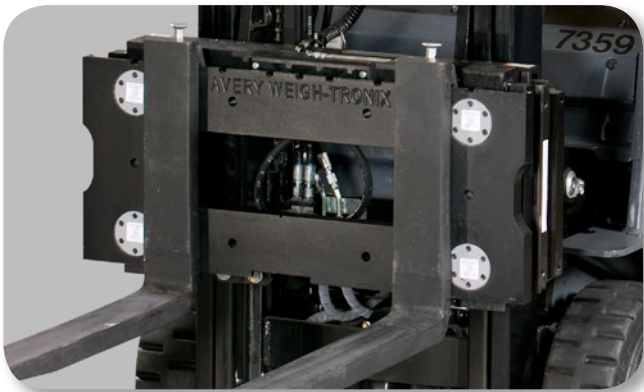

### FLSC

The FLSC digital forklift scale is a market leading system which turns an ordinary class II forklift truck into a mobile scale. This advanced digital scale comes pre-calibrated from the factory ready for a quick installation. It is built specifically for industrial/commercial applications and incorporates design features to weigh accurately under all conditions.

The FLSC is legal-for-trade, making it suitable for use in applications where product is sold by weight. The scale carriage features a completely open centre area, allowing the forklift operator to clearly see the fork tips (below).

- › ITA Class II Cleat Type carriages: 2,500kg x 2kg



### QLTSC Scale Carriage

The QLTSC is an ideal solution for applications that require a forklift scale system for a Class III cleat type forklift truck. This robust system allows operators to easily and quickly capture weight data.

- › ITA Class III Cleat Type carriages: 2,500kg x 2kg - 5,000kg x 10kg

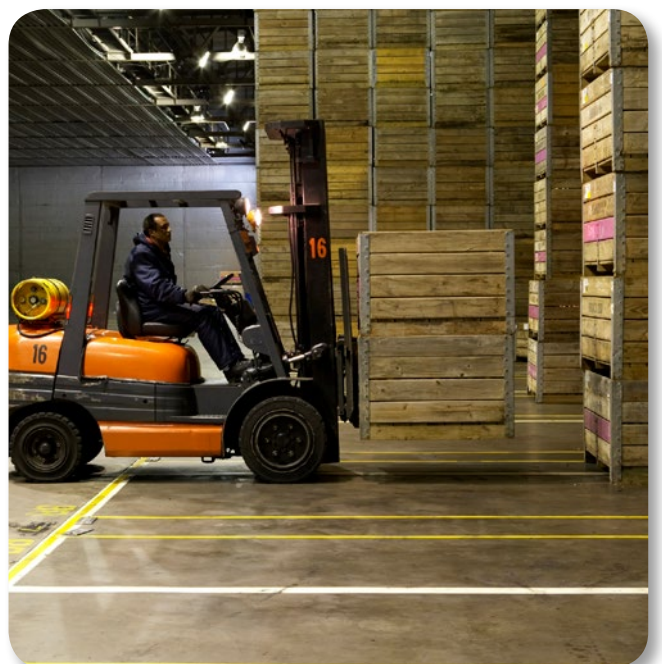

## SCALE CARRIAGE DESIGN

### Durable & Accurate

Our scale design features two metal plates coupled together by application-designed Avery Weigh-Tronix Weigh Bar weight sensors, using no flexures or springs.

The Weigh Bars electronically measure the load on the forks and convey this information to embedded summing and angle detection electronics. Compiled information is then passed on to the in-cab indicator via a cable or optional wireless connection.

The entire carriage assembly is primed and finished with a high grade powder paint.

#### Off-Axis Load Compensation

Four Weigh Bars are configured to provide accurate weighments under virtually any conditions, even if the truck is on uneven ground, the mast is tilted, or the pallet load is off-centre.

#### Easy Installation

The scale is attached to the existing forklift carriage and uses the forklift's stock forks. If needed, the scale and instrument system can be moved to another truck in minutes.

Scale Carriage Exploded View  
(FLSC shown)

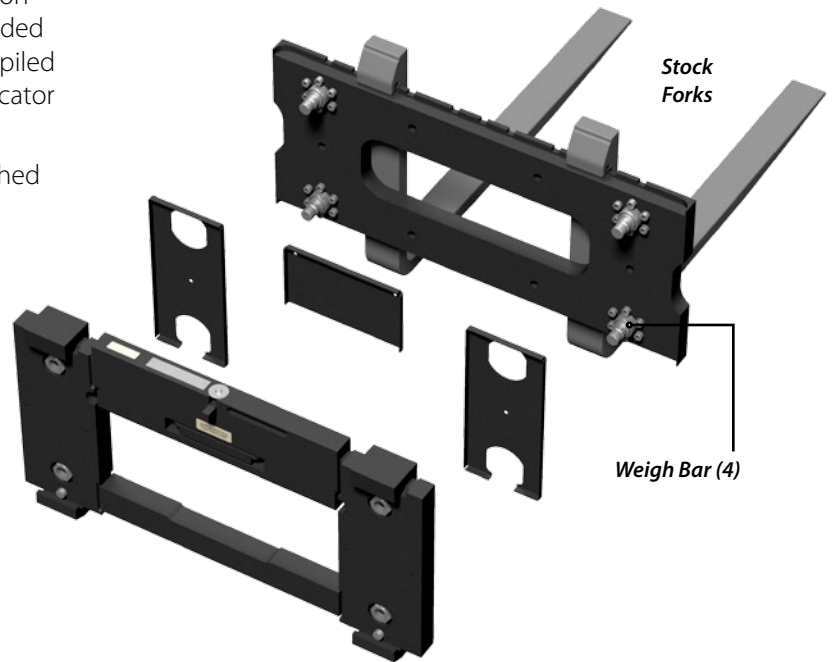

## Weigh Bar® Weight Sensors

The Weigh Bar steel structure acts as a cantilever, unsuspended on one end and fixed on the other. A load is applied to the unsuspended end. The four sensors attached to the outside of the Weigh Bar detect strain in the bar. This strain is interpreted by indicator electronics to display a weight.

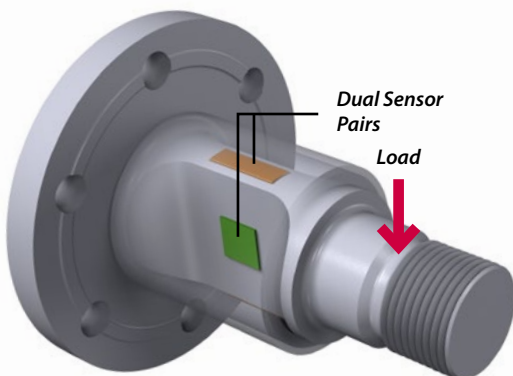

## Wireless Scale Carriage Option

Perfect for triple-mast forklifts and stock pickers or environments where the standard coiled scale instrument cable may be easily damaged (FLSC only).

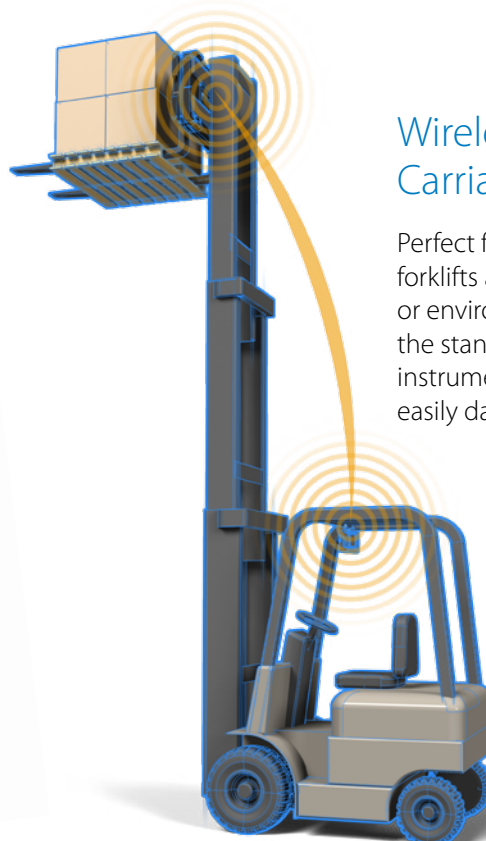

## INSTRUMENTS

### FLI 425

The FLI 425 instrument was designed exclusively for the forklift scale, providing an easy to use yet powerful way of accessing valuable scale data.

#### 178 mm Touchscreen TFT Color LCD Display

The FLI425 is capable of displaying up to 19 different data fields simultaneously, each of which can be accessed via the touchscreen. The intuitive screen also displays operator "pop-ups", wireless status, on-demand diagnostics, alpha-numeric entry, stored records and metrological details.

#### 4 Hard Keys

Common keys, including Power, F1, Store and Zero, are placed along the edge of the display, making them quickly accessible for ease of use and fast operator training.

#### IT Infrastructure Ready

Supports multiple communication protocols to allow integration into back office servers and external devices such as static dimensioners.

#### Cushioned Case Surround

The FLI 425 features a foam rubber surround, preventing injuries from accidental head contact.

#### Connectivity:

##### Standard



Ethernet USB Serial (2)

##### Optional



Wi-Fi Bluetooth



#### More Features:

- › File Transfer Protocol (FTP) ready
- › Transactions stored in memory
- › Automatic standby mode if left unattended
- › Calibration validation
- › Diagnostics Manager
  - Scale carriage
  - Audit trail
  - Overload/Underload events
  - Wireless communications
  - Many more
- › Wireless scale carriage option (FLSC only)

### FLI 225

The FLI 225 was designed for forklift scale users with simpler needs.

#### Fast View LCD Display

19 mm high weight digits for great readability. Also displays multiple lines of other data. Crisp in bright conditions and backlit for dim areas.

#### 9 Hard Keys

Limited number of keys simplifies use and minimises operator error.



#### Connectivity:

##### Standard



Serial (2)

##### Optional



Wi-Fi Bluetooth

#### More Features:

- › Classic/Expanded operation modes
- › Automatic standby feature
- › 350 transaction memory
- › Transaction/Accumulator reports
- › Instrument diagnostics mode
- › Scale diagnostics mode
- › Wireless scale carriage option (FLSC only)



**WIRELESS COMMUNICATIONS**

**Ideal for Global Networks**

As a key validation component for daily operations, the data can be used locally and/or transferred via WAN to a central server or data centre. Information is available for use by account management to create an invoice, or inventory management for validation of inbound/outbound goods and stock management. Information communicated can include:

- › Weight
- › Pro Number (ID)
- › Estimated Weight Dimensions
- › Estimated Pieces
- › Actual Pieces
- › Time/date of transaction
- › Employee ID
- › Site Location
- › Forklift ID
- › Calibration Verification
- › Dimensions

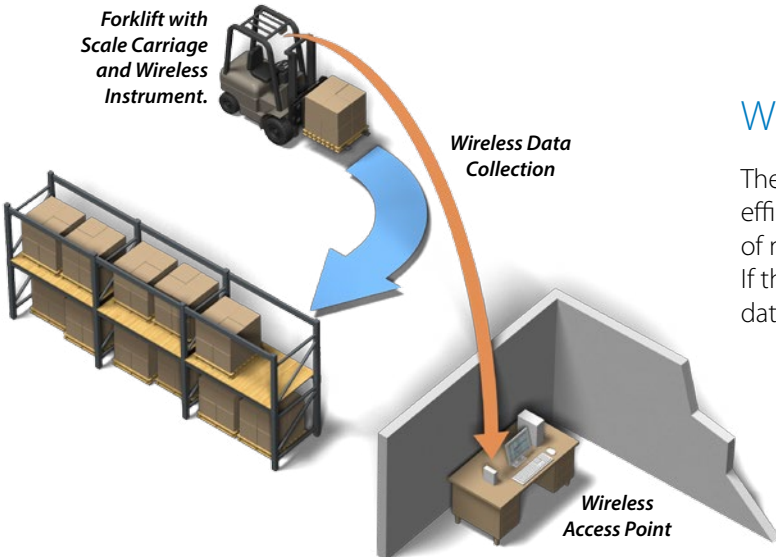
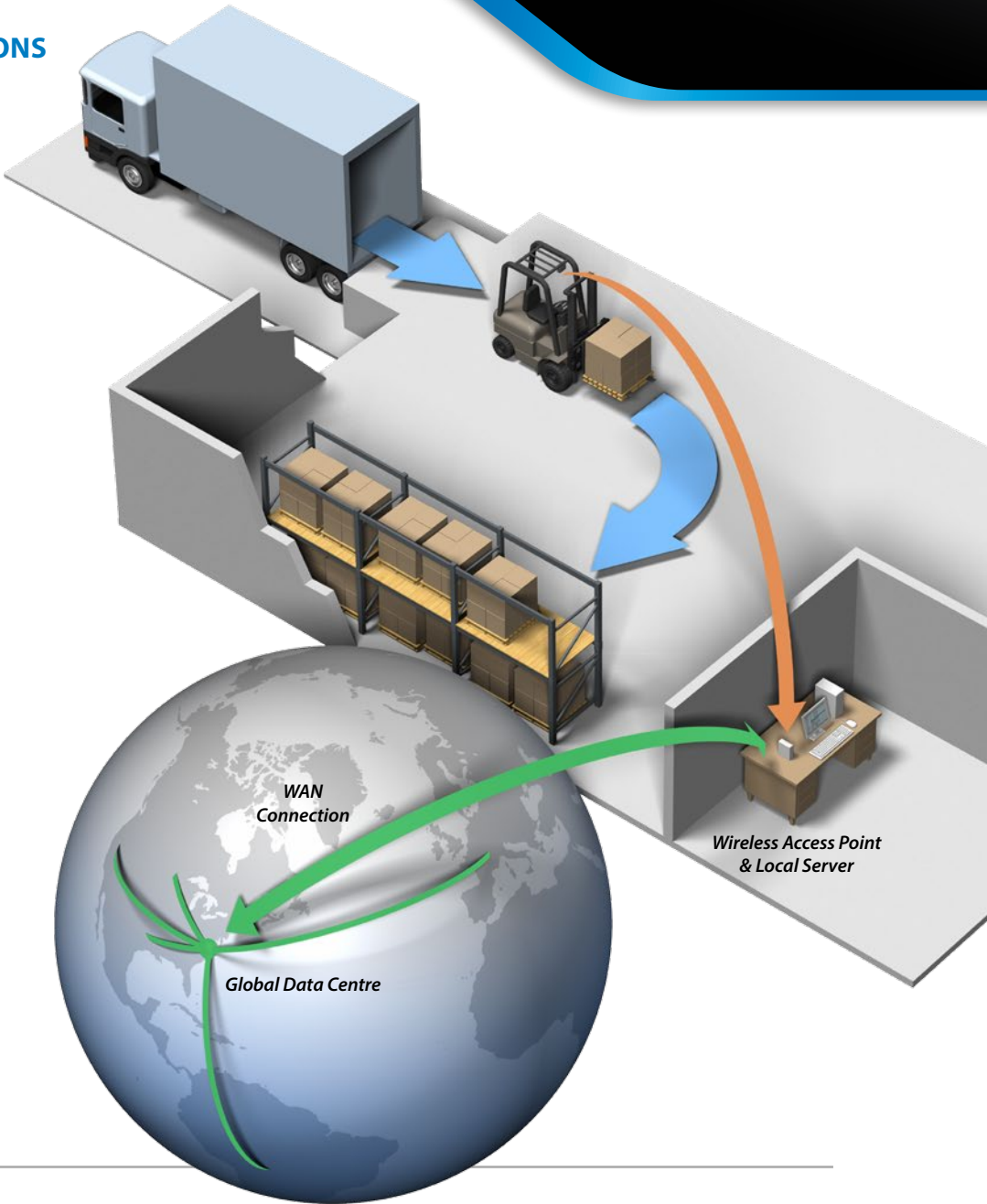

**Wireless Instrument Option**

The instrument wireless transmitter option improves efficiency. Real-time communication removes the step of manually downloading data via a wired connection. If the wireless link is lost, the instrument will save all data until the link is re-established.

OPTIONS



**1 Power Conditioner**

Regulates the power from the forklift's electrical system to the forklift scale system.

**2 Scanners**

We offer a range of scanners to fit the needs of any application.

**3 Wireless Networking**

Enables the instrument to send data to a back end software application.

**4 Bluetooth**

Interface with existing onboard computers or tablets.

**5 Removable Storage**

Choose from Compact Flash memory card or USB thumb drive to transfer stored transactions on the FLI-425 instrument to back office systems.

**6 Printers**

We offer a range of printers to meet the needs of your application.



More online

[www.averyweigh-tronix.com](http://www.averyweigh-tronix.com)

› Product literature & specifications

**Avery Weigh-Tronix**

[www.averyweigh-tronix.com](http://www.averyweigh-tronix.com)

*Avery Weigh-Tronix is an ITW company*



Avery Weigh-Tronix is a trademark of the Illinois Tool Works group of companies whose ultimate parent company is Illinois Tool Works Inc ("Illinois Tool Works"). Copyright © 2016 Illinois Tool Works. All rights reserved. This publication is issued to provide outline information only and may not be regarded as a representation relating to the products or services concerned. This publication was correct at the time of going to print, however Avery Weigh-Tronix reserves the right to alter without notice the specification, design, price or conditions of supply of any product or service at any time.

Forklift\_Scales\_L\_UK\_500390.indd  
V5 AWT500390